

On-Site Leaching Chamber Specifications & Features

Design & Installation Manual – North Carolina

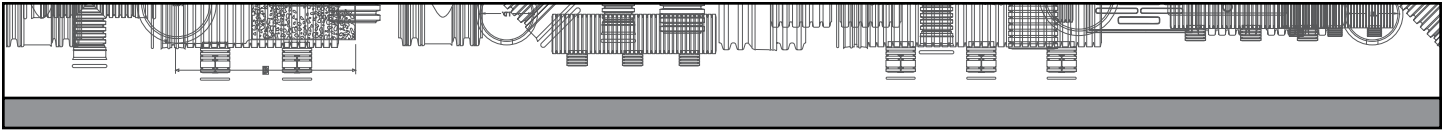

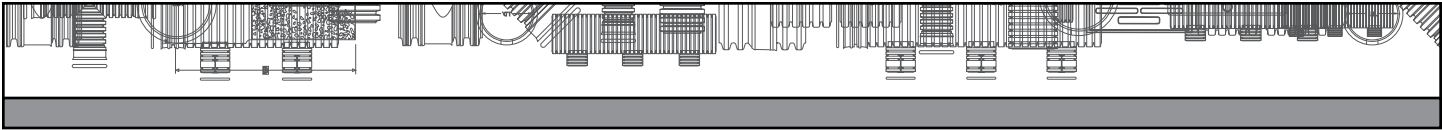



- This manual provides general design and installation information for Arc/BioDiffuser Leaching Chambers.
- This manual contains a brief description for each chamber model and general design and installation procedures. For more detailed information please contact customer service at 1-800-733-0535.
- For CAD drawings, refer to our website: www.arc-chamber.com.
- **All Arc/BioDiffuser chamber configurations and installations must comply with state and local rules.**

Contents	
Introduction	2
<hr/>	
Product Specifications	
Arc 36 System	4
Arc 36 HC System	6
11" Standard System	8
Arc 24 System	10
Bio 3 System	12
<hr/>	
Installation Instructions	14-15
<hr/>	
Standard Installations	16-17
<hr/>	
Additional System Configurations	18-21
<hr/>	
Serial Configuration	18
Serial Configuration - Side Port Coupler	19
Fill System	19
Pump System - Pressure Distribution	20
Pump System - Pressure Dispersal	21
<hr/>	
System Sizing Charts	22-23

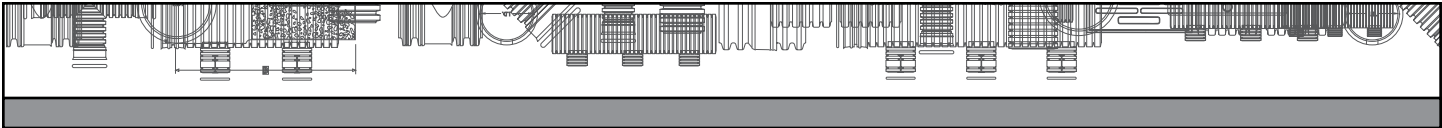

INCLUDED SYSTEMS

Arc Arc 36 System

- 34" Wide Chamber
- New Lightweight Design with Articulating Joints
- H-10 load rated with proper installation.
- *See Pages 4-5*



Arc Arc 36 HC System

- 34" Wide Chamber
- New Lightweight Design with Articulating Joints
- H-10 load rated with proper installation.
- *See Pages 6-7*



11" Standard System

- 34" Wide Chamber
- H-10 load rated with proper installation.
- *See Pages 8-9*

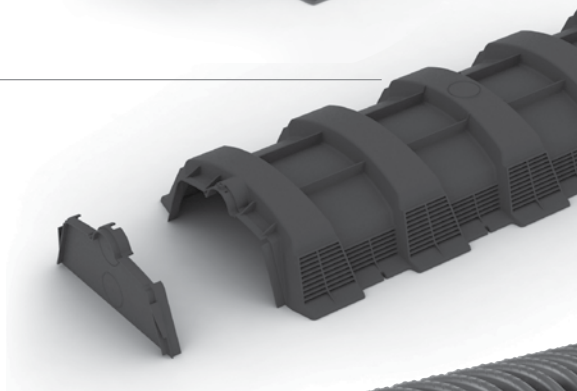

Arc Arc 24 System

- 22" Wide Chamber
- New Lightweight Design with Articulating Joints and Pivot Lockout Feature
- H-10 load rated with proper installation.
- *See Pages 10-11*

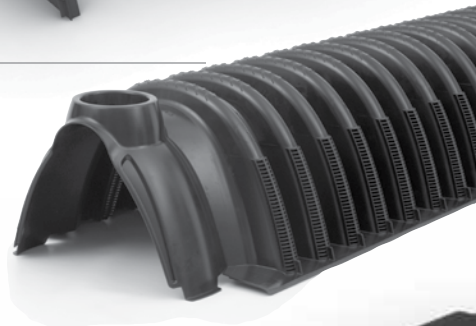

Bio 3 System

- 22" Wide Chamber
- H-10 load rated with proper installation.
- *See Pages 12-13*



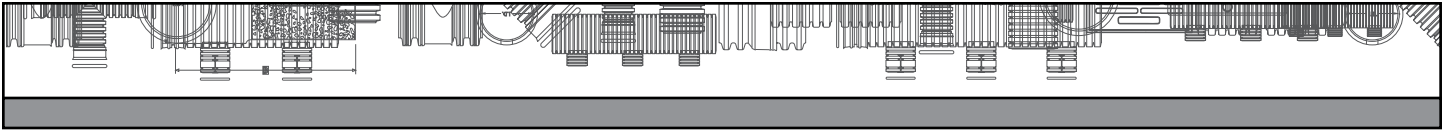

ARC 36 SYSTEM

Before beginning installation, please note the following engineered features of the Arc 36 model chambers and end caps.

Arc 36 System

- Each chamber end is either marked “Dome” or “Post” on the round observation/vent knockout ports. These indicate direction of assembly, dome over post.

Arc 36 Chamber

Length	63"
Repeat Length	60"
Overall Width	34"
Sidewall Height	7.13"
Overall Height	13"
Capacity	8.04 cu ft (60.14 gal)

Calculations and dimensions are nominal



Arc 36 Chamber—Top, Side, and End Views (not to scale)

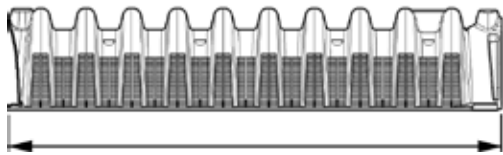
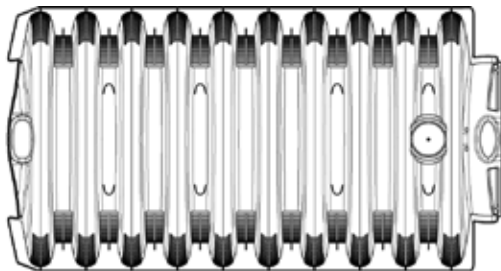

60" Effective Length

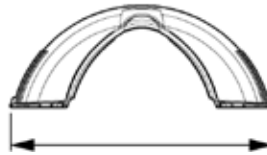

34"

Arc 36 End Cap—Side, and End Views (not to scale)

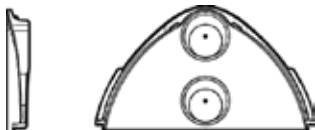

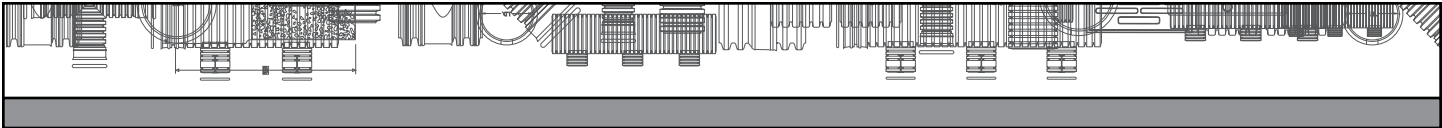

ARC 36 SYSTEM

Arc 36 Features

- The post and dome creates a positive lock securing the chambers for final engagement. Lock and drop feature for faster installation.
- The Arc 36 chamber feet are designed with an extra large surface area to provide support, particularly in sandy soils.
- Sidewall louvers are designed to allow effluent to exit the chamber sidewalls in high flow situations, while preventing soils from migrating into the chamber void.
- Observation/venting knockout ports provide for inspection of system performance as well as a convenient location for drain field ventilation pipes.
- Each chamber end has small knockouts on the roof positioned in the "Post" end joint. When removed, these knockouts allow for the use of zip ties to support piping in dosing systems.



• Lock and Drop

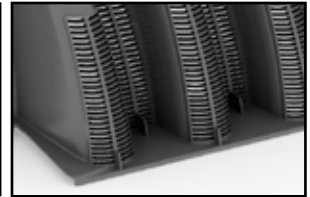

• Louvers and Feet



• Observation Port

Arc 36 Universal End Cap

- Upper and lower knockouts accommodate both Schedule 40 and SDR 35 piping. Dimples are also offered for the positioning of hole saw pilot drills.
- End caps are designed to attach to the chamber's dome or post end in the same fashion for each end with the Arc 36 logo facing outward.



Arc 36 Swivel Feature

- The engagement mechanism of the Arc 36 chamber is designed to allow for a pivot between joined chambers of up to 10° in either direction.



Arc 36 Side Port Coupler (SPC)

- SPC component snaps in place to allow side entry at any joint throughout the trench line. This accessory provides a variety of design and installation options. Refer to pages 17 for design configurations.



Arc 36 System Configurations

- Trench Installation: Page 16
- Bed Installation: Page 17
- Additional Configurations: Pages 18-21

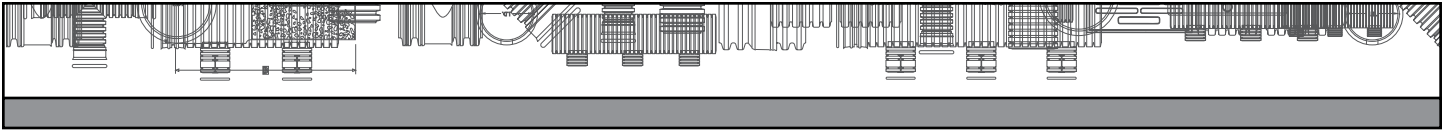

ARC 36 HC SYSTEM

Before beginning installation, please note the following engineered features of the Arc 36 HC model chambers and end caps.

Arc 36 HC System

Arc 36 HC Chamber

Length	63"
Repeat Length	60"
Overall Width	34"
Sidewall Height	7.13"
Overall Height	13"
Capacity	8.04 cu ft (60.14 gal)

Calculations and dimensions are nominal



Arc 36 HC Chamber—Top, Side, and End Views (not to scale)

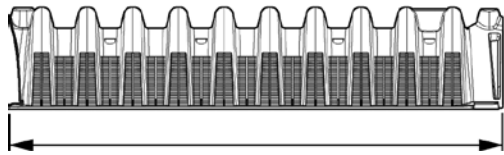
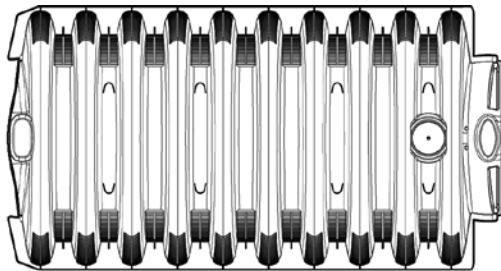

60" Effective Length

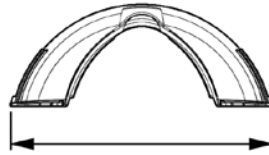

34"

Arc 36 HC End Cap—Side, and End Views (not to scale)

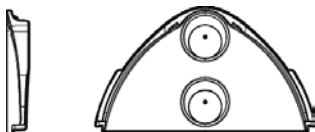

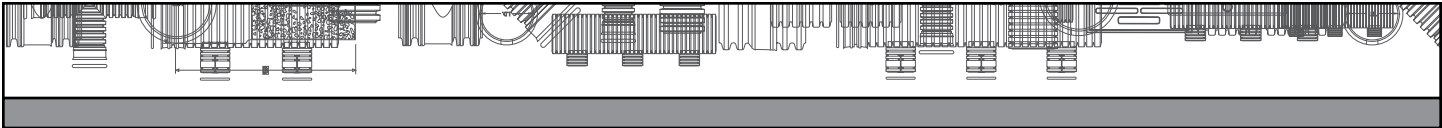

ARC 36 HC SYSTEM

Arc 36 HC Features

- The post and dome creates a positive lock securing the chambers for final engagement. Lock and drop feature for faster installation.
- The Arc 36 HC chamber feet are designed with an extra large surface area to provide support, particularly in sandy soils.
- Sidewall louvers are designed to allow effluent to exit the chamber sidewalls in high flow situations, while preventing soils from migrating into the chamber void.
- Observation/venting knockout ports provide for inspection of system performance as well as a convenient location for drain field ventilation pipes.
- Each chamber end has small knockouts on the roof positioned in the "Post" end joint. When removed, these knockouts allow for the use of zip ties to support piping in dosing systems.



• Lock and Drop



• Louvers and Feet



• Observation Port

Arc 36 HC Universal End Cap

- Upper and lower knockouts accommodate both Schedule 40 and SDR 35 piping. Knockouts can be removed with a knife or hole saw. Dimples are also offered for the positioning of hole saw pilot drills.
- End caps are designed to attach to the chamber's dome or post end in the same fashion for each end with the Arc 36 logo facing outward.



Arc 36 HC Swivel Feature

- The engagement mechanism of the Arc 36 chamber is designed to allow for a pivot between joined chambers of up to 10° in either direction.



Arc 36 HC Side Port Coupler

- Side Port Coupler component snaps in place to allow side entry at any joint throughout the trench line. This accessory provides a variety of design and installation options. Refer to pages 22 and 23 for design configurations.



Arc 36 HC System Configurations

- Trench Installation: Page 16
- Bed Installation: Page 17

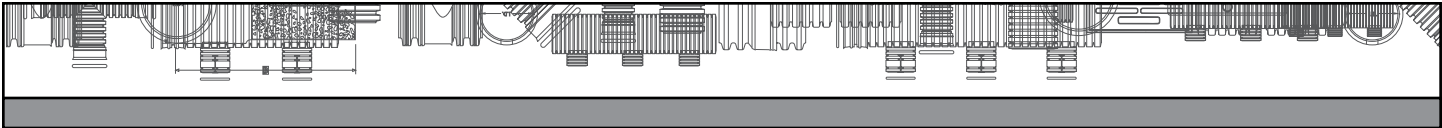

11" STANDARD SYSTEM

Before beginning installation, please note the following engineered features of the 11" Standard model chambers and end caps.

11" Standard System

- Each chamber end is either marked "Dome" or "Post" on the round observation/vent knockout ports. These indicate direction of assembly, dome over post.

11" Std Chamber

Length	76"
Repeat Length	75"
Overall Width	34"
Sidewall Height	6.35"
Overall Height	11"
Capacity	9.21 cu ft (68.42 gal)

Calculations and dimensions are nominal

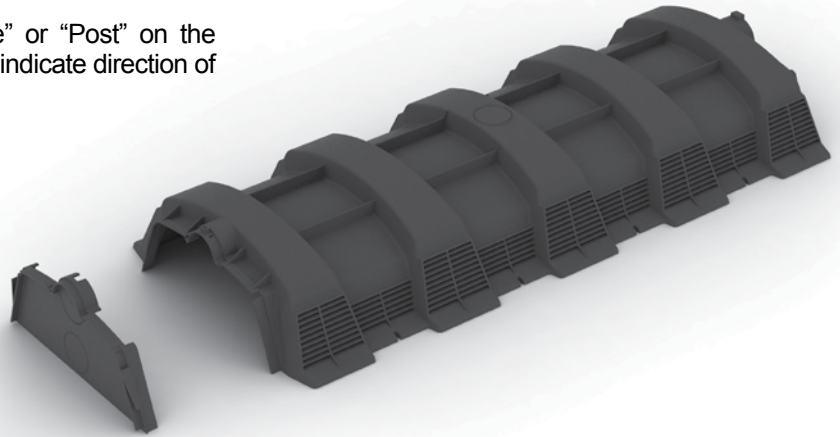

11" Standard Chamber — Top, Side, and End Views (not to scale)

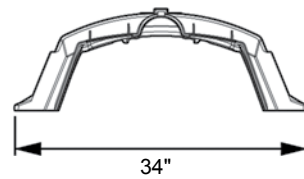
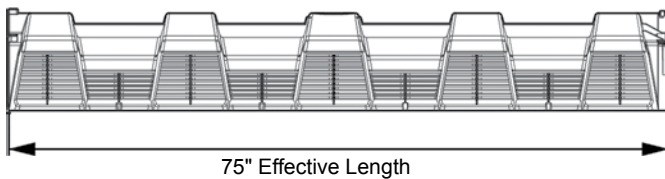
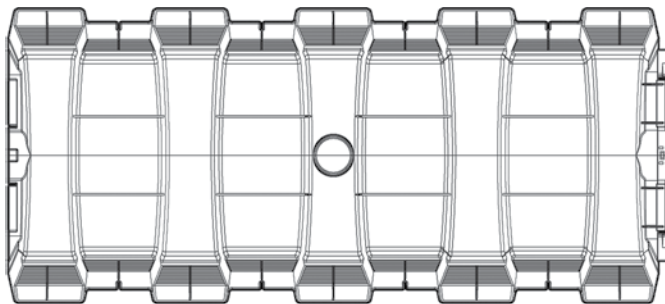

11" Standard End Cap — Side, and End Views (not to scale)

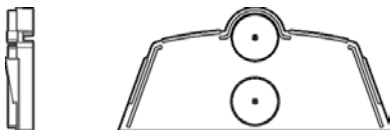

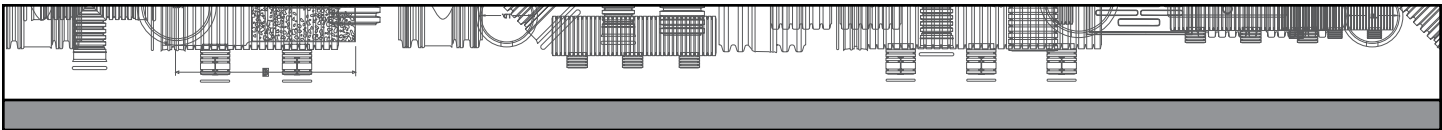

11" STANDARD SYSTEM

11" Standard Features

- The post and dome creates a positive lock securing the chambers for final engagement.
- The 11" Standard chamber feet are designed with an extra large surface area to provide support, particularly in sandy soils.
- Sidewall louvers are designed to allow effluent to exit the chamber sidewalls in high flow situations, while preventing soils from migrating into the chamber void.
- Observation/venting knockout ports provide for inspection of system performance as well as a convenient location for drain field ventilation pipes.
- Each chamber end has small knockouts on the roof positioned in the "Post" end joint. When removed, these knockouts all for the use of zip ties to support piping in dosing systems.

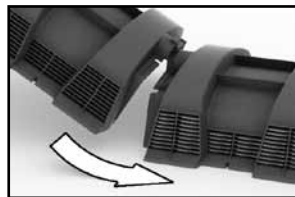

• Interlocking joint

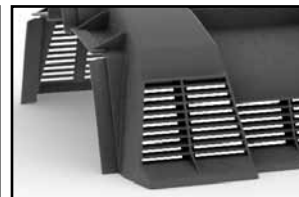

• Louvers and Feet



• Observation Port

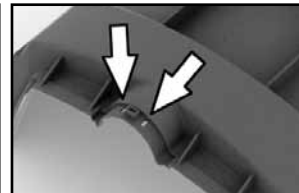

• Zip Tie Knockouts

11" Standard Universal End Cap

- Upper and lower knockouts accommodate both Schedule 40 and SDR 35 piping. Dimples are also offered for the positioning of hole saw pilot drills.
- End caps are designed to attach the chamber's dome or post end.

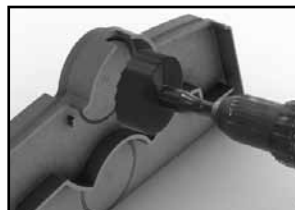

11" Standard System Configurations

- Trench Installation: Page 16
- Bed Installation: Page 17
- Additional Configurations: Pages 18-21

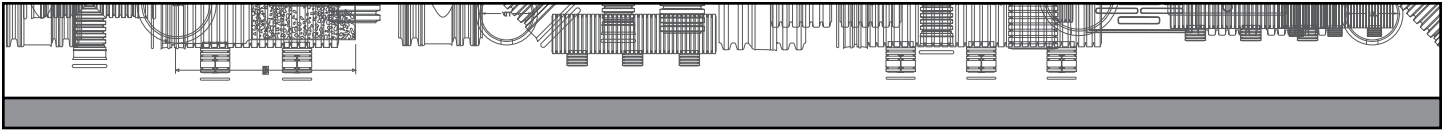

ARC 24 SYSTEM

Before beginning installation, please note the following engineered features of the Arc 24 model chambers and end caps.

Arc 24 System

- Each chamber end is either marked “Dome” or “Post” on the round observation/vent knockout ports. These indicate direction of assembly, dome over post.

Arc 24 Chamber	
Length	67"
Repeat Length	60"
Overall Width	22"
Sidewall Height	7.5"
Overall Height	12"
Capacity	5.02 cu ft (37.5 gal)

Calculations and dimensions are nominal



Arc 24 Chamber — Top, Side, and End Views (not to scale)

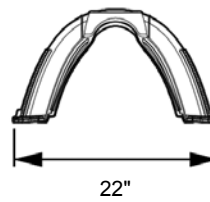
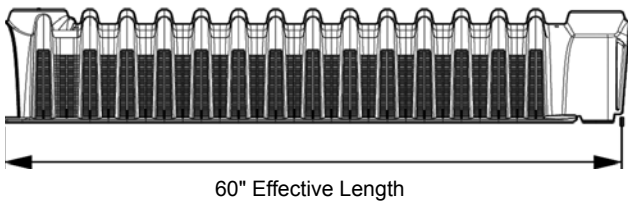
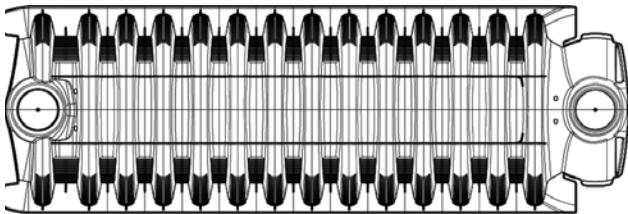

Arc 24 End Cap — Side, and End Views (not to scale)

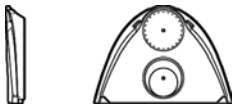

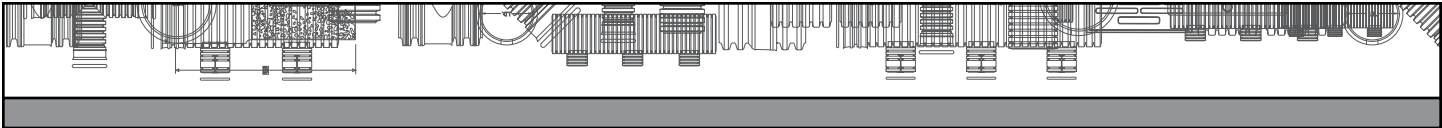

ARC 24 SYSTEM

Arc 24 Features

- Base flanges on the chambers ends over lock during final engagement to form a very strong joint.
- The Arc 24 chamber feet are designed with an extra large surface area to provide support particularly in sandy soils.
- Sidewall louvers are designed to allow effluent to exit the chamber sidewalls in high flow situations, while preventing soils from migrating into the chamber void.
- Observation/venting knockout ports provide for inspection of system performance as well as a convenient location for drain field ventilation pipes.
- Each chamber end has small knockouts on the roof positioned in the "Post" end joint. When removed, these knockouts all for the use of zip ties to support piping in dosing systems.

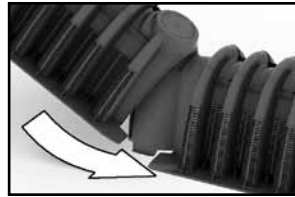

• Overlocking Ends

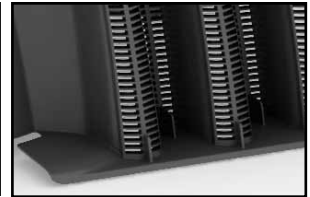

• Louvers and Feet



• Observation Port

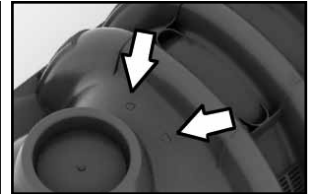

• Zip Tie Knockouts

Arc 24 End Cap

- Upper and lower knockouts accommodate both Schedule 40 and SDR 35 piping. Dimples are also offered for the positioning of hole saw pilot drills.
- End caps are designed to attach the chamber's dome or post end.

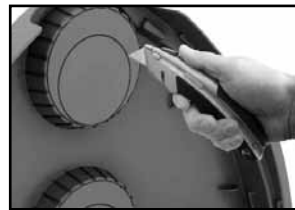

Arc 24 Swivel Feature

- Each chamber's post end has swivel lockout tabs at either base flange. When removed, the incoming chamber will turn up to ten degrees in the direction of the removed lockout tab. Without removal of the swivel lockout tab, the chambers will align in a straight pattern.
- Swivel lockout tabs may be removed with a striking blow to the tab and then peeling off the remaining piece of plastic.

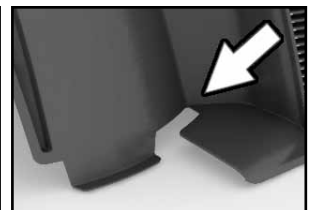
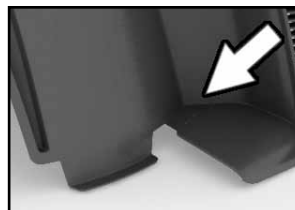

Arc 24 Side Port Coupler (SPC)

- SPC component snaps in place to allow side entry at any joint throughout the trench line. This accessory provides a variety of design and installation options. Refer to page 17 for design configurations.



Arc 24 System Configurations

- Trench Installation: Page 16
- Bed Installation: Page 17
- Additional Configurations: Pages 18-21

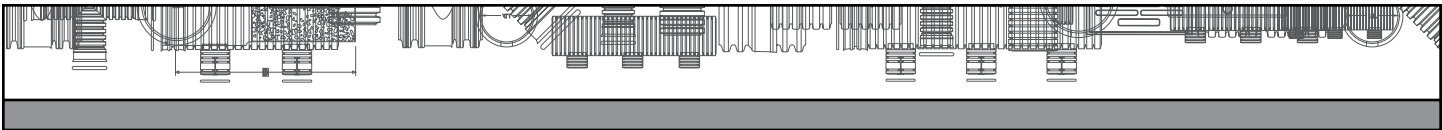

BIO 3 SYSTEM

Before beginning installation, please note the following engineered features of the Bio 3 model chambers and end caps.

Bio 3 System

- Each chamber end is either marked “Dome” or “Post” on the round observation/vent knockout ports. These indicate direction of assembly, dome over post.

Bio 3 Chamber	
Length	87"
Repeat Length	86"
Overall Width	22"
Sidewall Height	9.03"
Overall Height	12"
Capacity	8.5 cu ft (62.8 gal)



Calculations and dimensions are nominal

Bio 3 Chamber — Top, Side, and End Views (not to scale)

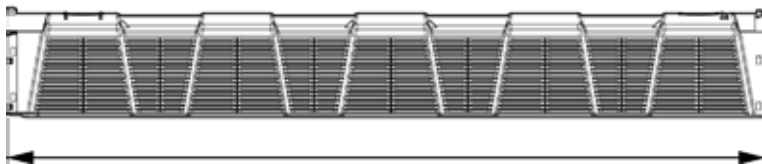
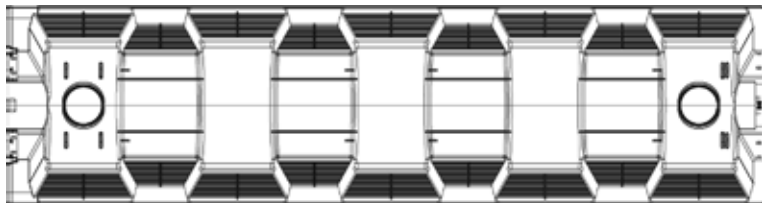

86" Effective Length

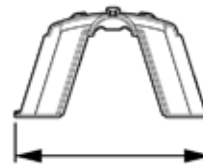

22"

Bio 3 End Cap — Side, and End Views (not to scale)

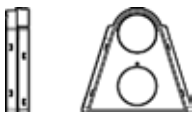

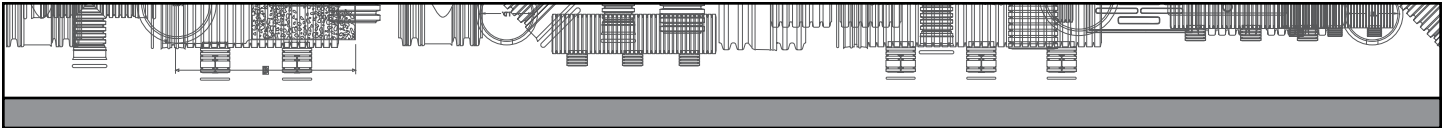

BIO 3 SYSTEMS

Bio 3 Features

- Base flanges on the chamber ends over lock during final engagement to form a very strong joint.
- The Bio 3 chamber feet are designed with an extra large surface area to provide support, particularly in sandy soils.
- Sidewall louvers are designed to allow effluent to exit the chamber sidewalls in high flow situations, while preventing soils from migrating into the chamber void.
- Observation/venting knockout ports provide for inspection of system performance as well as a convenient location for drain field ventilation pipes.
- Each chamber end has small knockouts on the roof positioned in the “Post” end joint. When removed, these knockouts allow for the use of zip ties to support piping in dosing systems.

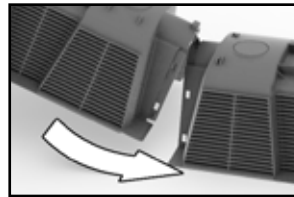

• Interlocking Joint



• Louvers and Feet

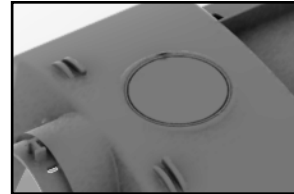

• Observation Port

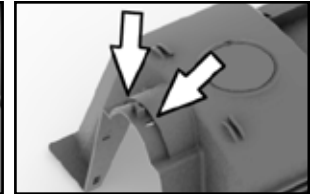

• Zip Tie Knockouts

Bio 3 Universal End Cap

- Upper and lower knockouts accommodate both Schedule 40 and SDR 35 piping. Dimples are also offered for the positioning of hole saw pilot drills.
- End caps are designed to attach the chamber's dome or post end.



Bio 3 System Configurations

- Trench Installation: Page 16
- Bed Installation: Page 17
- Additional Configurations: Pages 18-21

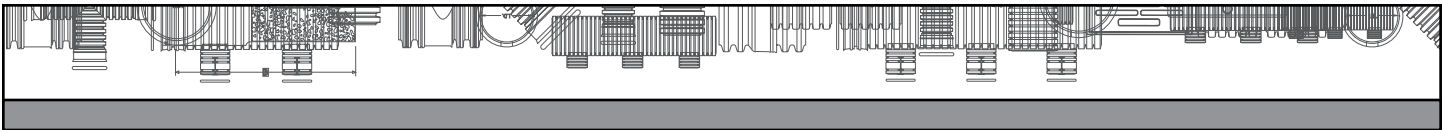

ARC/BIODIFFUSER LEACHING SYSTEMS: INSTALLATION PROCEDURES

Preparation

- Excavate to proper width and depth as described in the system plans, design and/or permit. All excavations must comply with state and local rules as well as the appropriate NC DENR system approval.
- Smooth irregularities in the excavation and clear rocks and debris from the bottom surface area. For trench installations, the bottom is recommended to be level, but no greater than one-inch of fall is allowed per 100 feet. For bed installations, the bottom shall be level and there shall be a 1-3 inch separation between chamber lines measured from the edge of the chamber.

Installation

- Installation of the any ADS/Hancor Arc/BioDiffuser leaching system begins with laying the first chamber onto the prepared bottom surface area, with the “dome” end of the chamber at the header end of the excavation. Each additional incoming chamber is then installed by placing its dome over the post of the chamber already in place.

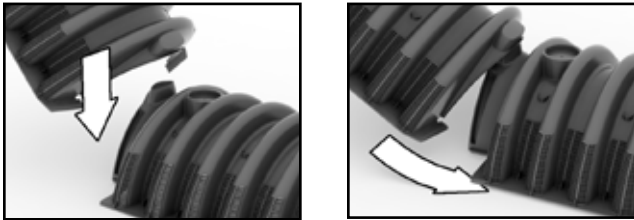

A slight tug of the chamber will “lock” the joint to the previously installed chamber. Once “lock” engagement occurs, “drop” (lower) the incoming chamber into place.

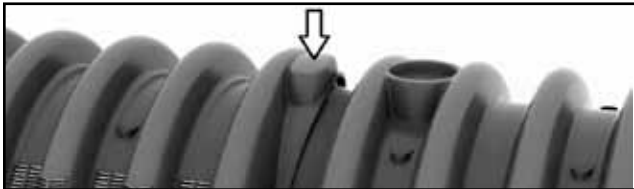

- As the incoming chamber is lowered down onto the excavation bottom, the two chambers fully engage in a straight-line pattern creating a very strong joint.

Note: if the following chamber is simply laid onto the preceding chamber the joint will not be fully engaged.

Turns

- The Arc 36 and Arc 24 chambers are designed with an articulating joint that allows for a turn of up to 20°, with maximum of 10° in either direction.



Turns (continued)

(Note: The Arc 24 is designed with lockout tabs)

- If a turn application is desired with the Arc 24 chamber, the lockout tab should be removed before installing the incoming chamber. The lockout tab is located at the base flange of the previously–installed chamber (on its “Post” end).

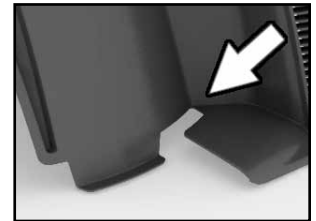
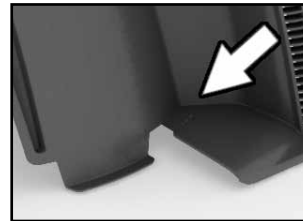

Installation of End Caps & Pipe Connections

- Prior to installing end caps, remove the appropriate knockout for pipe connections. Snap an end cap on each end of the drain lines with the product or company logo facing out (knockouts can be removed with a knife or a 4” hole saw).

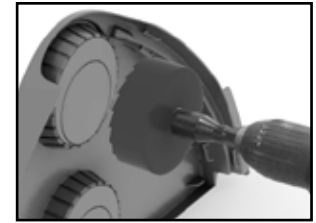

- **Upper end cap 4” knockouts — shall always be used as inlet for each line.** A four-inch hole saw may be used.
- Lower end cap 4” knockouts—may be used to create turns in the drain lines greater than the ten degrees provided by the chamber swivel feature.

Splash Plates

- Splash plates are optional on each inlet end cap for gravity delivery of effluent.
- Company-provided splash plates are installed by simply aligning the holes on the splash plate with the corresponding dimples on the end cap and snapping into place.
- Splash plates are sold separately.
- A custom “receiving area” is required on all BioDiffuser/ARC chamber systems where effluent is provided to the system under pressure (see pages 20 & 21).

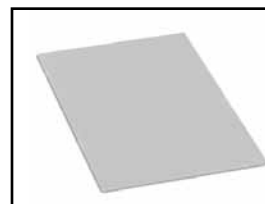

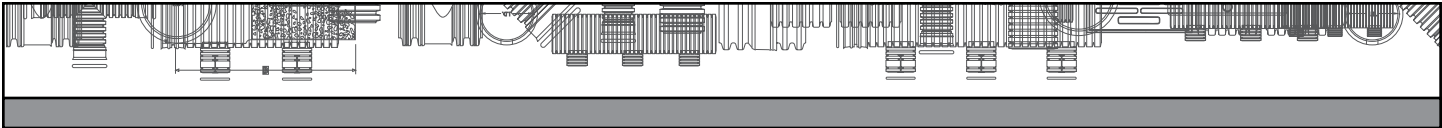

ARC/BIODIFFUSER LEACHING SYSTEMS: INSTALLATION PROCEDURES

Filter Fabric

The use of filter fabric is recommended, and may be required, in certain soil conditions. If used, drape the fabric to completely cover the louvered sidewalls of the chambers to prevent soil intrusion, while allowing water and air to pass through.

The following single or combination of conditions warrant the use of filter fabric:

- The back fill material is fine or very fine uniform sand.
- The drain field will be left uncovered.
- The drain field will not be protected from surface runoff drainage, (i.e. downspouts, barrel-tile roofs, paved areas, and neighboring property).
- The bottom of the drain field will be less than 12" from seasonal high water level.
- Filter fabric shall meet the following specifications and can be purchased from your ADS/Hancor BioDiffuser distributors:
 - Fabric: Spun bonded, made up of nylon fibers, hydrophilic in nature.
 - Weight: 0.35 – 1 oz/yd²
 - AOS: 20-30 U.S. Sieve (ASTN D4571)

Ventilation

Drain field ventilation is recommended, but not required, to allow oxygen to access the drain field especially when cover soil quality is questionable.

- Knockouts are provided on the 11" Standard, Arc 36, and Bio 3 chambers. The dome/post feature of the Arc 24 chamber also acts as a knock-out for observation/vent ports. Here a PVC pipe may be introduced into the chamber and vented to atmosphere.
- Make certain that vents are assembled in such a fashion as to prevent rainwater from entering and effluent from exiting the chamber line.
- Several outlet products are available for this purpose.

Backfilling

- After chamber assembly is completed, fill that area adjacent to the louvered sidewall with loose soil that is free from clods or rocks.

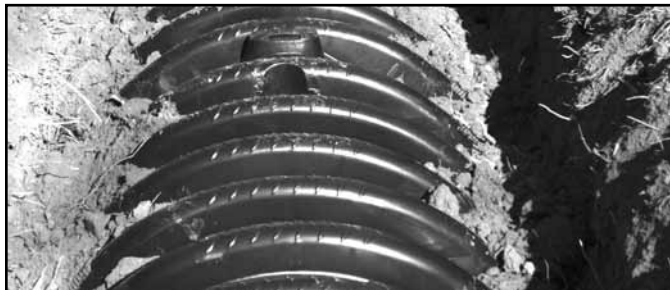

- Modestly compact the sidewall area backfill material by simply walking down the sides of the chambers. Sidewall compaction is important to begin the stabilization process of the soil, to support the chamber sidewalls, and help prevent fine sand migration into the chamber louvers. This procedure may be accomplished any time during the installation or covering process.



- All ARC chambers are H-10 load rated. Where vehicular loading is anticipated during installation of the system or construction of the facility, H-10 loading (16,000 lbs/axle) is achieved by backfilling with a minimum of 12" of properly compacted cover.
- Do not drive heavy equipment over a system comprised of non-compacted cover material without first bridging the excavation. Use lightweight or tracked equipment to push the soil onto the system to the proper height set forth by local and state codes.

Final Grade

- Make certain that storm water runoff is diverted away from the drain field. System final grade should be crested or sloped, never left flat or concave. Channel water away from the drain field.
- Final grading subcontractors and landscapers should be alerted and instructed to proper covering procedures, cover materials, and finish contours and elevations.
- Final grade material should be shaped and smoothed with minimum equipment traffic to help maintain an aerobic state in the drain field.
- Stabilize the drain field area with grass-type vegetation prior to heavy rains if possible.

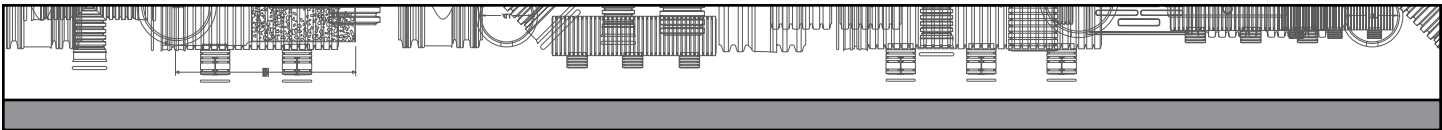

Typical Installation:

I. Trench Configuration

- The typical installation is utilized on level sites.

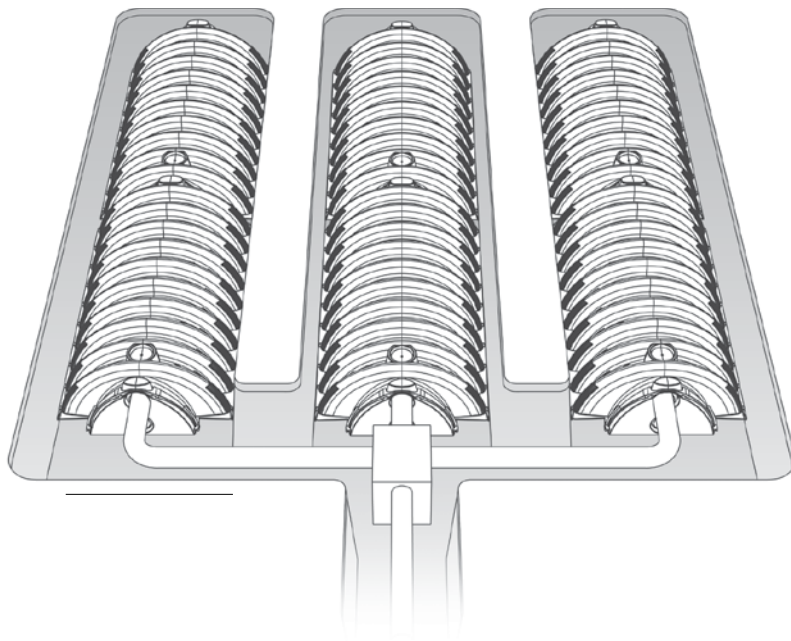

Typical Trench: Cross Section

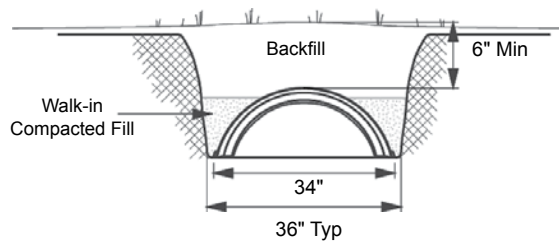

Typical Trench: Plan View

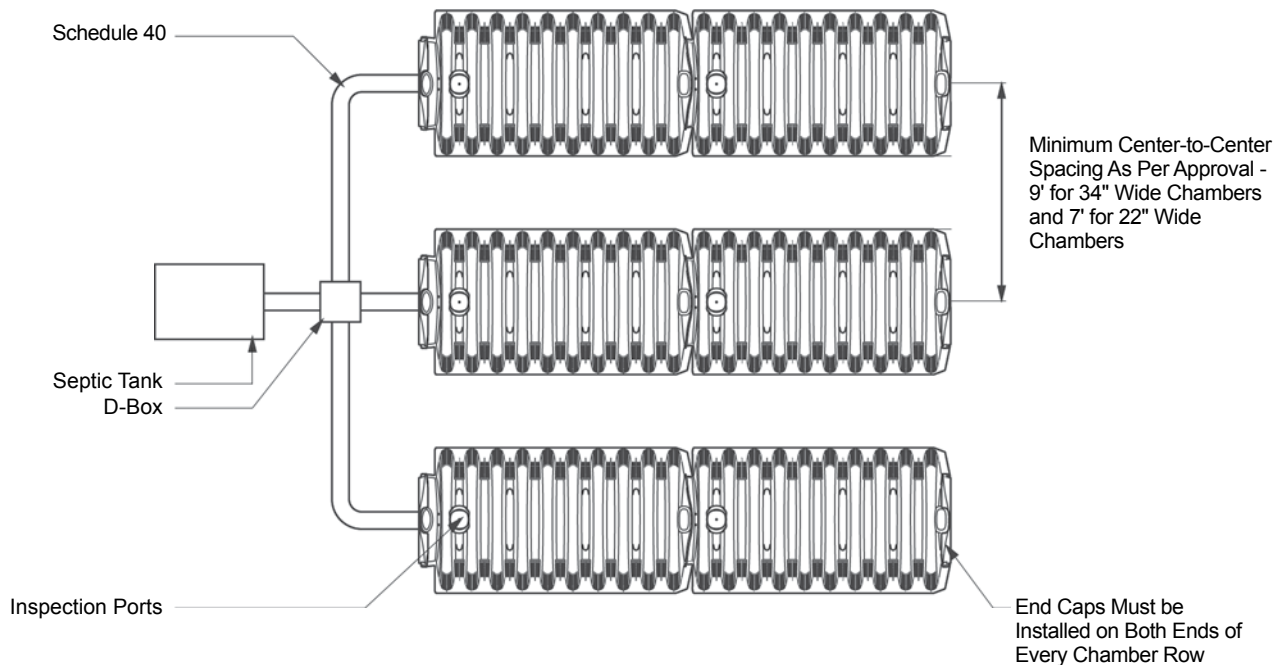

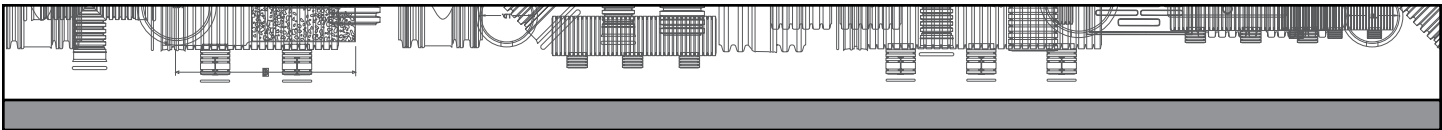

Typical Installation:

II. Bed Configuration

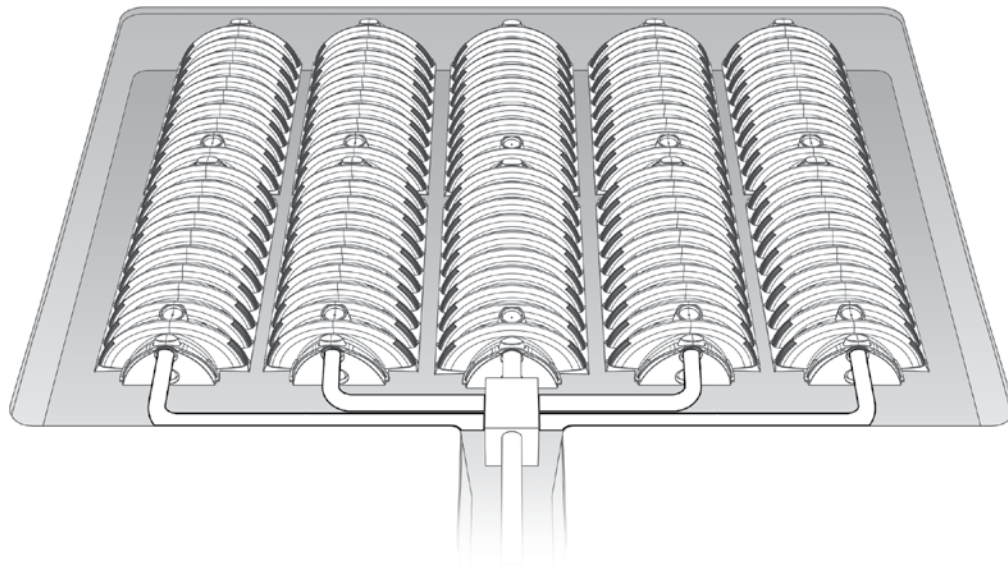

Typical Bed: Cross Section

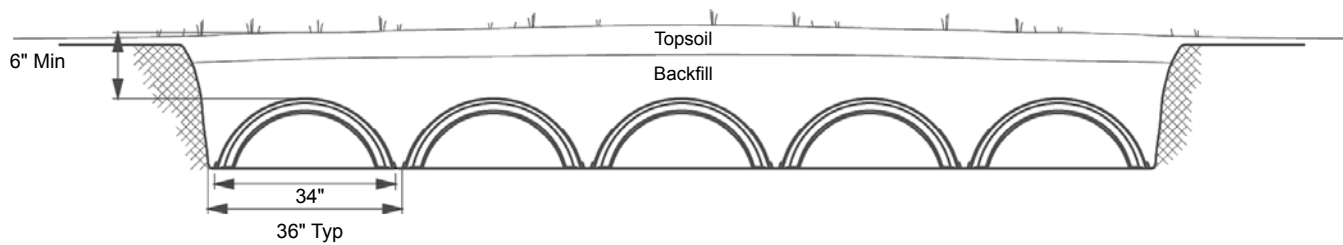

Typical Bed: Plan View

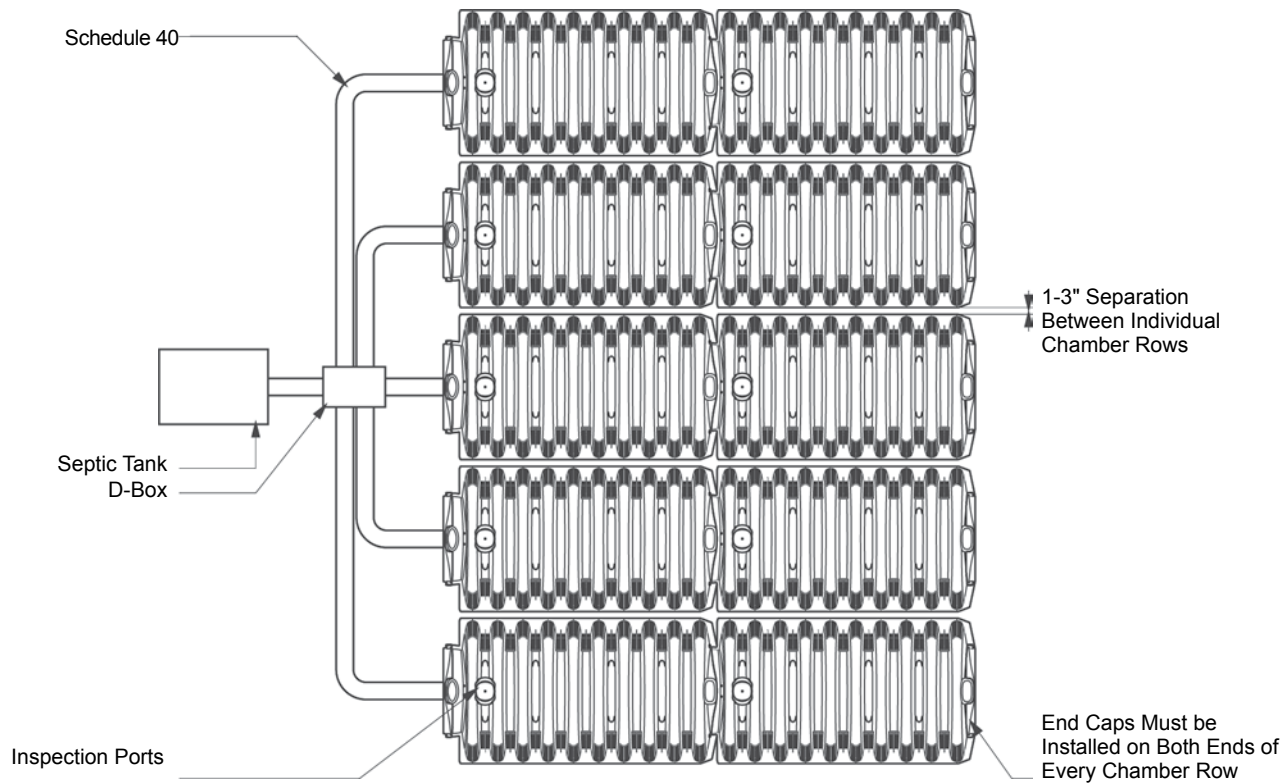

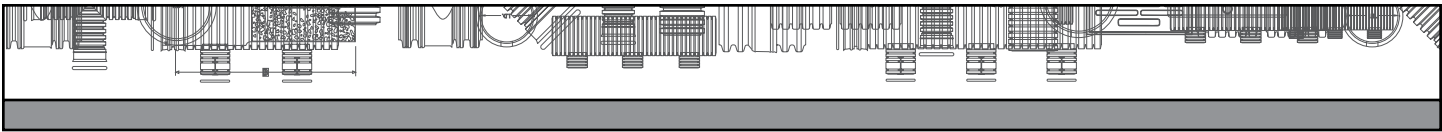

Additional Configurations:

**I. Serial Configuration
– Direct (End Cap-to-End Cap)**

- This configuration is installed on sloping or level sites.

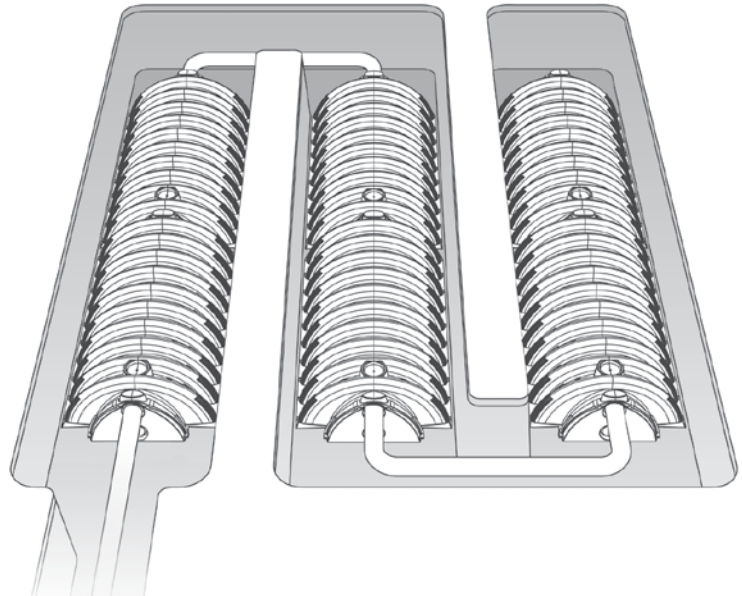

Serial to Direct: Cross Section (level)

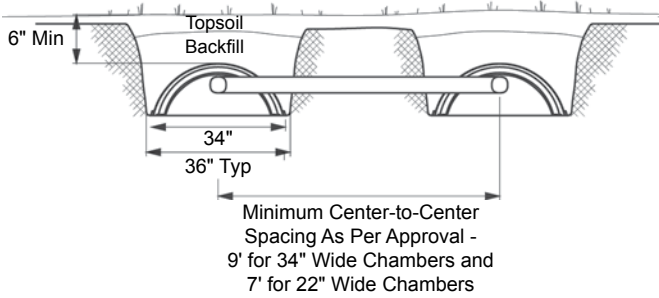

Serial to Direct: Cross Section (slope)

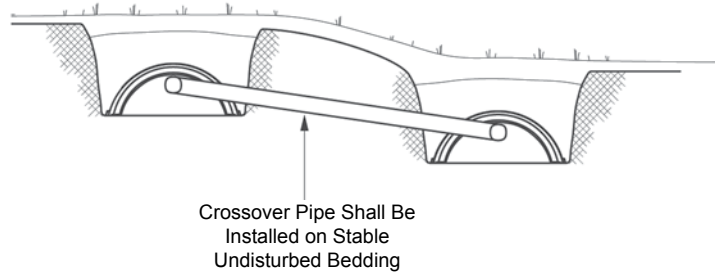

Serial to Direct: Plan View

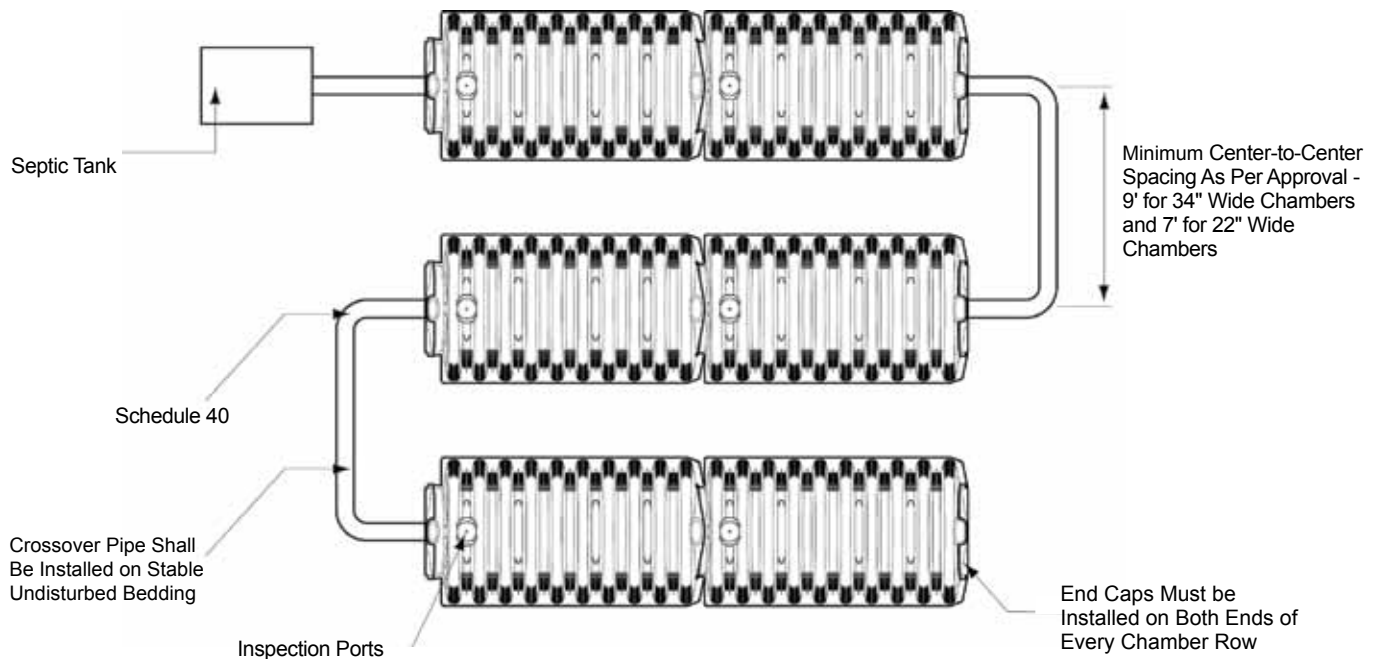

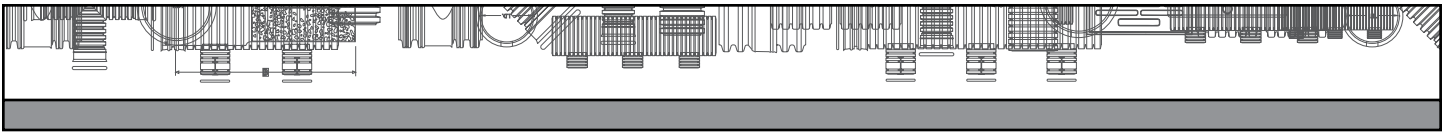

Additional Configurations:

II. Serial Configuration

– Side Port Coupler to Side Port Coupler (SPC to SPC)

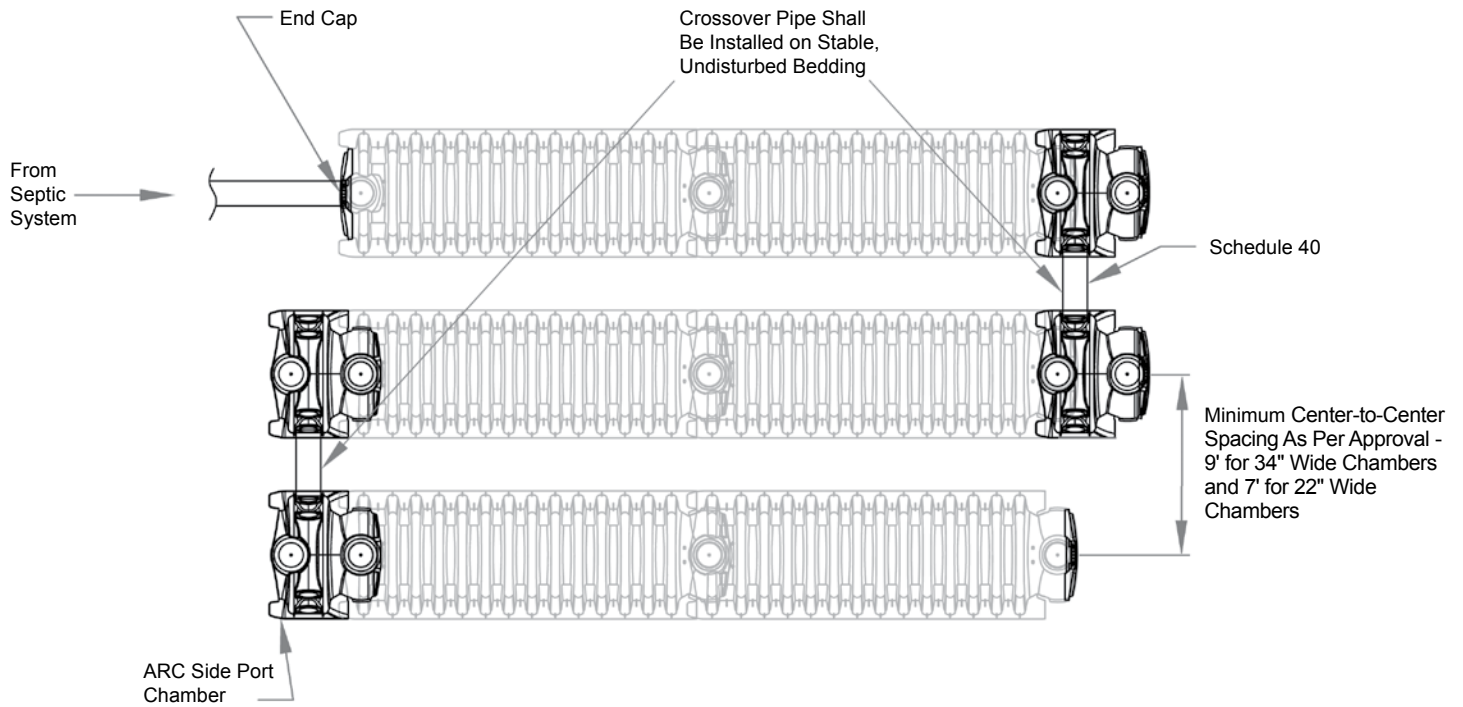

Additional Configurations:

III. Fill System

Fill System: Section View

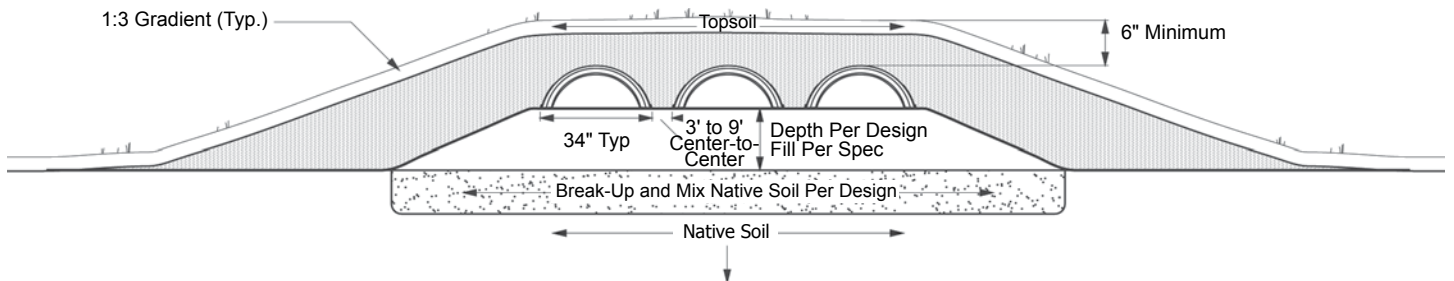

Notes:

- Fill systems typically found in the coastal plain region of NC in a Group I soil.
- The rise:run ratio depicted in the configuration above is 1:3. For Group II, III, and IV the ratio is 1:4.
- Remove layers of vegetation (i.e. grass) and properly incorporate/mix (homogeneous) suitable fill material with the natural soil surface at the interface.
- At least 6-inches of Group II and/or Group III soil cover is required to promote vegetative growth and reduce erosion.

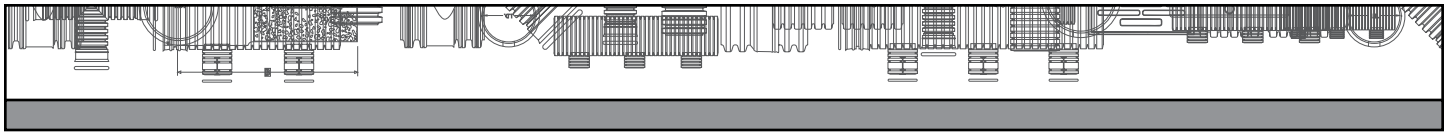

Additional Configurations:

IV. Pump Systems: Pressure Distribution

– High flow dissipation is required on all of these systems

– Approved pressure distribution device methods include pressure manifold, flow splitter and distribution box.

Pressure Distribution: Receiving Area

- This specification is required for all dosed systems.

Position PVC Inlet/Header Pipe Through Upper End Cap Knockout and Attach Elbow (90°) Fitting. Center of the Elbow Shall be Located Inside the Center of the "Receiving Area," Pointing Downward.

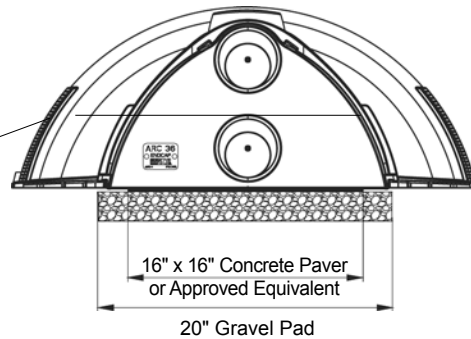

Use of 3" or Smaller PVC as Inlet Requires Use of Appropriate Hole Saw.

PRESSURE DISTRIBUTION: INSTALLATION INSTRUCTIONS FOR RECEIVING AREA, OBSERVATION PORT, AND VENT PIPE

Background

Systems utilizing pressure dosing must be inspected prior to final backfill, and vented. Because effluent entering a chamber line under pressure may disturb the biomat on the trench bottom infiltrative surface, a "receiving area" must be created to dissipate this flow. When installing a pressure dosed system, the following steps must be performed.

Side Port Coupler (SPC)

- In order to provide for an observation port directly above the receiving area, a SPC, with an end cap, must be used on the inlet end of each chamber line.

Receiving Area

- The Contractor shall prepare a "receiving area" by centering a 16" x 16" concrete paver (or an approved equivalent) over a 20" x 20" x 2" deep gravel (washed stone) bed. This "receiving area" shall begin where the end cap is placed against the SPC.

Inlet Pipe

- A 1-1/2" to 3" PVC pipe shall be used as an inlet pipe. The contractor must use an appropriate-sized hole saw to create an entrance hole for the 1-1/2" to 3" PVC inlet pipe in the end cap.
- The inlet pipe shall end with an elbow (90 degree fitting), the center of which is to be located inside the chamber void space directly over the center of the receiving area, pointing downward (see drawing on page 17).
- The inlet pipe shall be firmly embedded on the outside of the chamber to prevent movement or settling during system backfill.

Inspection Pipe

- 4" Sch. 40 or 4" PVC pipe shall be used for the observation port.

- Selected pipe should be installed using appropriate coupler. Coupler should seat on SPC at knockout provided in center corrugation.
- Pipe going up to grade should be cut to appropriate length. Pipe going into chamber void should be cut very short, to allow for adequate length so as to secure installation through knockout, but not so long as to interfere with the system inlet pipe.

Vent Pipe

- Install 3" or 4" PVC outlet pipe into each end cap (note: a hole saw is required for 3" pipe).
- Interconnect (manifold) all outlet pipes using appropriate PVC fittings.
- Prepare a vent pipe by drilling a minimum of 12 – 5/8" diameter holes into the upper 8" of the pipe, to provide for adequate air movement.
- Install vent pipe. The vent pipe shall be 3" or 4" PVC, and shall be installed into the roof knockout of the last chamber in the upper chamber line (note: a hole saw is required for 3" pipe). The pipe shall be secured at the chamber using a coupler, and extend into the chamber void only so far as necessary to stay in place.
- Complete the vent pipe with a Sch. 40 cap extending 12" above the ground surface.

Note:

This method of providing ventilation is only one way in which the chamber line may be vented. Other means of providing effective ventilation may be allowed by the state and/or local authority, including use of the observation ports.

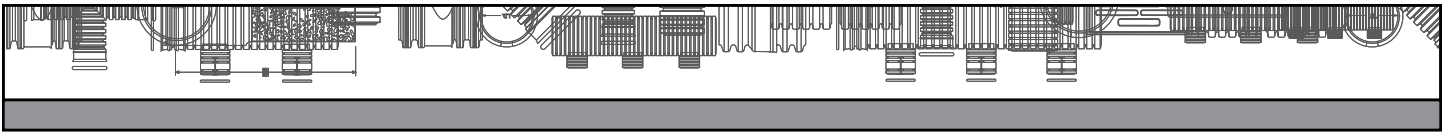

Additional Configurations:

**Pressure Dispersal:
Detail with Arc Side Port Coupler**

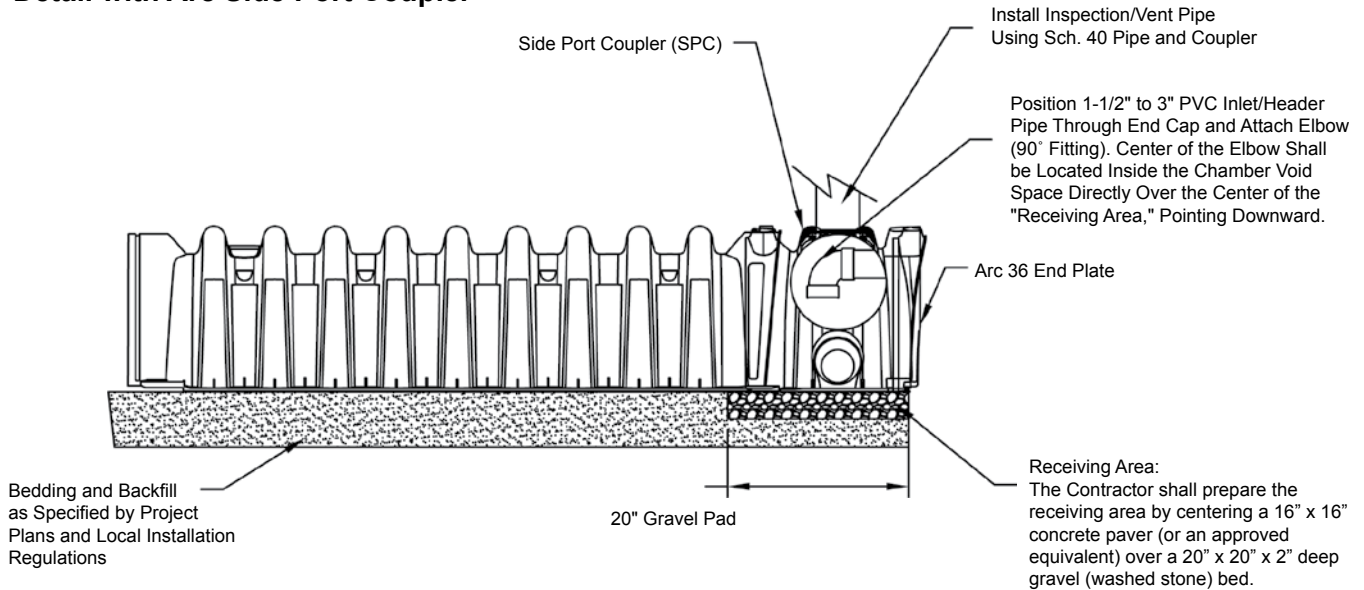

**Pressure Dispersal:
Observation Port/Vent Pipe**

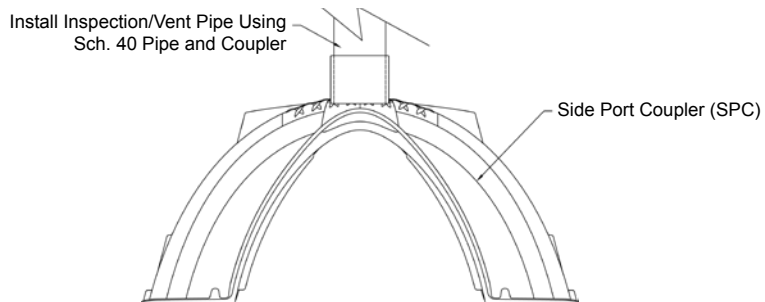

V. Pressure Dispersal

Approved pressure dispersal devices and methods include LPP and Drip.

**Pressure Dispersal:
Pipe Support Installation Cross Section**

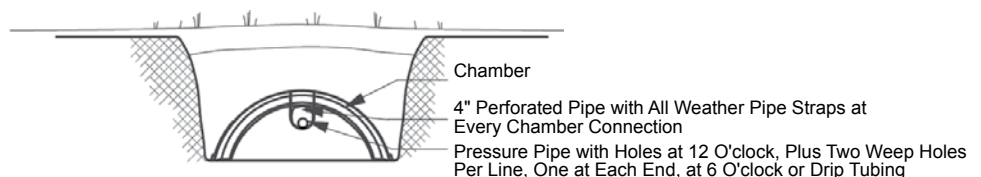

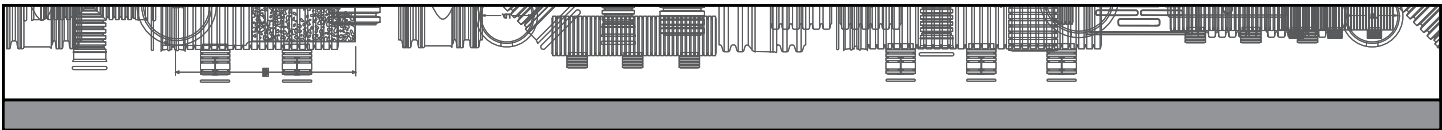

SYSTEM SIZING CHARTS

Arc 36 Systems: 4.61 FT²/LF - 35% I/A Reduction

		Conventional Stone and Pipe Trench			Arc 36 Model					
Textural Group	Natural Soil LTAR (gpd/sf)	2 BR	3 BR	4 BR	2 BR		3 BR		4 BR	
		Trench Length (ft)	Trench Length (ft)	Trench Length (ft)	Trench Length (ft)	Chambers Required (ft)	Trench Length (ft)	Chambers Required (ft)	Trench Length (ft)	Chambers Required (ft)
I Sands	1.0	80	120	160	52	11	78	16	104	21
	0.9	89	133	178	58	12	87	18	116	24
II Coarse Loams	0.8	100	150	200	65	13	98	20	130	26
	0.7	114	171	229	74	15	112	23	149	30
III Fine Loams	0.6	133	200	267	87	18	130	26	174	35
	0.5	160	240	320	104	21	156	32	208	42
	0.4	200	300	400	130	26	195	39	260	52
IV Clays	0.3	267	400	533	174	35	260	52	347	70
	0.2	400	600	800	260	52	390	78	521	105
	0.1	800	1,200	1,600	521	105	781	157	1,041	209

Arc 36 Systems: 4.0 FT²/LF - 25% Approved System Status Reduction

		Conventional Stone and Pipe Trench			Arc 36 Model					
Textural Group	Natural Soil LTAR (gpd/sf)	2 BR	3 BR	4 BR	2 BR		3 BR		4 BR	
		Trench Length (ft)	Trench Length (ft)	Trench Length (ft)	Trench Length (ft)	Chambers Required (ft)	Trench Length (ft)	Chambers Required (ft)	Trench Length (ft)	Chambers Required (ft)
I Sands	1.0	80	120	160	60	12	90	18	120	24
	0.9	89	133	178	67	14	100	20	133	27
II Coarse Loams	0.8	100	150	200	75	15	113	23	150	30
	0.7	114	171	229	86	18	129	26	171	35
III Fine Loams	0.6	133	200	267	100	20	150	30	200	40
	0.5	160	240	320	120	24	180	36	240	48
	0.4	200	300	400	150	30	225	45	300	60
IV Clays	0.3	267	400	533	200	40	300	60	400	80
	0.2	400	600	800	300	60	450	90	600	120
	0.1	800	1,200	1,600	600	120	900	180	1,200	240

11" Standard Systems: 4.61 FT²/LF - 35% I/A Reduction

		Conventional Stone and Pipe Trench			11" Standard Model BioDiffuser					
Textural Group	Natural Soil LTAR (gpd/sf)	2 BR	3 BR	4 BR	2 BR		3 BR		4 BR	
		Trench Length (ft)	Trench Length (ft)	Trench Length (ft)	Trench Length (ft)	Chambers Required (ft)	Trench Length (ft)	Chambers Required (ft)	Trench Length (ft)	Chambers Required (ft)
I Sands	1.0	80	120	160	52	9	78	13	104	17
	0.9	89	133	178	58	10	87	14	116	19
II Coarse Loams	0.8	100	150	200	65	11	98	16	130	21
	0.7	114	171	229	74	12	112	18	149	24
III Fine Loams	0.6	133	200	267	87	14	130	21	174	28
	0.5	160	240	320	104	17	156	25	208	34
	0.4	200	300	400	130	21	195	32	260	42
IV Clays	0.3	267	400	533	174	28	260	42	347	56
	0.2	400	600	800	260	42	390	63	521	84
	0.1	800	1,200	1,600	521	84	781	125	1,041	167

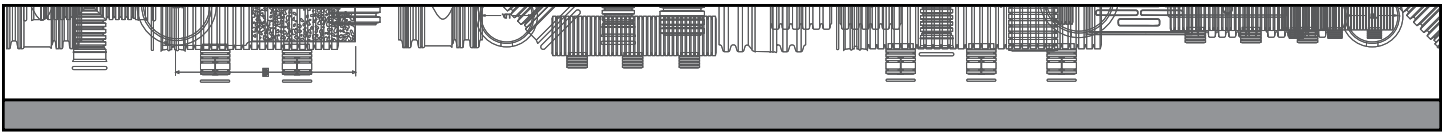

SYSTEM SIZING CHARTS: (continued)

11" Standard Systems: 4.0 FT²/LF - 25% Approved System Status Reduction										
		Conventional Stone and Pipe Trench			11" Standard Model BioDiffuser					
Textural Group	Natural Soil LTAR (gpd/sf)	2 BR Trench Length (ft)	3 BR Trench Length (ft)	4 BR Trench Length (ft)	2 BR Trench Length (ft) Chambers Required		3 BR Trench Length (ft) Chambers Required		4 BR Trench Length (ft) Chambers Required	
		I Sands	1.0	80	120	160	60	10	90	15
	0.9	89	133	178	67	11	100	16	133	22
II Coarse Loams	0.8	100	150	200	75	12	113	18	150	24
	0.7	114	171	229	86	14	129	21	171	28
III Fine Loams	0.6	133	200	267	100	16	150	24	200	32
	0.5	160	240	320	120	20	180	29	240	39
	0.4	200	300	400	150	24	225	36	300	48
IV Clays	0.3	267	400	533	200	32	300	48	400	64
	0.2	400	600	800	300	48	450	72	600	96
	0.1	800	1,200	1,600	600	96	900	144	1,200	192

Arc 24 Systems: 3.0 FT²/LF										
		Conventional Stone and Pipe Trench			Arc 24 Model					
Textural Group	Natural Soil LTAR (gpd/sf)	2 BR Trench Length (ft)	3 BR Trench Length (ft)	4 BR Trench Length (ft)	2 BR Trench Length (ft) Chambers Required		3 BR Trench Length (ft) Chambers Required		4 BR Trench Length (ft) Chambers Required	
		I Sands	1.0	80	120	160	80	16	120	24
	0.9	89	133	178	89	18	133	27	178	36
II Coarse Loams	0.8	100	150	200	100	20	150	30	200	40
	0.7	114	171	229	114	23	171	35	229	46
III Fine Loams	0.6	133	200	267	133	27	200	40	267	54
	0.5	160	240	320	160	32	240	48	320	64
	0.4	200	300	400	200	40	300	60	400	80
IV Clays	0.3	267	400	533	267	54	400	80	533	107
	0.2	400	600	800	400	80	600	120	800	160
	0.1	800	1,200	1,600	800	160	1,200	240	1,600	320

Bio 3 Systems: 3.0 FT²/LF										
		Conventional Stone and Pipe Trench			Bio 3 Model					
Textural Group	Natural Soil LTAR (gpd/sf)	2 BR Trench Length (ft)	3 BR Trench Length (ft)	4 BR Trench Length (ft)	2 BR Trench Length (ft) Chambers Required		3 BR Trench Length (ft) Chambers Required		4 BR Trench Length (ft) Chambers Required	
		I Sands	1.0	80	120	160	80	12	120	17
	0.9	89	133	178	89	13	133	19	178	25
II Coarse Loams	0.8	100	150	200	100	14	150	21	200	28
	0.7	114	171	229	114	16	171	24	229	32
III Fine Loams	0.6	133	200	267	133	19	200	28	267	38
	0.5	160	240	320	160	23	240	34	320	45
	0.4	200	300	400	200	28	300	42	400	56
IV Clays	0.3	267	400	533	267	38	400	56	533	75
	0.2	400	600	800	400	56	600	84	800	112
	0.1	800	1,200	1,600	800	112	1,200	168	1,600	224

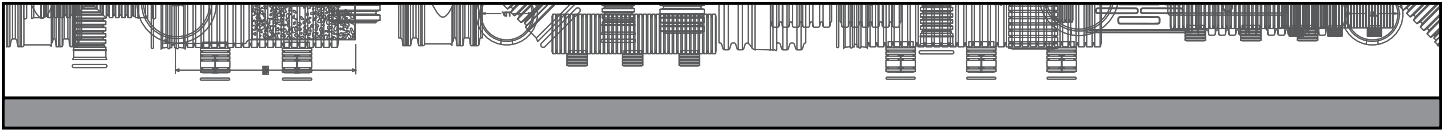

NOTES/COMMENTS

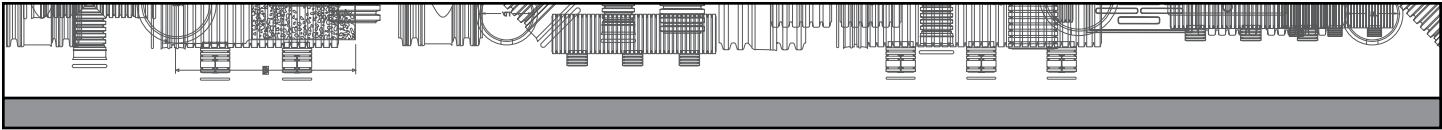

NOTES/COMMENTS

Innovation in product, process and technology.

That's ADS and Hancor.

Beginning with single wall corrugated polyethylene pipe, ADS and Hancor have continually introduced drainage products that have set the industry standard – bringing to market a remarkable alternative to concrete and steel pipe. Our commitment to being the best means that we continue to refine the structural design of our pipe and redefine the limits of its application in the structural design community.



800-733-3555
www.ads-pipe.com



888-FOR PIPE (367-7473)
www.hancor.com