

**INSTALLATION INSTRUCTIONS FOR RETROFIT AND COMPLETE VALVE  
INSTALLATION FOR SLOAN SOLIS®, SOLAR POWERED,  
SINGLE AND DUAL FLUSH WATER CLOSETS AND URINALS**

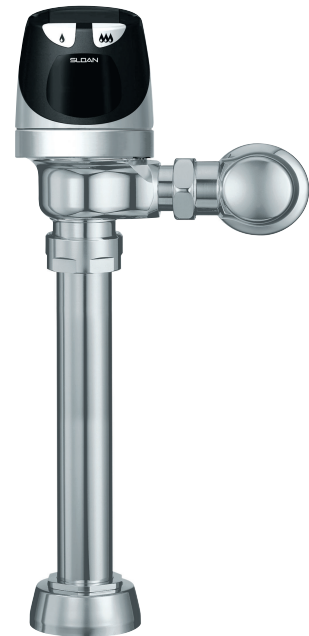

**8100 Series Complete Flushometer Models**

8100 Series Sloan SOLIS® Valves are complete Flushometer Valves and ideal for new installations.

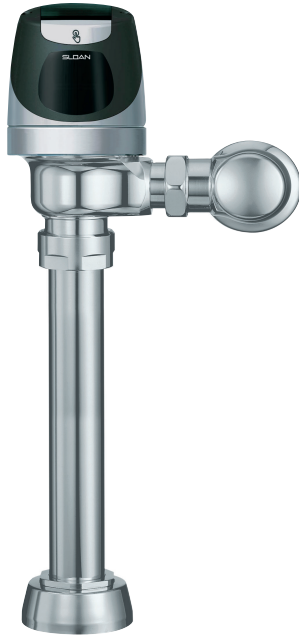

**RESS Series Retrofit Conversion Kit Models**

RESS Sloan SOLIS® Models are used to convert existing Flushometers to Solar Powered, Sensor Activated.

**Sloan SOLIS® Dual Flush Water Closet Models can be furnished for the following:**

- 1.1 gpf/4.2 Lpf                      Reduced Flush
- 1.6 gpf/6.0 Lpf (Full Flush)      For Low Consumption Bowls

**Sloan SOLIS® Water Closet Models can be furnished for the following:**

- 1.28 gpf/4.7 Lpf                      High Efficiency
- 1.6 gpf/6.0 Lpf                      For Low Consumption Bowls

**Sloan SOLIS® Urinal Models can be furnished for the following:**

- 0.13 gpf/0.5 Lpf                      High Efficiency
- 0.25 gpf/0.9 Lpf                      High Efficiency
- 0.5 gpf/1.9 Lpf                      High Efficiency
- 1.0 gpf/3.8 Lpf                      For Low Consumption Urinals
- 1.5 gpf/5.7 Lpf                      For older Siphon Jet Urinals



**LIMITED WARRANTY**

Sloan Valve Company warrants its Sloan SOLIS® Flushometers to be made of first class materials, free from defects of material or workmanship under normal use and to perform the service for which they are intended in a thoroughly reliable and efficient manner when properly installed and serviced, for a period of three years (1 year for special finishes) from date of purchase. During this period, Sloan Valve Company will, at its option, repair or replace any part or parts which prove to be thus defective if returned to Sloan Valve Company, at customer's cost, and this shall be the sole remedy available under this warranty. No claims will be allowed for labor, transportation or other incidental costs. This warranty extends only to persons or organizations who purchase Sloan Valve Company's products directly from Sloan Valve Company for purpose of resale. This warranty does not cover the life of the batteries.

**THERE ARE NO WARRANTIES WHICH EXTEND BEYOND THE DESCRIPTION ON THE FACE HEREOF. IN NO EVENT IS SLOAN VALVE COMPANY RESPONSIBLE FOR ANY CONSEQUENTIAL DAMAGES OF ANY MEASURE WHATSOEVER.**

# VALVE ROUGH-IN

## Water Closet Installation

Model 8110/8111, 8113, 8115, and 8116  
Reference for RESS-C Retrofit

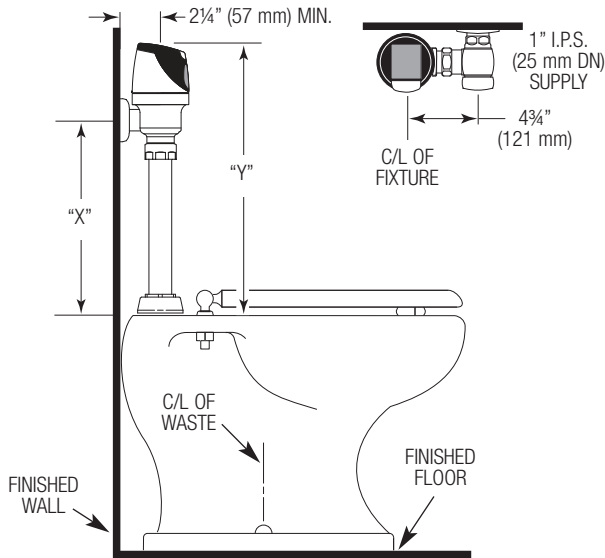

Model	"X"	"Y"
8111†	29" (737 mm)	29" (737 mm)
8113*	16" (406 mm)	21" (533 mm)
8115‡	24" (610 mm)	29" (737 mm)
8116‡	27" (686 mm)	32" (813 mm)

### When installing the Sloan SOLIS® in a handicap stall:

Per the ADA Guidelines (section 604.9.4) it is recommended that the grab bars be split or shifted to the wide side of the stall.

† For new installations, Sloan strongly recommends the use of our Model 8111 which has a shorter installation height.

\* Use the Model 8113 when toilet seat with covers are being used.

‡ Model 8115 & 8116 valves are designed for installations where the water supply is roughed-in 24" - 27" (610 mm - 686 mm) above the top of the water closet.

## Typical Water Closet Installation

Model 8137  
Reference for RESS-C Retrofit

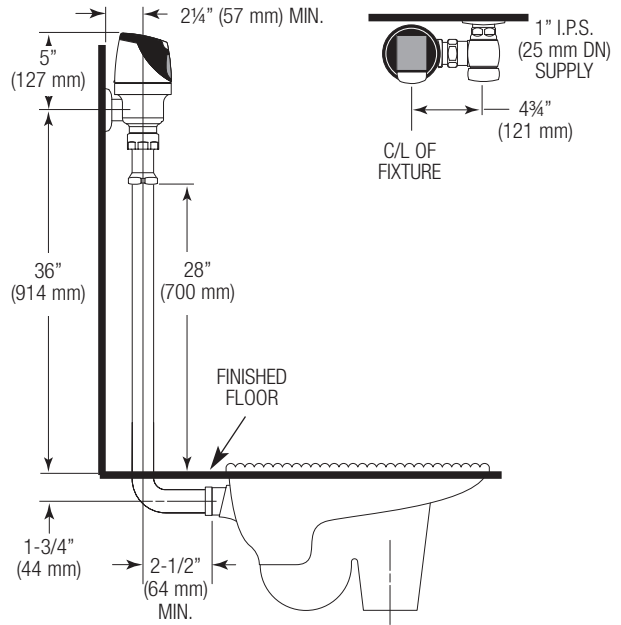

## Typical Urinal Installation

Models 8180 & 8186  
Reference for RESS-U Retrofit

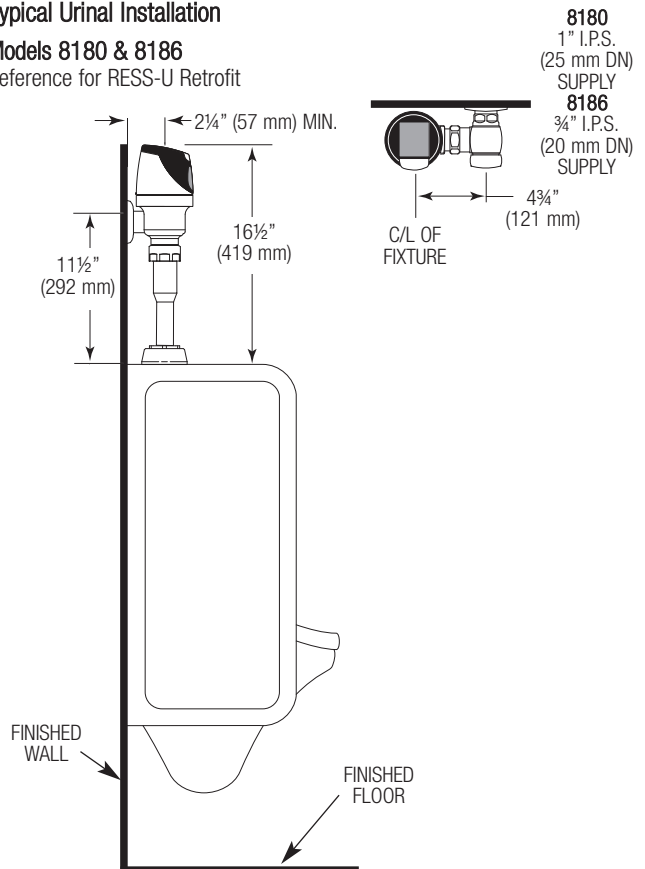

**!!! IMPORTANT !!!**

With the exception of Control Stop Inlet, DO NOT use pipe sealant or plumbing grease on any valve component or coupling!

**!!! IMPORTANT !!!**

Never open Control Stop to where the flow from the valve exceeds the flow capability of the fixture. In the event of a valve failure, the fixture must be able to accommodate a continuous flow from the valve.

**!!! IMPORTANT !!!**

Protect the chrome or special finish of Sloan Flushometers — DO NOT USE toothed tools to install or service these valves. Use a Sloan A-50 Super-Wrench™, Sloan A-109 Plier Wrench or smooth jawed spud wrench to secure all couplings. Also see “Care and Cleaning” section of this manual.

**!!! IMPORTANT !!!**

The Strap Wrench provided with Sloan SOLIS® is a convenience tool and is not to be used to remove or install the Flushometer Couplings. Use Strap Wrench ONLY to install Sloan SOLIS® Locking Ring.

**!!! IMPORTANT !!!**

This product contains mechanical and/or electrical components that are subject to normal wear. These components should be checked on a regular basis and replaced as needed to maintain the valve’s performance.

Please take the time to read this manual to ensure proper product installation and longevity. Also, please visit our website to download our most recent documentation for this product.

If you have questions about how to install your Sloan Flushometer, consult your local Sloan Representative or call Sloan Installation Engineering Department at:

1-888-SLOAN-14 (1-888-756-2614)

**PRIOR TO INSTALLING THE SLOAN SOLIS® FLUSHOMETER**

Prior to installing the Sloan SOLIS® Flushometer, install the items listed below as illustrated in the Rough-in Diagram. (New installations only.)

- Closet or Urinal fixture
- Drain line
- Water supply line

**Important:**

- **INSTALL ALL PLUMBING IN ACCORDANCE WITH APPLICABLE CODES AND REGULATIONS.**
- **WATER SUPPLY LINES MUST BE SIZED TO PROVIDE AN ADEQUATE VOLUME OF WATER FOR EACH FIXTURE.**
- **WHEN INSTALLING A FLUSHOMETER, IT IS IMPORTANT THAT THE FLUSH MODEL MATCHES THE REQUIREMENTS OF THE PLUMBING FIXTURE.**
- **FLUSH ALL WATER LINES PRIOR TO MAKING CONNECTIONS.**

The Sloan SOLIS® is designed to operate with 15 to 100 PSI (104 to 689 kPa) of water pressure. **THE MINIMUM PRESSURE REQUIRED TO THE VALVE IS DETERMINED BY THE TYPE OF FIXTURE SELECTED.** Consult fixture manufacturer for pressure requirements.

Most Low Consumption water closets (1.6 gallon/6 liter) require a minimum flowing pressure of 25 psi (172 kPa).

**TOOLS REQUIRED FOR INSTALLATION**

- Slotted screwdriver to adjust control stop.
- Sloan A-50 Super-Wrench™, Sloan A-109 Plier Wrench or smooth jawed spud wrench for couplings.
- Trimpot adjustment screwdriver (supplied) to adjust range, if necessary.
- Strap wrench (supplied) to install Sloan SOLIS® to valve body.
- 7/64" hex wrench (supplied) to secure Sloan SOLIS® cover to base plate.
- 5/64" hex wrench to secure water Supply Flange.

**1 - For Complete Valve Installation, Start here. For RESS Retrofit Installations, Start at Step 6. Install Optional Sweat Solder Adapter (only if your supply pipe does not have a male thread)**

- A** Measure from finished wall to C/L of Fixture Spud. Cut pipe 1¼" (32 mm) shorter than this measurement. Chamfer O.D. and I.D. of water supply pipe.
- B** Slide Threaded Adapter fully onto pipe.
- C** Sweat solder the Adapter to pipe.

**!!! IMPORTANT !!!**

With the exception of Control Stop Inlet, DO NOT use pipe sealant or plumbing grease on any valve component or coupling!

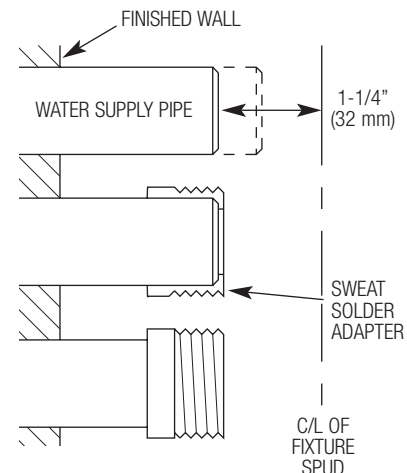

## 2 - Install Cover Tube, Wall Flange and Control Stop to Supply Pipe

**A** Measure from finished wall to first thread of Adapter or threaded supply pipe (dimension "X"). Cut Cover Tube to this length.

**B** Slide Cover Tube over pipe. Slide Wall Flange over Cover Tube until against wall.

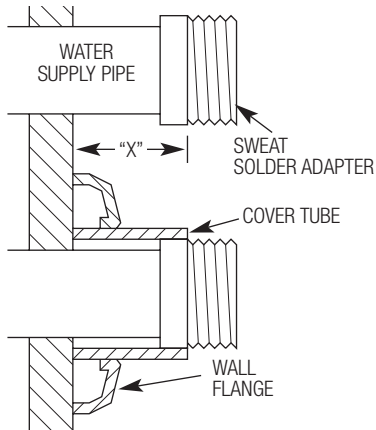

**C** Thread Control Stop onto pipe. Tighten with a wrench.

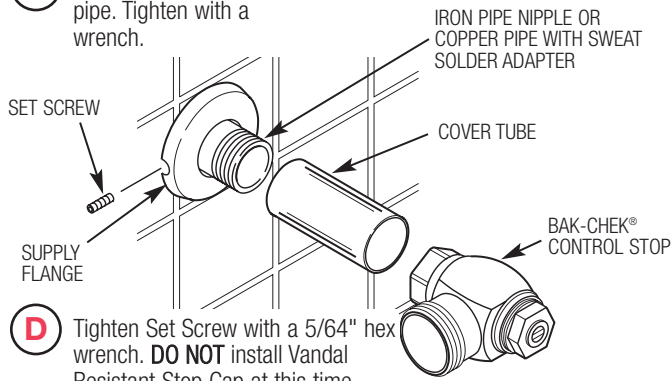

**D** Tighten Set Screw with a 5/64" hex wrench. **DO NOT** install Vandal Resistant Stop Cap at this time.

## 3 - Flush Out Supply Line

**A** Open Control Stop.

**CLOCKWISE** CLOSSES CONTROL STOP

**COUNTERCLOCKWISE** OPENS CONTROL STOP

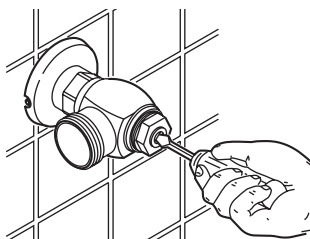

**B** Turn on water supply to flush line of any debris or sediment.

**C** Close Control Stop.

## 4 - Install Vacuum Breaker Flush Connection

### NOTE

If cutting Vacuum Breaker Tube to size, note that Critical Line (C/L) on Vacuum Breaker must typically be 6" (152 mm) above fixture. Consult Code for details.

**A** Slide Spud Coupling, Nylon Slip Gasket, Rubber Gasket and Spud Flange over Vacuum Breaker Tube.

**B** Insert Tube into Fixture Spud.

**C** Hand tighten Spud Coupling onto Fixture Spud.

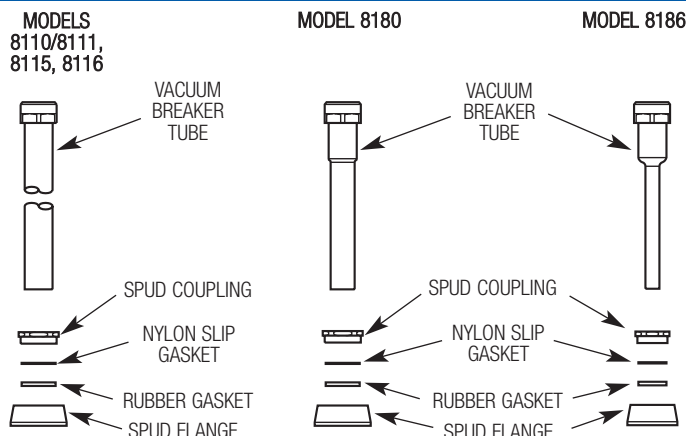

## 5 - Install Flushometer

**A** Lubricate tailpiece O-ring with water. Insert Adjustable Tailpiece into Control Stop. Tighten Tailpiece Coupling by hand.

**B** Align Flushometer directly above the Vacuum Breaker Flush Connection by sliding the Flushometer Body IN or OUT as needed. Tighten Vacuum Breaker Coupling by hand.

**C** Align Flushometer Body and securely tighten first the Tailpiece Coupling (1), then the Vacuum Breaker Coupling (2), and finally the Spud Coupling (3). Use a wrench to tighten these couplings in the order shown.

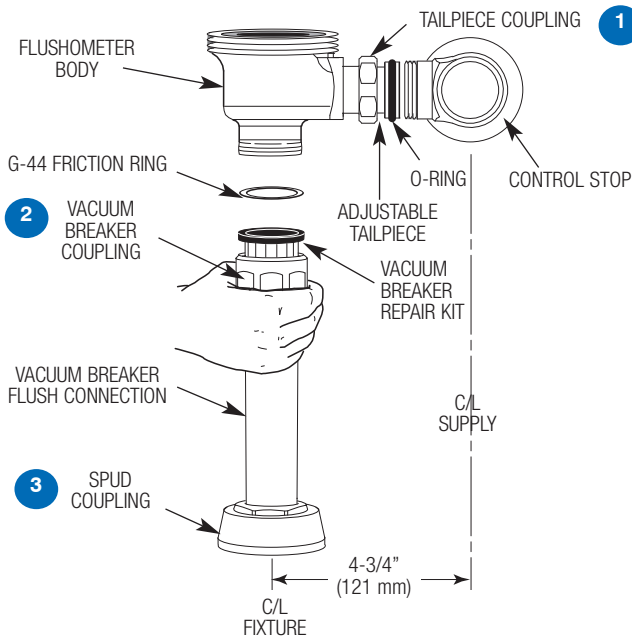

Maximum adjustment of the Sloan Adjustable Tailpiece is 1/2" (13 mm) IN or OUT from the standard 4 3/4" (121 mm) (centerline of Flushometer to centerline of Control Stop).

If roughing-in measurement exceeds 5 1/4" (133 mm), consult factory for longer tailpiece.

## 6 - When Retrofitting an Existing Valve, Start Here. Remove Components from Existing Flushometer (RESS Retrofit Installations Only)

- A** Remove Control Stop Cap.
- B** Turn off water supply at Control Stop. Push Valve Handle to relieve water pressure.
- C** Remove Outside and Inside Covers and old Inside Parts Kit.
- D** Remove old Handle Assembly and Gasket.
- E** Install Chrome Handle Cap with Gasket to handle opening on Flushometer Body. Tighten Chrome Handle Cap securely.

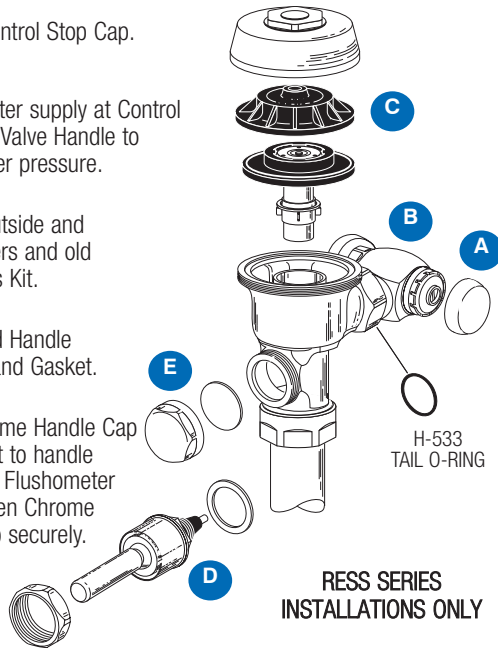

**NOTE:** An extra H-533 Tail O-ring is included in the event leakage occurs if the valve is repositioned during the installation of the new Sloan SOLIS®. Use only as needed.

## 7 - Sloan SOLIS® Flush Volume (RESS Retrofit Installations Only)

The Flush Volume of the Sloan SOLIS® is controlled by the Regulator or Cartridge in the Flex Tube Diaphragm Kit. Regulators are identified by color.

### Reference Chart

Fixture & Flush	Regulator Color
1.28 gpf (4.7 Lpf) Closet	Green
1.6 gpf (6.0 Lpf) Closet	Green
0.5 gpf (1.9 Lpf) Urinal	Green
1.0 gpf (3.8 Lpf) Urinal	Green
1.5 gpf (5.7 Lpf) Urinal	Black

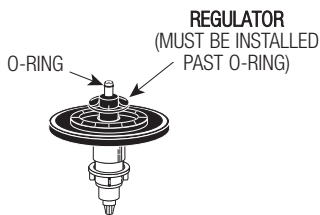

### Urinal Cartridge

0.13 gpf (0.5 Lpf)  
0.25 gpf (0.9 Lpf)



**Note:** A 0.5 gpf (1.9 Lpf) Urinal kit can be converted to a 1.0 gpf (3.8 Lpf) by cutting and removing the smooth A-164 Flow Ring from the Guide.

RESS-C and RESS-U SOLIS® valves are supplied with multiple Regulators to address multiple flushing applications. The product is shipped with its lowest flush volume configuration. To convert the flush to a higher flushing volume, simply change the Regulator.

When installing a new Regulator on a Flex Tube Diaphragm Kit, be sure to push the Regulator past the O-ring when installing.

**Note:** Never use more water than needed. Low Consumption water closets and urinals will not function properly on excess water.

## 8A - Assemble Flex Tube Diaphragm to Sloan SOLIS Assembly (excluding 8186-0.13/0.25)

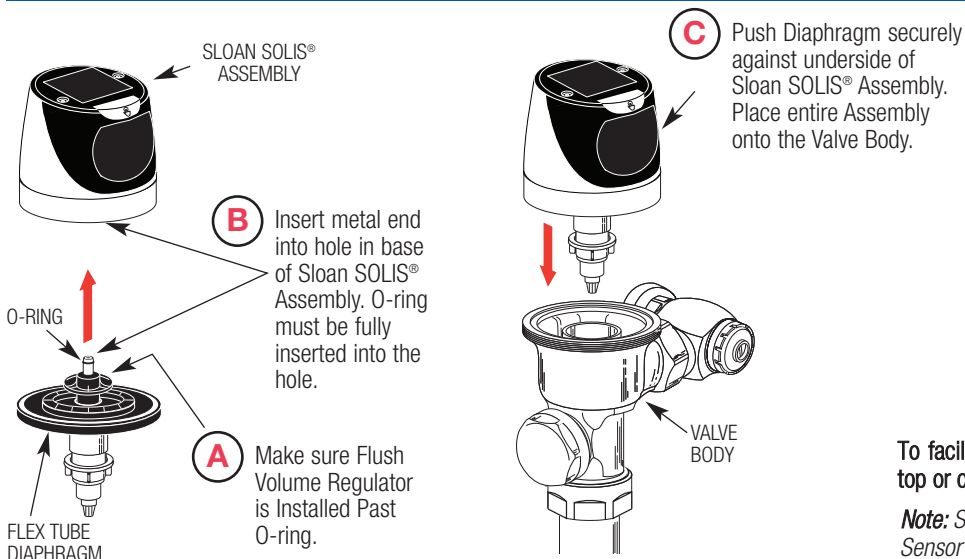

To facilitate installation, wet the diaphragm assembly (on top or completely).

**Note:** Sensor Lens must face directly forward. Rotating the Sensor to either side will decrease the Sensor's ability to detect a target.

## 8B - Assemble Cartridge to Sloan SOLIS Assembly (models 8186-0.13/0.25 only)

- A** Internal area of valve body should be cleaned of impurities and grime before installation to prevent possible lip seal leakage.

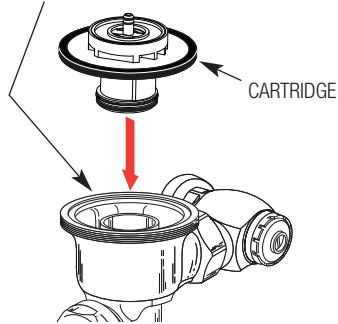

- C** Attach Solis Cover Assembly.

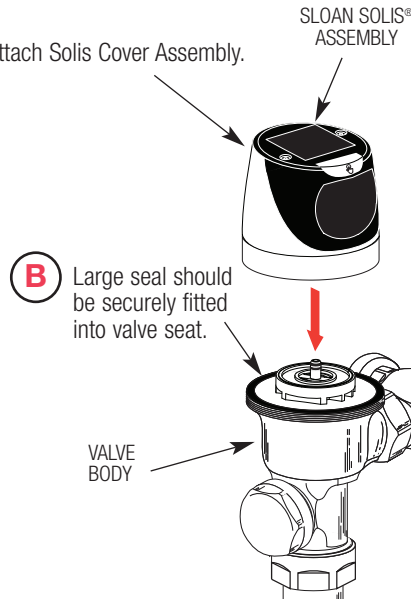

- B** Large seal should be securely fitted into valve seat.

**Note:** Sensor Lens must face directly forward. Rotating the Sensor to either side will decrease the Sensor's ability to detect a target.

## 9 - Tighten Locking Ring

- A** Thread Locking Ring onto Valve Body.

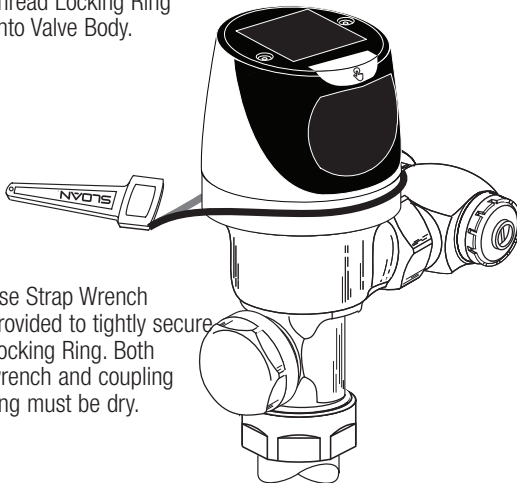

- B** Use Strap Wrench provided to tightly secure Locking Ring. Both wrench and coupling ring must be dry.

**Important:** The Locking Ring must be installed down past the valve body threads by at least one thread. If difficulty is experienced installing the Locking Ring, turn the Locking Ring back and forth, each time working it further down the threads. The Locking Ring will act as a thread chaser in the event there has been a build-up of matter on the threads of the old valve body.

If retrofitting the Sloan SOLIS® onto a Zurn valve body, a special Locking Ring must be used (identified by a machined groove around the ring). Order the Sloan SOLIS® with the "Z" variation to receive the unit supplied with this Ring.

## 10 - Remove Tape from Solar Panel and Sensor Window to activate.

- A** Remove the Tape located over Solar Panel.

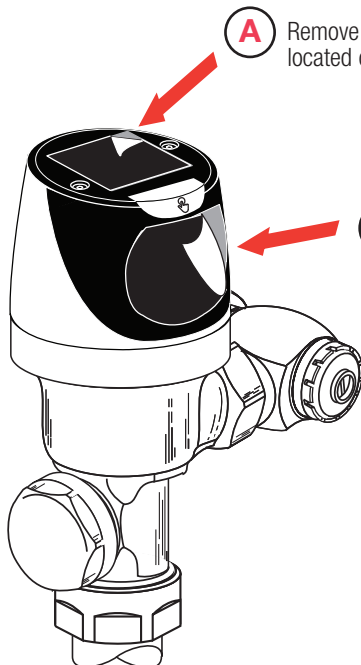

- B** Remove the Tape located over Sensor Window.

- C** For the first ten (10) minutes of operation, a Visible Light flashes in the Sensing Window of the Sloan SOLIS® Flushometer when a user is detected.

## 11 - Test Sensor Operation

The Sloan SOLIS® has a factory set sensing range:

Water Closet Models - 22" to 42" (559 mm to 1067 mm) and Urinal Models - 15" to 30" (381 mm to 762 mm)

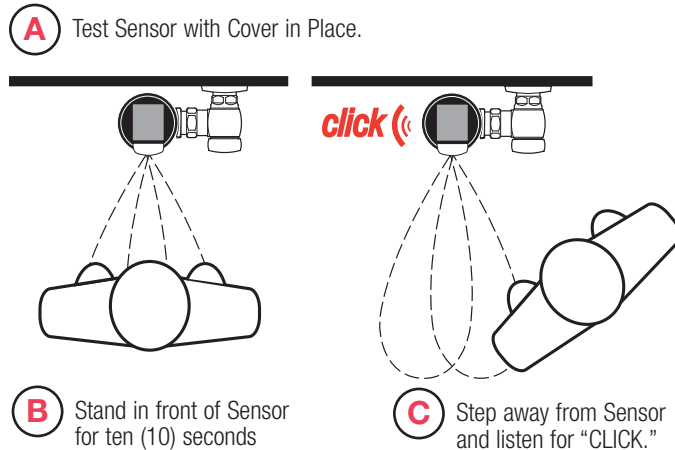

The Factory setting should be satisfactory for most installations. If a range adjustment is required, refer to the Range Adjustment instructions on this page.

## 12 - Adjust Control Stop and Install Vandal Resistant Stop Cap

- A** Open Control Stop COUNTERCLOCKWISE ½ turn from closed position.
- B** Activate Flushometer by placing hand in front of Sloan SOLIS® Sensor Lens for ten (10) seconds (or press override button) and then moving it away.
- C** Adjust Control Stop after each flush until the rate of flow delivered properly cleanses the fixture.
- 

**Important:** The Sloan Flushometer is engineered for quiet operation. Excessive water flow creates noise, while too little water flow may not satisfy the needs of the fixture. Proper adjustment is made when plumbing fixture is cleansed after each flush without splashing water out from the lip AND a quiet flushing cycle is achieved.

**Important:** The Control Stop should never be opened to the point where the flow from the valve exceeds the flow capability of the fixture. In the event of a valve failure, the fixture must be able to accommodate a continuous flow from the valve.

- D** Install Control Stop Cap onto Control Stop. For RESS retrofit applications, reuse Stop Cap from existing valve. In complete valve installations, a new Stop Cap is provided. Follow the instructions packaged with the Free Spinning Vandal Resistant Stop Cap.

## OPERATION

1. A continuous, INVISIBLE light beam is emitted from the Sloan SOLIS® Sensor.
2. As the user enters the beam's effective range, 22 to 42 inches (559 mm to 1067 mm) for closet installations and 15 to 30 inches (381 mm to 762 mm) for urinal installations, the beam is reflected into the Scanner Window to activate the Output Circuit. Once activated, the Output Circuit continues in a "hold" mode for as long as the user remains within the effective range of the sensor. For Dual Flush models, if the user stays longer than 65 seconds, a full flush will automatically initiate when the user leaves. For Single Flush models, once the user steps away, a full flush will automatically initiate.
3. For Dual Flush models, once a user is detected, if the user leaves in 65 seconds or less, a reduced flush will automatically initiate. The circuit automatically resets and is ready for the next user. For Single Flush models, when the user steps away, this initiates a full flush. The circuit automatically resets and is ready for the next user.
4. In addition to the above the Sloan SOLIS® Urinal incorporates a standard deferred flushing mode feature that accommodates the high volume usage seen in stadiums or similar high attendance facilities.

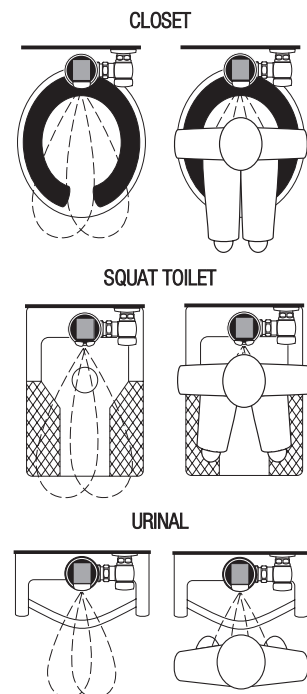

## RANGE ADJUSTMENT (ADJUST ONLY IF NECESSARY)

The Sloan SOLIS® has a factory set sensing range:

Water Closet Models - 22" to 42" (559 mm to 1067 mm)

Urinal Models - 15" to 30" (381 mm to 762 mm)

The Factory setting should be satisfactory for most installations.

If the range is too short (i.e., not picking up users) or too long (i.e., picking up opposite wall or stall door) the range can be adjusted.

**Note:** Water does not have to be turned off to adjust range.

Loosen the two Screws on top of the unit and remove cover. Remove the Rubber Plug from top of Electronic Sensor Module to uncover the Potentiometer.

### RANGE ADJUSTMENT PROCEDURE

For the first ten (10) minutes of operation, a Visible Light flashes in the Sensing Window of the Sloan SOLIS® Flushometer when a user is detected. This Visible Light feature can be reactivated after ten (10) minutes by opening and closing the Battery Compartment Door. Check the range by stepping toward the unit until the Light flashes, indicating the Sensor's maximum detection limit. Adjust the Range Potentiometer Screw located on top of the Sensor Module a few degrees CLOCKWISE to increase the range or a few degrees COUNTER-CLOCKWISE to decrease the range. Repeat this adjustment until the desired range is achieved.

**Always Determine the Sensing Range with Metal Cover and Lens Window On Top of the Unit.**

**Important:** Adjust in small increments only! Range Potentiometer Adjustment Screw rotates only  $\frac{3}{4}$  of a turn; **DO NOT** over-rotate.

When range adjustment is satisfactory, replace the Rubber Plug. Reinstall Cover and tighten the two Screws on top of the unit.

COUNTER-CLOCKWISE

CLOCKWISE

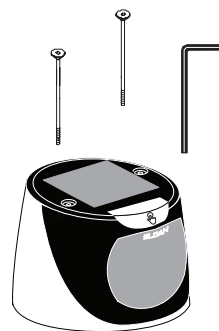
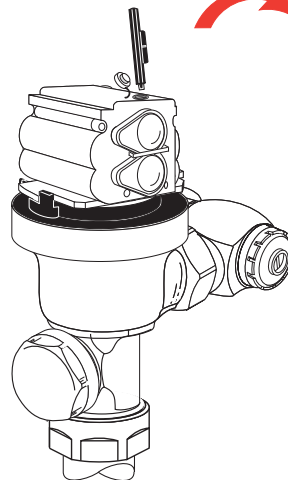

## BATTERY REPLACEMENT

When required, replace batteries with four (4) Alkaline AA-Size Batteries.

**Note:** Water does not have to be turned off to replace Batteries.

Loosen the two (2) Screws on top of unit. Remove the complete Cover Assembly. Lift the Sensor Module from its Plate. Unplug the Electrical Connector from Battery Compartment Cover. Loosen the Retaining Screw on Battery Compartment Cover. Remove Battery Compartment Cover and old Batteries. Install four (4) fresh Alkaline AA-Size Batteries **exactly** as illustrated.

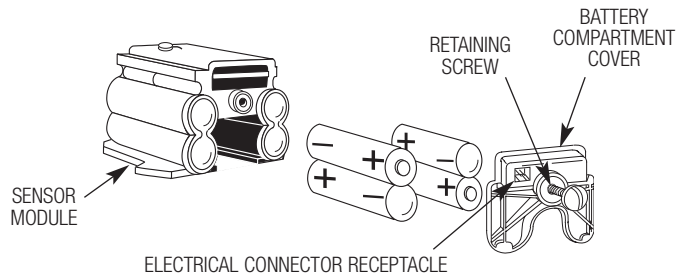
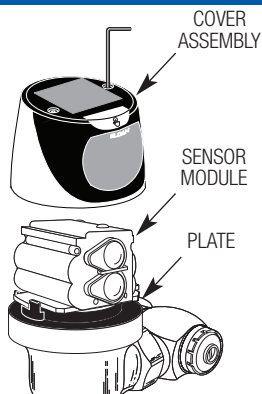

Install Battery Compartment Cover and secure with Retaining Screw. Make certain that Battery Compartment Cover is fully compressed against Gasket to provide a seal; **Do Not** overtighten. Plug the Electrical Connector into the Battery Compartment Cover. Reinstall the Sensor Module onto the Plate. Reinstall the complete Cover Assembly onto the Plate. Tighten the two (2) Screws on top of the unit.

## CARE AND CLEANING OF CHROME AND SPECIAL FINISHES

**DO NOT** use abrasive or chemical cleaners to clean Flushometers as they may dull the luster and attack the chrome or special decorative finishes. Use **ONLY** soap and water, then wipe dry with clean cloth or towel.

While cleaning the bathroom tile, the Flushometer should be protected from any splattering of cleaner. Acids and cleaning fluids can discolor or remove chrome plating.

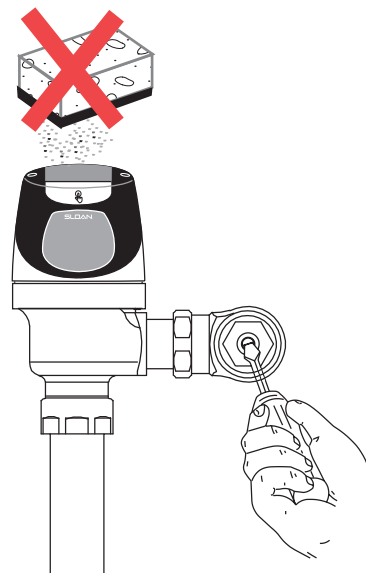

## TROUBLESHOOTING GUIDE

### 1. Sensor Flashes Continuously Only When User Steps Within Range.

- A. Unit in Start-Up mode; no problem. This feature is active for the first ten (10) minutes of operation.

### 2. Valve Does Not Flush; Sensor Not Picking Up User.

- A. Range too short; increase the range.

### 3. Valve Does Not Flush; Sensor Picking Up Opposite Wall or Surface, or Only Flushes When Someone Walks By. Light Flashes Continuously for First 10 Minutes Even with No One in Front of the Sensor.

- A. Range too long; shorten range.

### 4. Valve Does Not Flush Even After Adjustment.

- A. Range Adjustment Potentiometer set at full "max" or full "min" setting. Readjust Potentiometer away from full "max" or "min" setting.  
 B. Batteries completely used up; replace batteries.  
 C. Problem with Electronic Sensor Module; replace Electronic Sensor Module.

### 5. Unit Flashes 4 Quick Times When User Steps Within Range.

- A. Batteries low; replace batteries.

### 6. Valve Does Not Shut Off.

- A. Bypass Orifice in Diaphragm is clogged with dirt or debris, or Bypass is clogged by an invisible gelatinous film due to "over-treated" water. Remove Flex Tube Diaphragm and wash under running water.  
**Note:** Size of Orifice in the Bypass is of utmost importance for the proper metering of water by the valve. **DO NOT ENLARGE OR DAMAGE THIS ORIFICE.** Replace Flex Tube Diaphragm if cleaning does not correct the problem.  
 B. Dirt or debris fouling Stem or Flex Tube Diaphragm. Remove Flex Tube Diaphragm and wash under running water.  
 C. O-ring on Stem of Flex Tube Diaphragm or Cartridge is damaged or worn. Replace O-ring if necessary.  
 D. Problem with Electronic Sensor Module; replace Sensor Module.

### 7. Not Enough Water to Fixture.

- A. Wrong Flush Volume Regulator installed in Flex Tube Diaphragm Kit. Install the correct Regulator (see Step 7 of these instructions).  
 B. Wrong Sloan SOLIS® model installed; i.e., 1 gpf Urinal installed on 3.5 gal. Closet fixture. Replace with proper Sloan SOLIS® model.  
 C. Enlarged Bypass in Diaphragm. Replace Flex Tube Diaphragm.  
 D. Control Stop not adjusted properly. Readjust Control Stop.  
 E. Inadequate volume or pressure at supply. Increase water pressure or supply (flow) to valve. Consult factory for assistance.  
 F. Flow control in EBV-326-A cartridge assembly is dirty. Clean under running water and brush away debris.

### 8. Too Much Water to Fixture.

- A. Wrong Flush Volume Regulator installed in Flex Tube Diaphragm Kit. Install the correct Regulator (see Step 7 of these instructions).  
 B. Control Stop not adjusted properly. Readjust Control Stop.  
 C. Wrong Sloan SOLIS® model installed; i.e., 3 gpf Model installed on 1.0 or 1.5 gal. Urinal fixture. Replace with proper Sloan SOLIS® model.  
 D. Dirt in Diaphragm Bypass. Clean under running water or replace Flex Tube Diaphragm.  
 E. Flow control improperly removed from EBV-326-A cartridge Assembly. Replace cartridge assembly.

**Note:** The EBV-46-A Beam Deflector is not required or available for the Sloan SOLIS®.

**Note:** Troubleshooting also applies to the Sloan Solis Urinals.

Refer to the Sloan SOLIS® Flushometer Maintenance Guide for additional Troubleshooting and Repair Part information.

The Sloan SOLIS® Repair and Maintenance Guide is available at [www.sloanvalve.com](http://www.sloanvalve.com).

If further assistance is required, please contact the Sloan Valve Company Installation Engineering Department at: 1-888-SLOAN-14 (1-888-756-2614)

## RECOMMENDED WATER CLOSET WALL PLATE LOCATIONS

Centered over Flushometer

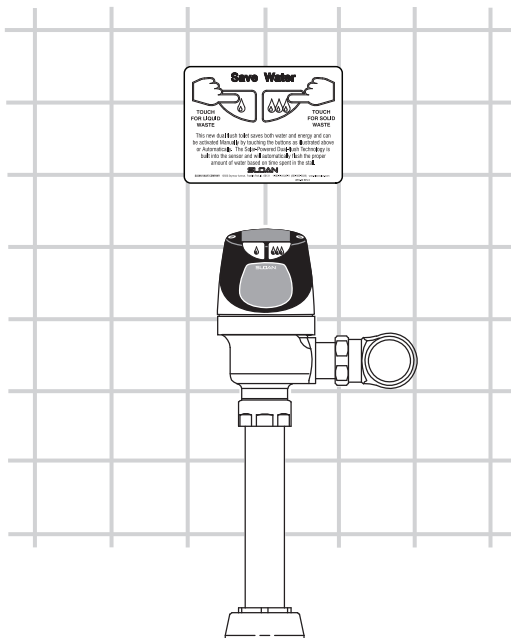

On Stall Door

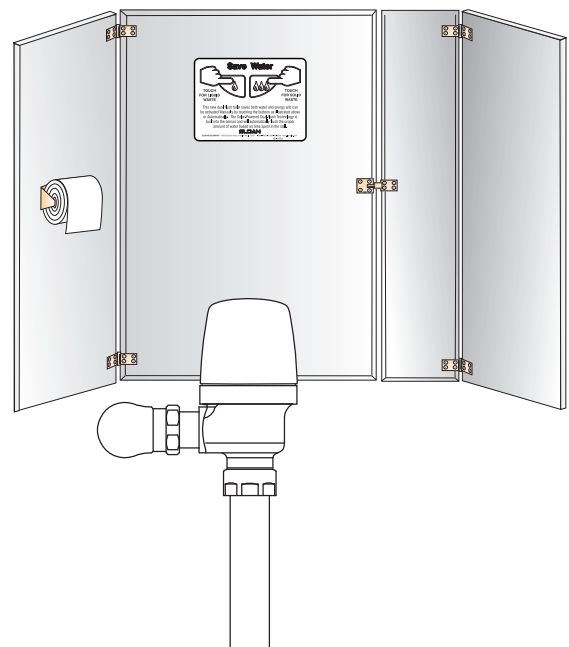

# PARTS LIST

Item #	Part #	Description
<b>Items Included with RESS Retrofit and Complete Sloan SOLIS® Valves</b>		
1	EBV-304-A	Cover/Sensor/Assembly - Closet Solis Electronic Single Button Flush
	EBV-320-A	Cover/Sensor/Assembly (Zurn) - Closet Solis Electronic Single Button Flush
	WES-24-A	Cover/Sensor/Assembly - Closet Solis Electronic Dual Flush
	WES-28-A	Cover/Sensor/Assembly (Zurn) - Closet Solis Electronic Dual Flush
	EBV-306-A	Cover/Sensor/Assembly - Urinal Solis Electronic Single Button
	EBV-321-A	Cover/Sensor/Assembly (Zurn) - Urinal Solis Electronic Single Button
2	EBV-311-A	Cover Assembly - Solis Electronic Dual Flush Flush
	EBV-309-A	Cover Assembly - Solis Electronic Single Button Flush
3	EBV-14	Locking Ring
	EBV-30	Locking Ring - for Zurn valves
4	EBV-312-A-C	Sensor Assembly Solis - Water Closet
	EBV-312-A-U	Sensor Assembly Solis - Urinal
	WES-33-A	Sensor Assembly Solis - Water Closet (Dual Flush)
5	EBV-134	Cover Rest Plate
6	EBV-145-A	Inside Cover Assembly (includes solenoid)
7	EBV-136-A	Solenoid
8	See Chart	Flex Tube Diaphragm Assembly
9	See Chart	Flush Volume Regulator
10	EBV-326-A	Cartridge Assembly (Models 8186-0.13/8186-0.25 only)
11	EBV-1017-A	Handle Cap
12	EBV-91	Range Adjustment Tool
13	EBV-22	Strap Wrench
14	EBV-137	7/64" Hex Wrench
15	WES-27	English Plate (Dual Flush only)
	WES-29	Spanish Plate (Dual Flush only)

## Items Included with Complete Sloan SOLIS® Valves Only

16	H-633-AA	1" (25 mm) Sweat Solder Kit
	H-636-AA	¾" (19 mm) Sweat Solder Kit
17	H-700-A	1" (25 mm) Bak-Chek® Control Stop
	H-700-A	¾" (19 mm) Bak-Chek® Control Stop
18	H-1010-A	Vandal Resistant Stop Cap
19	EBV-36-A	Valve Body
20A	V-600-AA	1½" (38 mm) x 10½" (229 mm) Vacuum Breaker (Model 8110 and 8111)
	V-600-AA	1½" (38 mm) x 15" (584 mm) Vacuum Breaker (Model 8113)
	V-600-AA	1½" (38 mm) x 23" (584 mm) Vacuum Breaker (Model 8115)
	V-600-AA	1½" (38 mm) x 26" (660 mm) Vacuum Breaker (Model 8116)
20B	V-600-A	3" (76 mm) Vacuum Breaker Assembly
20C	V-600-AA	1¼" (32 mm) x 10½" (229 mm) Vacuum Breaker (Model 8180)
20D	V-600-AA	¾" (19 mm) x 10½" (229 mm) Vacuum Breaker (Model 8186)
21	F-109	1½" (38 mm) Elbow Flush Connection
22A	F-5-AT	1½" Spud Coupling Assembly (Models 8110, 8110 8115 & 8116)
22B	F-5-AU	1¼" Spud Coupling Assembly (Model 8180)
22C	F-5-AW	¾" Spud Coupling Assembly (Model 8186)

Manufactured in the U.S.A. by Sloan Valve Company under one or more of the following patents: U.S. Patents: D598,975; D599,436; 7,124,997; 4,893,039; 5,169,118; 5,244,179; 5,295,655; Des. 345,113; Des. 355,478. Other Patents Pending. BAK-CHEK®, PARA-FLO®, PERMEX®, TURBO-FLO®.

This Installation Instructions and the Optima Plus Repair and Maintenance Guide are available at:  
[www.sloanvalve.com](http://www.sloanvalve.com)

The information contained in this document is subject to change without notice.

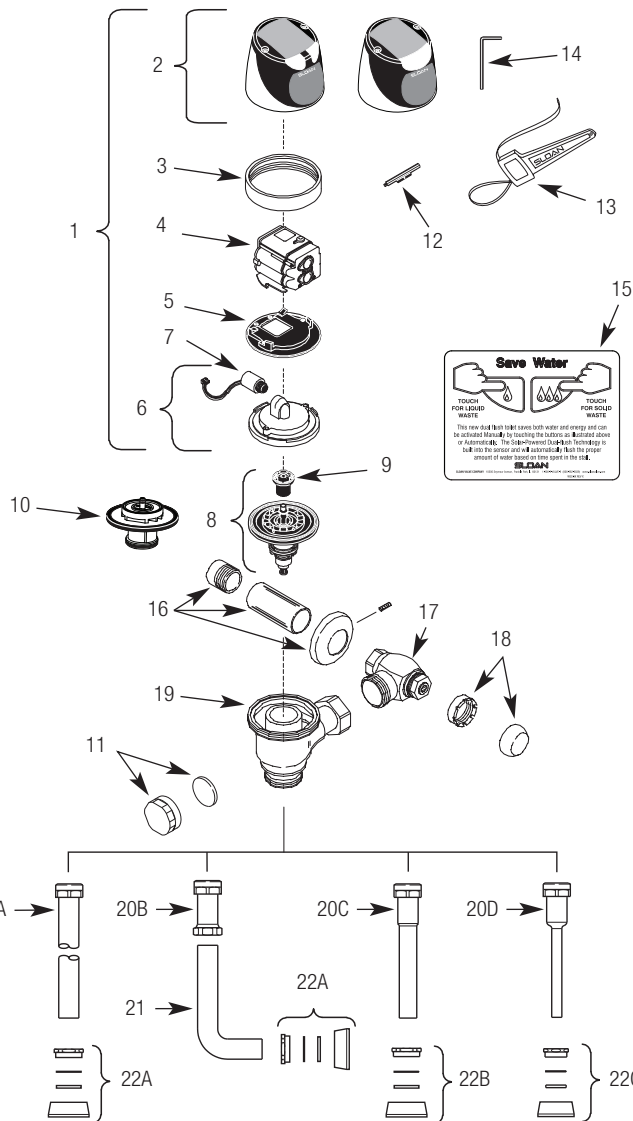

## FLEX TUBE DIAPHRAGM KIT SELECTION GUIDE

Flush Volume and Fixture	Item No. 8 Flex Tube Diaphragm Kit No.	Item No. 9 Flush Volume Regulator Part No.	Regulator Color
0.5 gpf/1.9 Lpf Urinal	EBV-1023-A	EBV-95	Green
1.6 gpf/6.0 Lpf Closet	EBV-1020-A	EBV-95	Green
1.28 gpf/4.7 Lpf Closet	EBV-1024-A	EBV-95	Green
1.5 gpf/5.7 Lpf Urinal	EBV-1022-A	EBV-102-2	Black
1.0 gpf/3.8 Lpf Urinal	EBV-1022-A	EBV-95	Green

The EBV-1020-A and EBV-1022-A Kits are supplied with multiple Flush Volume Regulators. The installer must use the correct Regulator when installing the kit.



## FLEX TUBE DIAPHRAGM ASSEMBLY

Sloan SOLIS® Valve Models Feature Sloan's Exclusive Flex Tube Diaphragm™ for the ultimate in valve performance, reliability and chloramines resistance.

## CARTRIDGE ASSEMBLY FOR MODELS 8186-0.13 AND 8186-0.25

# SLOAN®

SLOAN VALVE COMPANY • 10500 Seymour Avenue • Franklin Park, IL 60131  
 Phone: 1-800-982-5839 or 1-847-671-4300 • Fax: 1-800-447-8329 or 1-847-671-4380  
[www.sloanvalve.com](http://www.sloanvalve.com)

Copyright © 2010 SLOAN VALVE COMPANY

Code No. 0816805 - Rev. 1 (07/09)