

- EN** Installation / Warranty
- FR** Instructions de montage / Garantie
- ES** Instrucciones de montaje / Garantía

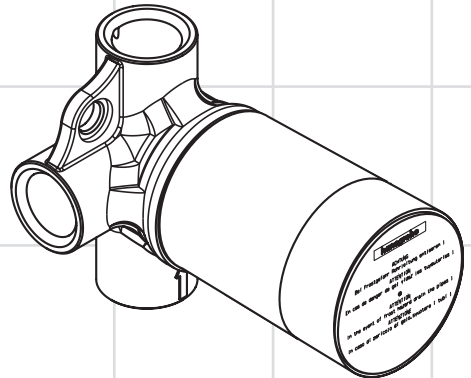

**Trio with Shut-Off**  
15981181

## English

### Technical Information

Recommended water pressure	15 - 75 PSI
Max. water pressure	145 PSI
Recommended hot water temp.	120° - 140° F*
Max. hot water temp	176° F*
Flow rate	17 GPM
Connections	¾ NPT

\*Please know and follow all applicable local plumbing codes when setting the temperature on the water heater.

### Installation Considerations

- For best results, Hansgrohe recommends that this unit be installed by a licensed, professional plumber.
- Please read over these instructions thoroughly before beginning installation. Make sure that you have all tools and supplies needed to complete the installation.
- Trio with Shut-Off #15981181 has an "off" position.
- **Do not use Trio with Shut-Off #15981181 in combination with a pressure balance valve or with another valve that has an "off" position.**
- To prevent scald injury, the maximum output temperature of the shower mixing valve must be no higher than 120°F. In Massachusetts, the maximum output temperature can be no higher than 112°F.
- Keep this booklet and the receipt (or other proof of date and place of purchase) for this product in a safe place. The receipt is required should it be necessary to request warranty parts.

## Français

### Données techniques

Pression d'eau recommandée	15 - 75 PSI
Pression d'eau maximum	145 PSI
Température recommandée d'eau chaude	120° - 140° F*
Température maximum d'eau chaude	176° F*
Capacité nominale	17 GPM
Raccordements	¾ NPT

\* Vous devez connaître et respecter tous les codes de plomberie locaux applicables pour le réglage de la température du chauffe-eau.

### À prendre en considération pour l'installation

- Pour de meilleurs résultats, Hansgrohe recommande que ce produit soit installé par un plombier professionnel licencié.
- Veuillez lire attentivement ces instructions avant de procéder à l'installation. Assurez-vous de disposer de tous les outils et du matériel nécessaires pour l'installation.
- L'inverseur Trio 15981181 est muni d'une position d'arrêt (« off »).
- **Ne pas utiliser un inverseur Trio 15981181 en combinaison avec un robinet à régulateur de pression ou avec un autre robinet muni de la position d'arrêt « off ».**
- Pour empêcher des blessures par ébullition, la température de sortie maximale du robinet de douche ne doit pas excéder 120°F. Au Massachusetts, la température de sortie maximale du robinet de douche ne doit pas excéder 112°F.
- Conservez ce livret et le reçu (ou une autre preuve sur laquelle figurent la date et l'endroit de l'achat) pour ce produit dans un endroit sûr. Le reçu est requis si vous commandez des pièces sous garantie.

## Suggested Installation

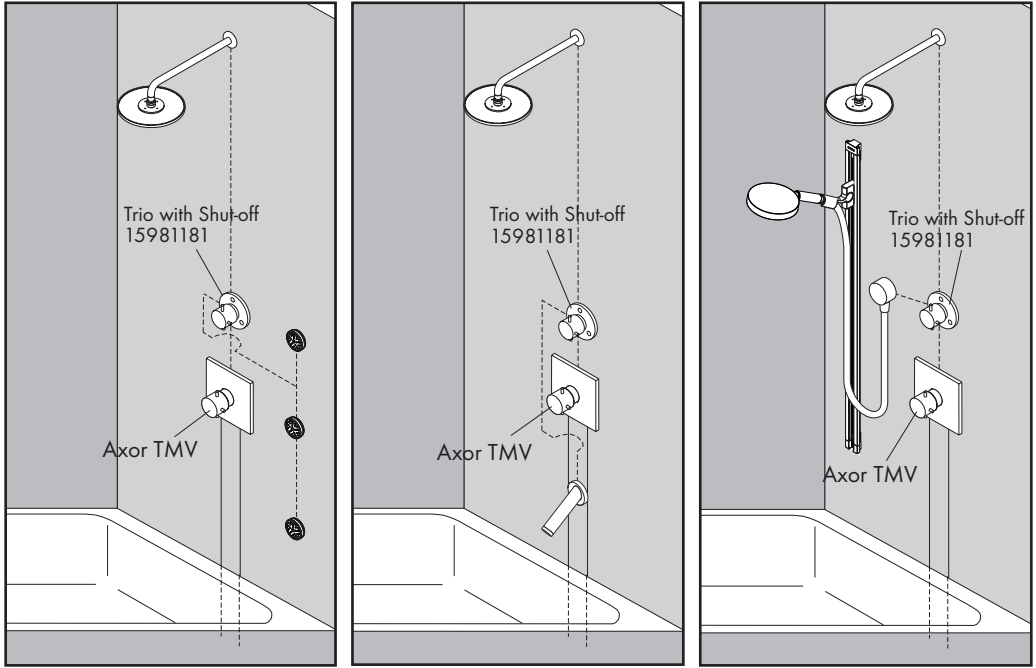

Two-function installations using the Axor thermostatic mixing valve (TMV)

These are not the only possible installations. If you have questions regarding a specific installation, please contact Hansgrohe Customer Service.

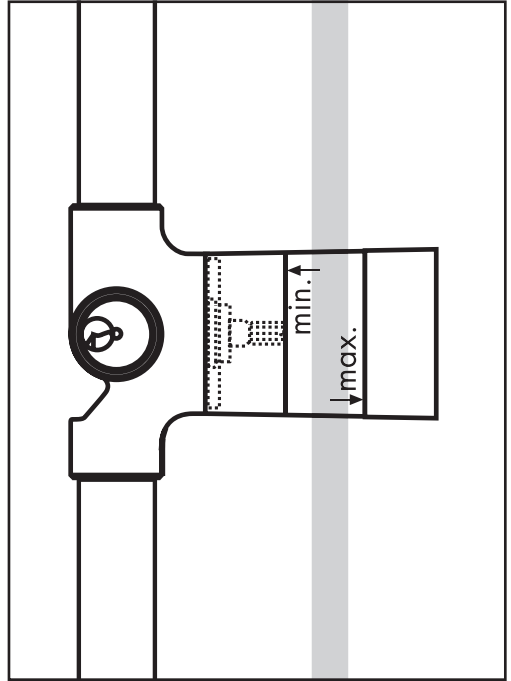
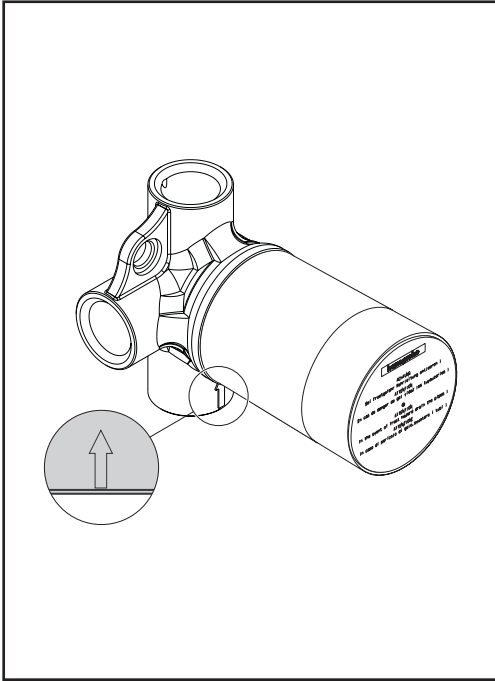

Les exemples illustrés ici ne représentent pas les seules installations possibles. Si vous désirez poser des questions sur une installation particulière, veuillez communiquer avec l'assistance technique de Hansgrohe.

Éstas no son las únicas instalaciones posibles. Si tiene preguntas relativas a una instalación específica, comuníquese con el Servicio al Cliente de Hansgrohe.



## English



Flush the lines thoroughly before installing the valve. Damage to the cartridge caused by debris is not covered under the Hansgrohe USA warranty.

-  **An arrow showing the direction of the water flow is cast into the valve body.**
-  **The water must flow through the valve in that direction or damage to the cartridge will occur.**

Install the valve so that the outside surface of the **finished** wall falls between the "minimum" and "maximum" lines marked on the plaster shield.

## Français



Rincez abondamment les conduites avant d'installer la valve. La garantie É.-U. Hansgrohe ne couvre pas les dommages causés aux cartouches par les dépôts ou impuretés.

-  **Une flèche indiquant la direction du débit figure sur le corps de la valve.**
-  **Si l'eau ne coule pas dans la valve dans cette direction, la cartouche sera endommagée.**

Installez la valve de façon à ce que la surface extérieure du mur fini tombe entre les lignes « minimum » et « maximum » figurant sur le protecteur de plâtre.

## Español

Lave a fondo las tuberías antes de instalar la válvula. Los daños al cartucho causados por los desechos no están cubiertos por la garantía de Hansgrohe para EE.UU.

-  **En el cuerpo de la válvula está fundida una flecha que muestra el sentido del flujo de agua.**
-  **El agua debe circular por la válvula en ese sentido, puesto que de lo contrario puede dañarse el cartucho.**

Instale la válvula de modo que la superficie exterior de la pared terminada quede entre las líneas "min" y "max" marcadas en el protector de yeso.

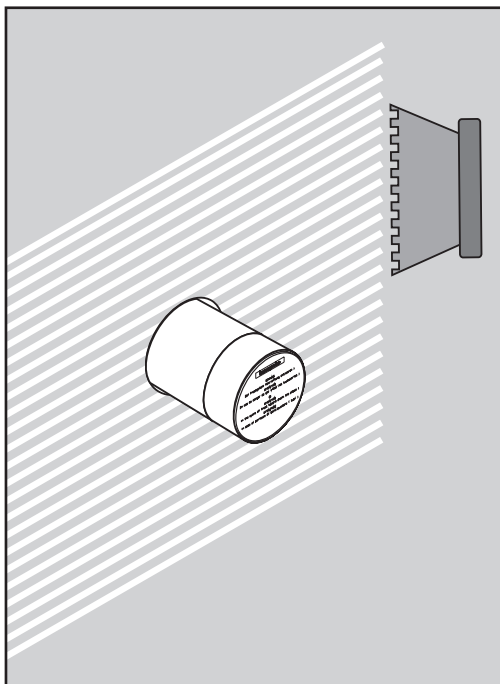
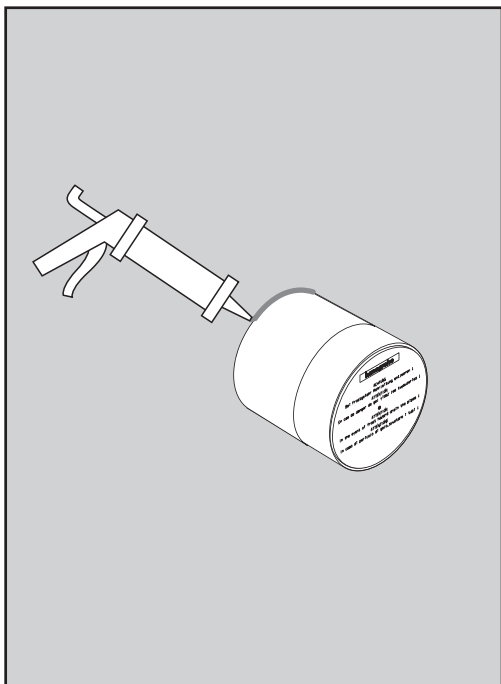

## English

-  **Do not remove the plaster shield from the valve.**

When the drywall or green board is installed, **seal the opening around the Trio with waterproof sealant.**

-  **Failure to seal the opening may result in water damage.**

Apply adhesive (not included) to the wall around the valve.

-  **Do not use hot glue as it will damage the gasket.**

## Français

-  **Ne retirez pas le protecteur de plâtre de la valve.**

Une fois la cloison sèche ou la céramique installée, scellez l'ouverture autour de l'inverseur Trio à l'aide d'un agent d'étanchéité.

-  **Si l'ouverture n'est pas scellée, l'eau pourrait éventuellement causer des dommages.**

Appliquez un adhésif (non compris) sur le mur autour de la valve.

-  **N'utilisez pas de colle chaude car vous pourriez endommager le joint.**

## Español

-  **No retire el protector de yeso de la válvula.**

Cuando se instale la tabla roca o panel verde, selle la abertura alrededor del Trio con un sellador impermeable.

-  **Si la abertura no se sella, pueden producirse daños por acción del agua.**

Aplique adhesivo (no incluido) a la pared alrededor de la válvula.

-  **No use cola caliente, puesto que daña la junta.**

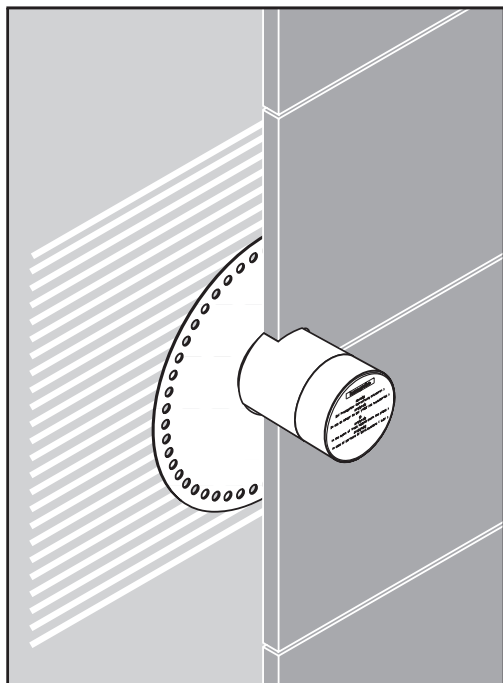

## English

Install the gasket over the Trio.

Install the finished wall material (tile, etc.) over the gasket.

If the outside surface of the finished wall extends beyond the "maximum" marking on the plaster shield, order extension 96370000 through your Hansgrohe dealer.

## Français

Installez le joint sur l'inverseur Trio.

Installez le matériel de finition du mur (carreaux, etc.) par-dessus le joint.

Si la surface extérieure du mur fini va au-delà de la marque « maximum » du protecteur de plâtre, commandez une rallonge 96370000 auprès de votre détaillant Hansgrohe.

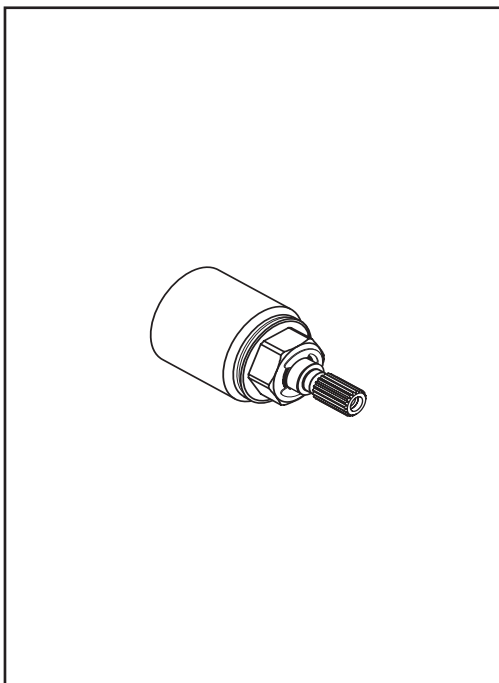

## Español

Instale la junta sobre el Trio.

Instale el material de la pared terminada (azulejo, etc.) sobre la junta.

Si la superficie exterior de la pared terminada se extiende más allá de la marca de "máximo" del protector de yeso, solicite la extensión 96370000 al concesionario de Hansgrohe.

# Limited Consumer Warranty

---

This product has been manufactured and tested to the highest quality standards by Hansgrohe, Inc. ("Hansgrohe"). This warranty is limited to Hansgrohe products that are purchased by a consumer in the United States or Canada after March 1, 1996, and installed in either the United States or in Canada.

## WHO IS COVERED BY THE WARRANTY

This warranty extends to the original purchaser only. This warranty is non-transferable.

## WHAT IS COVERED BY THE WARRANTY

The warranty covers only your Hansgrohe manufactured product. Hansgrohe warrants this product against defects in material or workmanship as follows:

Hansgrohe will replace at no charge for parts only or, at its option, replace any product or part of the product that proves defective because of improper workmanship and/or material, under normal installation, use, service and maintenance. If Hansgrohe is unable to provide a replacement and repair is not practical or cannot be made in timely fashion, Hansgrohe may elect to refund the purchase price in exchange for the return of the product.

## LENGTH OF WARRANTY

Replacement or repaired parts of products will be covered for the term of this warranty, as stated in the following two sentences. If you are a consumer who purchased the product for use primarily for personal, family or household purposes, this warranty extends for as long as you own the product and the home in which the product is originally installed. If you purchased the product for use primarily for any other purpose, including, without limitation, a commercial purpose, this warranty extends only (i) for 1 year, with respect to Hansgrohe & Commercial products, and (ii) for 5 years, with respect to Axor products.

## THIS WARRANTY DOES NOT COVER, AND HANSGROHE WILL NOT PAY FOR:

- A. Conditions, malfunctions or damage not resulting from defects in material or workmanship.
- B. Conditions, malfunctions or damage resulting from
  - (1) normal wear and tear, improper installation, improper maintenance, misuse, abuse, negligence, accident or alteration;
  - (2) the use of abrasive or caustic cleaning agents or "no-rinse" cleaning products, or the use of the product in any manner contrary to the product instructions; or
  - (3) conditions in the home such as excessive water pressure or corrosion.
- C. Labor and other expenses for disconnection, deinstallation, or return of the product for warranty service (including but not limited to proper packaging and shipping costs), or for installation or reinstallation of the product.
- D. Accessories, connected materials and products, or related products not manufactured by Hansgrohe.
- E. Any Hansgrohe or Axor product sold for display purposes.
- F. Hansgrohe Water Filtration System is subject to a 1-year limited warranty. Warranty does not include replacement filters.

## TO OBTAIN WARRANTY PARTS OR INFORMATION

Contact your Hansgrohe retailer, or contact Technical Service at:

Hansgrohe, Inc.  
1492 Bluegrass Lakes Parkway  
Alpharetta, GA 30004  
Toll-free 800-334-0455

In requesting warranty service, you will need to provide:

- 1. The sales receipt or other evidence of the date and place of purchase.
- 2. A description of the problem.
- 3. Delivery of the product or the defective part, postage prepaid and carefully packed and insured, to:

Hansgrohe, Inc.  
1492 Bluegrass Lakes Parkway  
Alpharetta, GA 30004  
Toll-free 800-334-0455

When warranty service is completed, any repaired or replacement product or part will be returned to you postage prepaid.

---

## Exclusions and Limitations

**REPAIR OR REPLACEMENT (OR, IN LIMITED CIRCUMSTANCES, REFUND OF THE PURCHASE PRICE) AS PROVIDED UNDER THIS WARRANTY IS THE EXCLUSIVE REMEDY OF THE PURCHASER. HANSGROHE NEITHER ASSUMES NOR AUTHORIZES ANY PERSON TO CREATE FOR IT ANY OTHER OBLIGATION OR LIABILITY IN CONNECTION WITH THIS PRODUCT.**

**HANSGROHE SHALL NOT BE LIABLE TO PURCHASER OR ANY OTHER PERSON FOR ANY INCIDENTAL, SPECIAL OR CONSEQUENTIAL DAMAGES, ARISING OUT OF BREACH OF THIS WARRANTY OR ANY IMPLIED WARRANTY (INCLUDING BUT NOT LIMITED TO ANY IMPLIED WARRANTY OF MERCHANTABILITY).**

Some States do not allow the exclusion or limitation of incidental or consequential damages, so the above limitation or exclusion may not apply to you. This warranty gives you specific legal rights, and you may also have other rights that vary from state to state.

**TO THE EXTENT PERMITTED BY LAW, ANY IMPLIED WARRANTIES OF MERCHANTABILITY AND FITNESS FOR A PARTICULAR PURPOSE, ARE LIMITED TO THE DURATION OF THE EXPRESS WARRANTY.**

Some states do not allow limitations on how long an implied warranty may last, so the above limitations may not apply to you.

You may be required by law to give us a reasonable opportunity to correct or cure any failure to comply before you can bring any action in court against us under the Magnuson-Moss Warranty Act.

### **PRODUCT INSTRUCTIONS AND QUESTIONS**

Upon purchase or prior to installation, please carefully inspect your Hansgrohe product for any damage or visible defect. Prior to installing, always carefully study the enclosed instructions on the proper installation and the care and maintenance of this product. If you have questions at any time about the use, installation or performance of your Hansgrohe product, or this warranty, please write us or call us toll-free at 800-334-0455.