

Nitro Valves

Nitro installation instructions.....

Nitro performance information.....

<p>N-100</p>  A schematic diagram of the N-100 valve, showing a solenoid coil on top, a central valve body with three ports, and a large threaded inlet on the left.	<p>N-100S</p>  A schematic diagram of the N-100S valve, similar to the N-100 but with a different inlet configuration.	<p>N-100SF</p>  A schematic diagram of the N-100SF valve, featuring a solenoid coil with a manual override handle on top.
<p>N-100F</p>  A schematic diagram of the N-100F valve, similar to the N-100SF but with a different inlet configuration.	<p>N-100MB</p>  A schematic diagram of the N-100MB valve, featuring a solenoid coil on top and a large threaded inlet on the left.	<p>N-100MBF</p>  A schematic diagram of the N-100MBF valve, similar to the N-100MB but with a different inlet configuration.

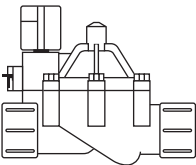
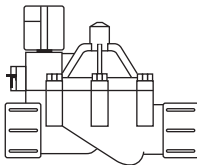
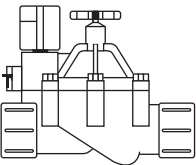
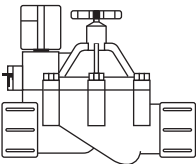
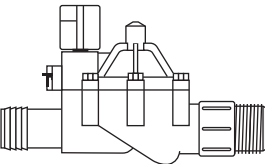
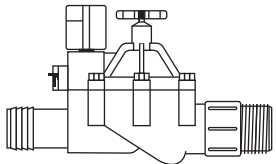

NITRO PERFORMANCE INFORMATION

Models

N-100 (1 in. FIP)*

N-100F (1 in. FIP with flow)*

N-100S (1 in. SLIPxSLIP)

N-100SF (1 in. SLIPxSLIP with flow)

N-100MB (1 in. Male x Barb)

N-100MBF (1 in. Male x Barb with flow)

*International specify-ISO

Features

- Engineering grade PVC body and cover with combination hex, slot, and Phillips retaining screws
- Non-rising flow control stem throttles all valves from full open to closed position on all flow control models
- Molded shock cone reduces effects of water hammer
- Nitro series is a normally closed type valve
- The diaphragm's dual self cleaning ports constantly flex, inhibiting sand and silt from blocking valve action; no filters or strainers required
- The unique "reverse flow" porting design permits equal pressure distribution on both sides of the diaphragm, regardless of line pressure providing zero stress to prevent "stretching" a common cause of valve failure
- High efficiency M24E solenoid with stainless steel actuator designed by Weathermatic permits longer wire runs
- Easy access internal bleed lever has stops for open and closed positions and requires no tools for manual operation
- 150 psi (10,3) bar rating

Electrical

24VAC/60 Hz

Inrush: 9.77VA

Holding: 6.2VA

See catalog wire sizing chart



NITRO VALVE TROUBLESHOOTING

Problem	Solution
Valve will not open manually	Check water supply and any possible master or gate valves to insure they are open.
	Check that valve is installed with the arrow pointing in the downstream direction.
	Check that the flow control is fully open (counterclockwise).
	Turn off the water supply. Remove the solenoid and check for debris blocking the exhaust port.
	Turn off the water supply. Remove the cover. Inspect the diaphragm for damage and replace if necessary.
Valve will not open electrically	Check voltage at controller for 24 VAC to station.
	Check voltage across the solenoid lead wires for minimum 21 VAC.
	If the valve still does not operate electrically replace the solenoid with a Weathermatic model M24E solenoid.
Valve will not close	Insure the manual bleed lever is in the closed position.
	Check for leaks around flow control, solenoid or between valve cover and body.
	Turn off the water supply. Remove the solenoid and check for debris or damage to the exhaust port.
	Turn off the water supply. Remove valve cover and inspect for debris under diaphragm or debris in diaphragm ports
Slow leak through sprinklers	Check for dirt or gravel embedded in diaphragm seat.
	Check actuator and exhaust fitting for proper seating.



NITRO VALVE INSTALLATION AND OPERATION

Important: Flush the supply lines completely before installing valves.

- A.** For threaded models wrap male adapters with 2 wraps of Teflon tape and thread the adapters into the valve inlet and outlet 1 turn past hand tight. **CAUTION:** Over tightening may cause damage to the valve.
- B.** For slip models apply a thin coating of solvent cement to the outside of the supply line and the valve inlet. Twist the valve fully onto the supply line to evenly spread the cement. Repeat these steps for the outlet connection. The solenoid must be on the downstream side of the connection.
- C.** For barbed models slip one or two clamps over the poly pipe. Slip the poly pipe completely over the barbed outlet. Clamp the poly pipe securely to the barb.
- D.** Using watertight connectors, connect the valve common and an individual station wire to the solenoid leads.
- E.** Flush the laterals by opening the internal manual bleed lever on the downstream side of the solenoid. Turn the flow control stem fully open (counterclockwise) for flow control models.
- F.** Close the internal manual bleed after flushing the system.

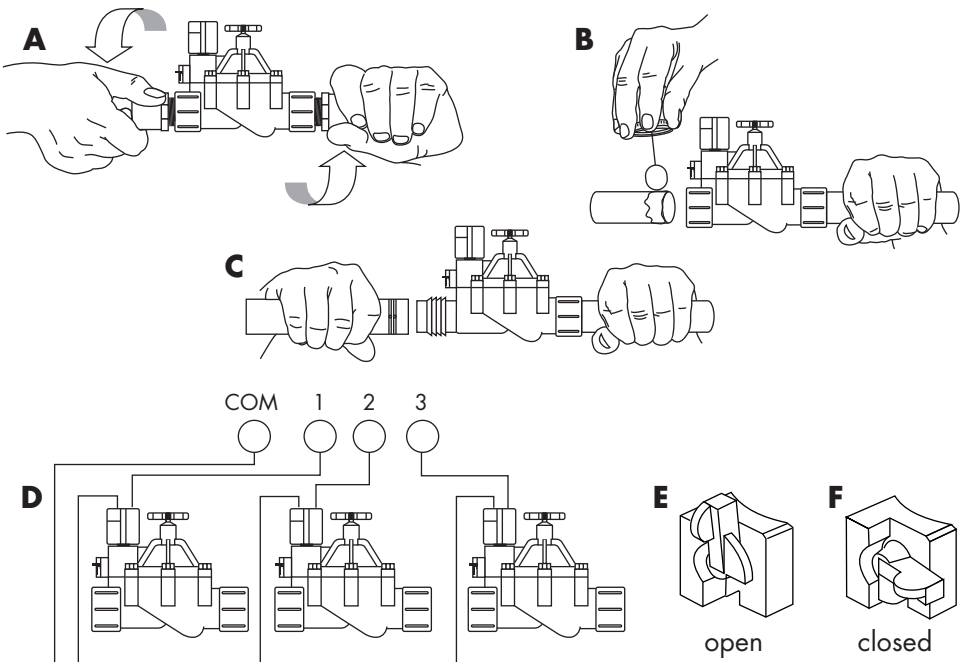



N-100MB



N-100



N-100S



Flow gpm	Loss psi	Metric	
		Flow m ³ /hr	Loss bar
0-4	1.2 Max.	0-1.0	0.09 Max.
4	1.2	1.0	0.09
6	1.7	1.5	0.14
8	2.5	2.0	0.19
10	3.0	2.5	0.22
12	3.4	3.0	0.25
14	3.8	3.5	0.28
16	4.1	4.0	0.30
18	4.4	4.5	0.32
20	4.6	5.0	0.33
22	4.8	5.5	0.35
24	5.1	6.0	0.38
26	5.4	6.5	0.41
28	5.8	7.0	0.45
30	6.3	7.5	0.47
32	6.6	8.0	0.50
35	7.3		

N-100F



N-100SF



N-100MBF



IRRIGATION-MART

we SAVVY irrigation

800-SAY-RAIN | www.irrigation-mart.com

200 South Service Road East | Ruston, LA 71270-3442 | P: 318-255-1832 | F: 318-255-7572 | info@irrigation-mart.com

13799 Airline Highway | Baton Rouge, LA 70817-5924 | P: 225-755-3447 | F: 225-755-1240