



see what Delta can do™

102097

Valve Rough in & Valve Trim

Models
R99601, T999001 & T999003
MagnaFlow™

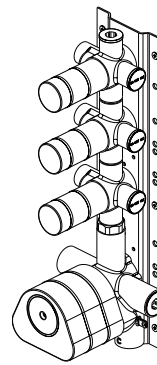

R99601

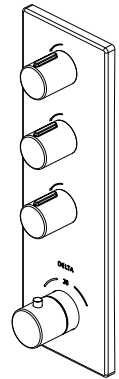

T999001

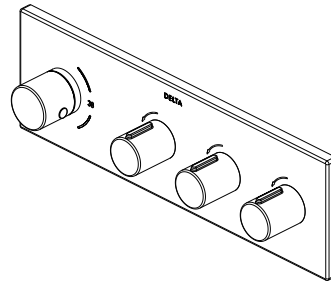

T999003

Write purchased model number here.

You may need:

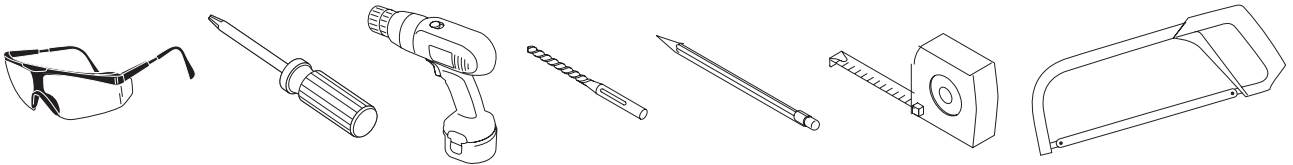

Vertical Installation - For use with T999001

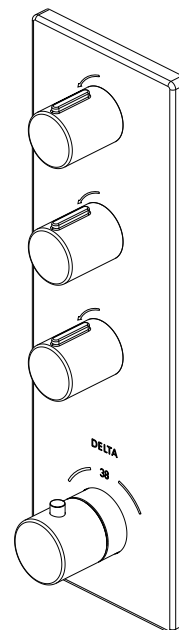
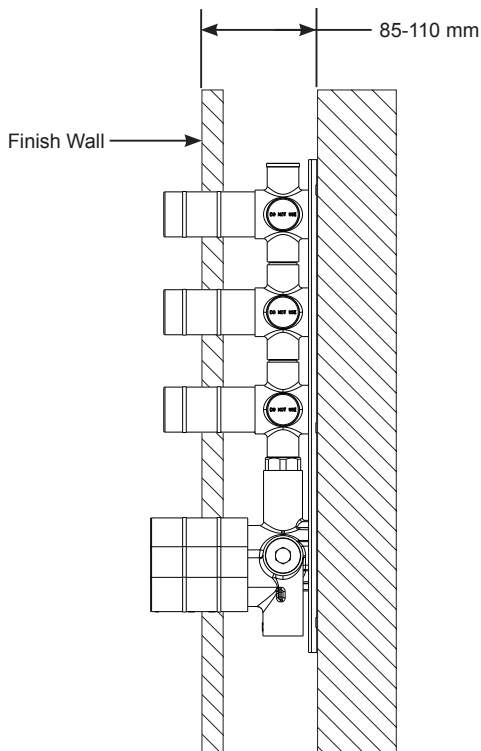

102097

Horizontal Installation - For use with T999003
NOTE: Instructions are for vertical installation.

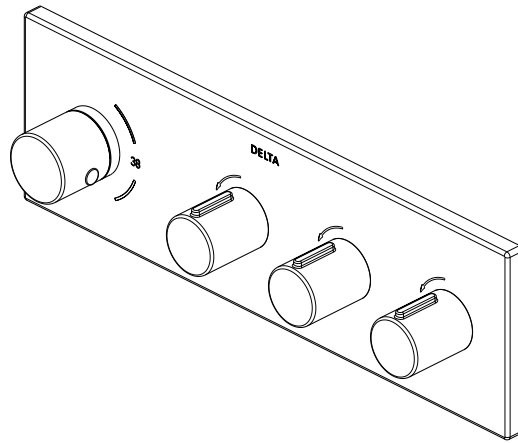
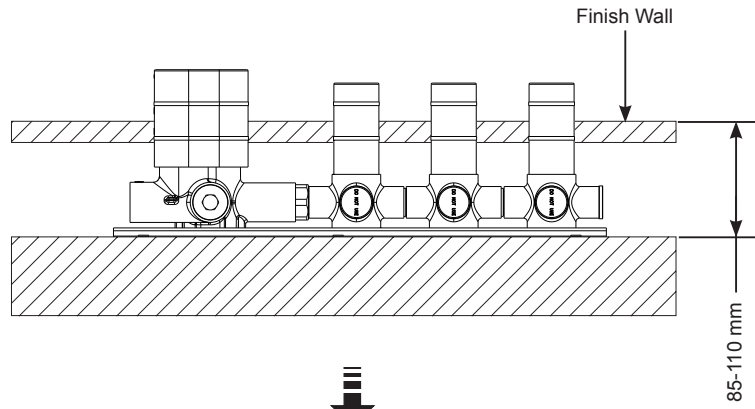

<p>1</p>	<p>2</p>
<p>Determine the position of drilling holes, mark the position by pencil.</p>	<p>Drill 6 holes on the marked position and install expansion screws.</p>

3

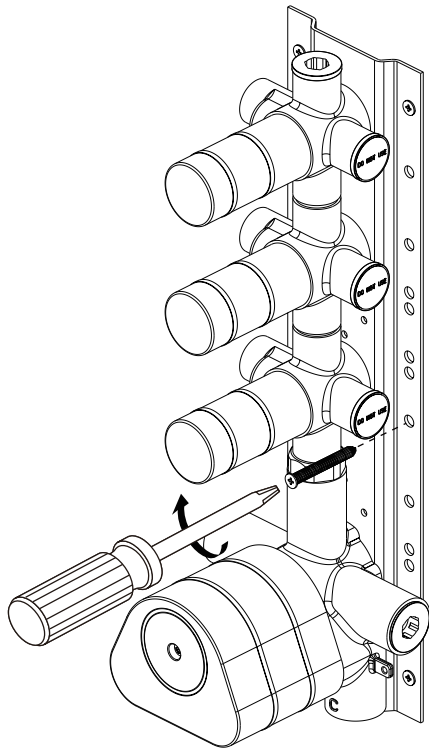

Secure the body against wall with 6 screws.

4

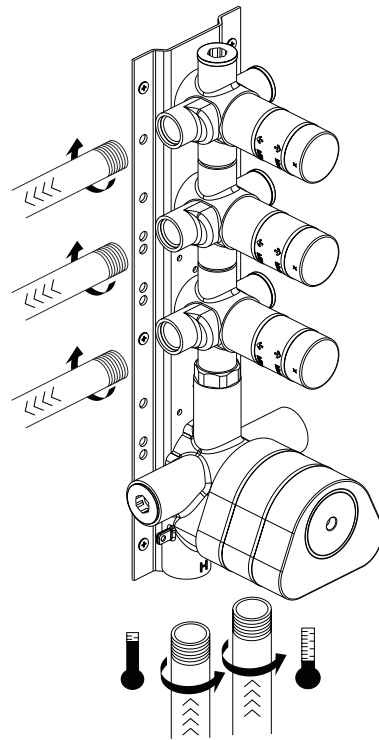

Install water inlet pipe and water outlet pipe

5

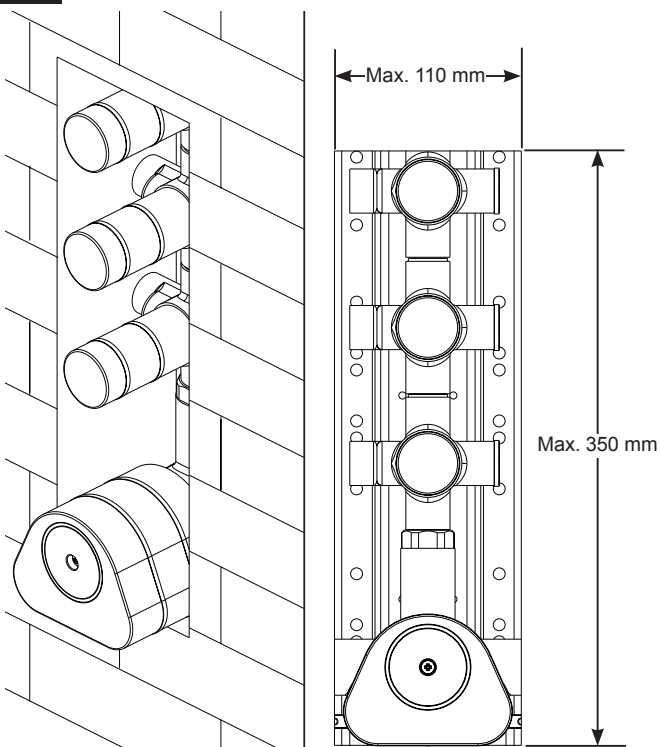

Complete finished wall.

6

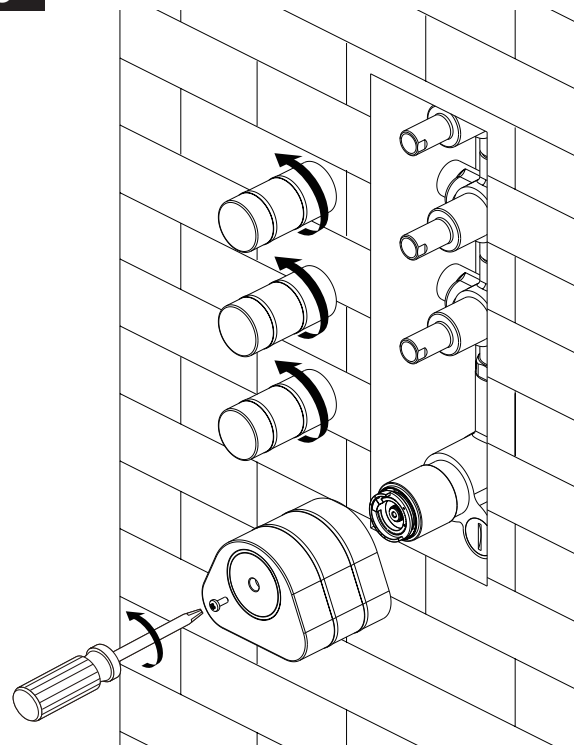

Remove and discard the plastic guards from the rough once the trim installation is ready to be completed.

7

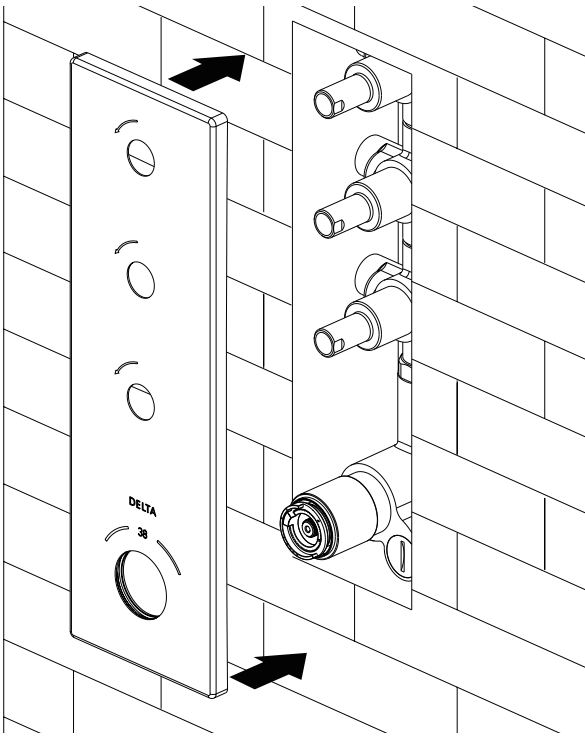

Place escutcheon onto the post.

8

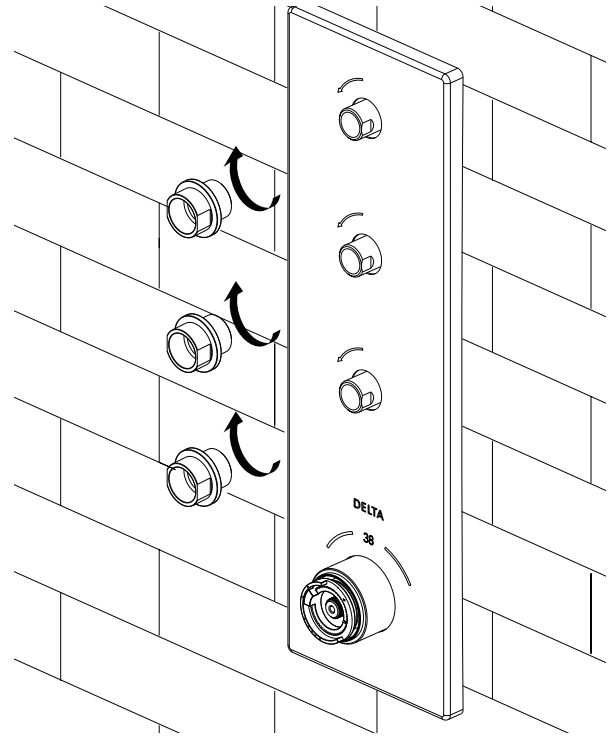

Install the adapter.

9

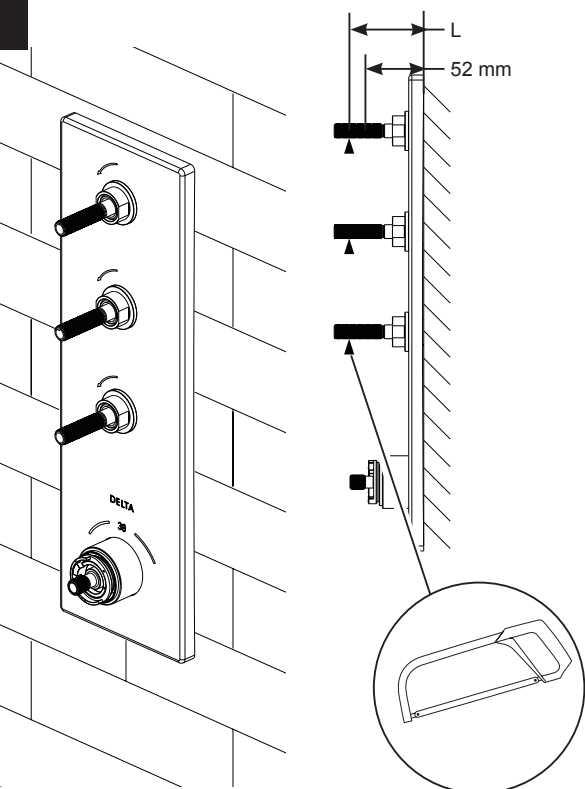

Cut through the extension at marked position with a saw when the length L is larger than 52 mm.

10

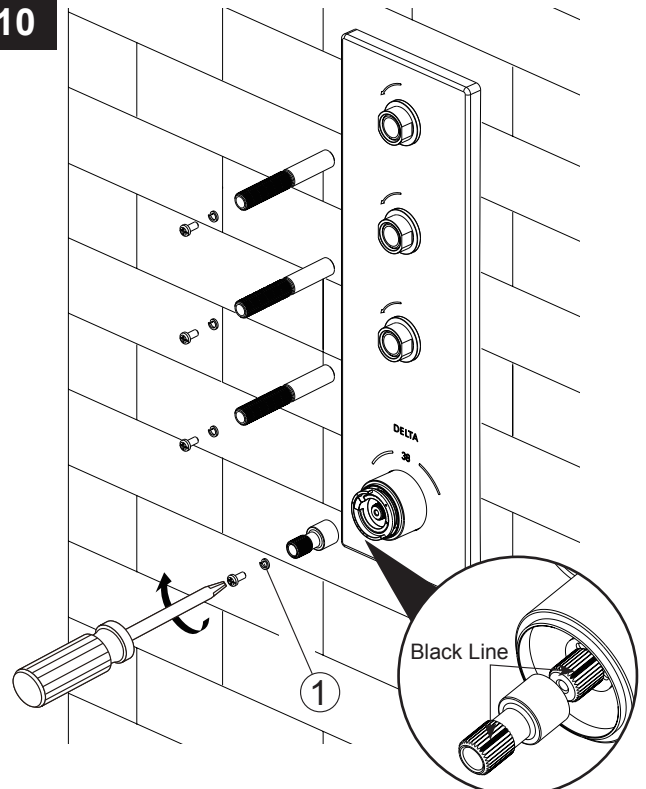

Ensure the black line on extension is aligned with the black line on cartridge before tightening screw.
Note: Ensure clip (1) is placed in the extension.

11

The Temperature Setting Check

NOTE: The thermostatic valve cartridge is calibrated at the factory for a shower temperature of approximately 38°C when the Black line in spline adapter is aligned with the "38" on the escutcheon.

1. Turn the water on
2. Position a thermometer in the water stream to check the shower temperature.
3. If the water temperature is less than 38°C or is more than 38°C, adjust the spline adapter till temperature is approximately 38°C (Tips: Allow the water to run for several minutes to stabilize the water supply temperature)
4. Install handle, ensure the button on handle is aligned with "38"

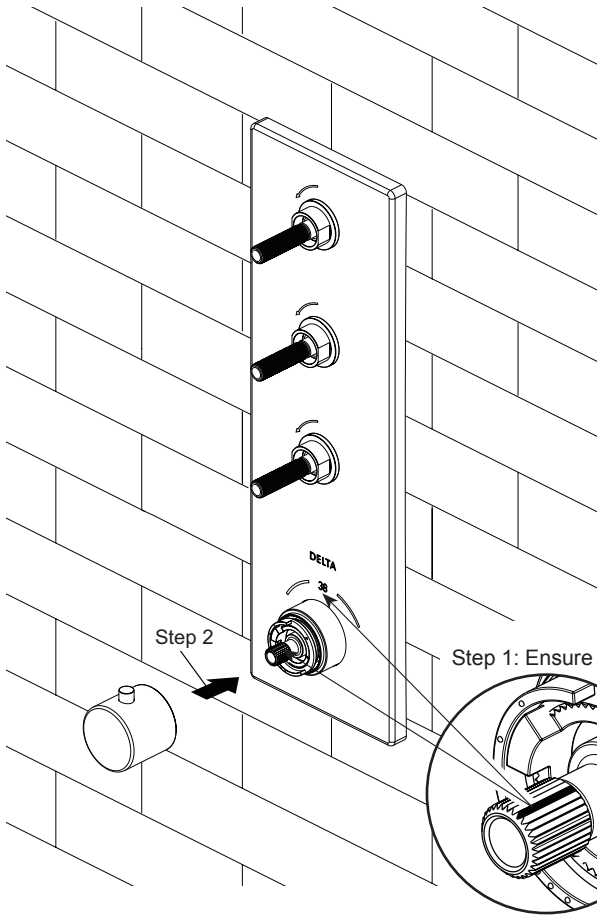

Step 2

Step 1: Ensure the black line is aligned with "38" on the escutcheon

12

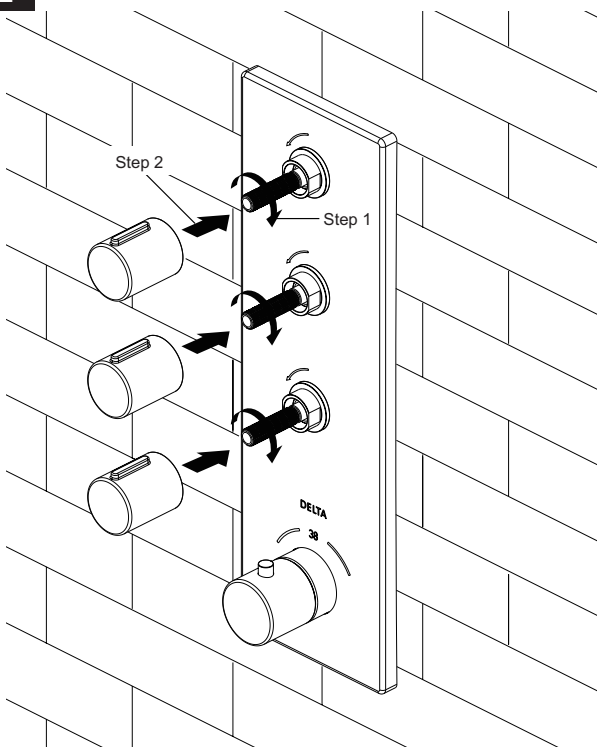

Step 2

Step 1

NOTE: Before installing the handle, rotate the extension spindle clockwise till it meets the limit. Only after this step, install the handle.

13

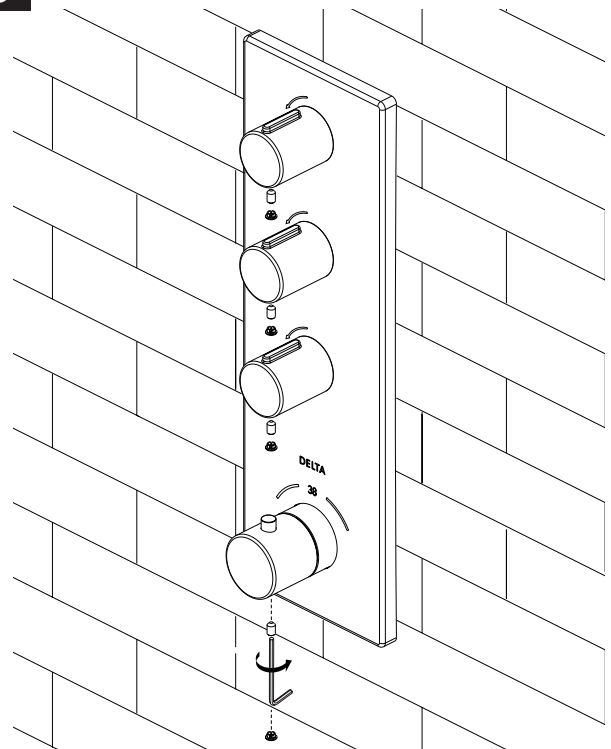

Secure handle with set screw, then install button.

Model
R99601

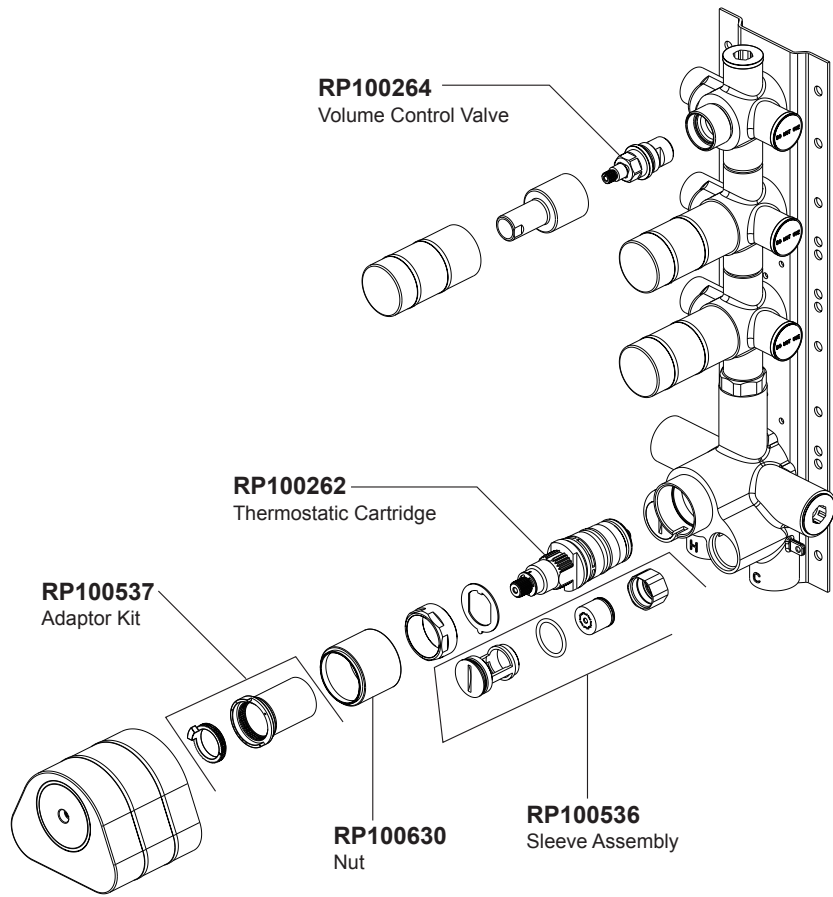

Model
T999001

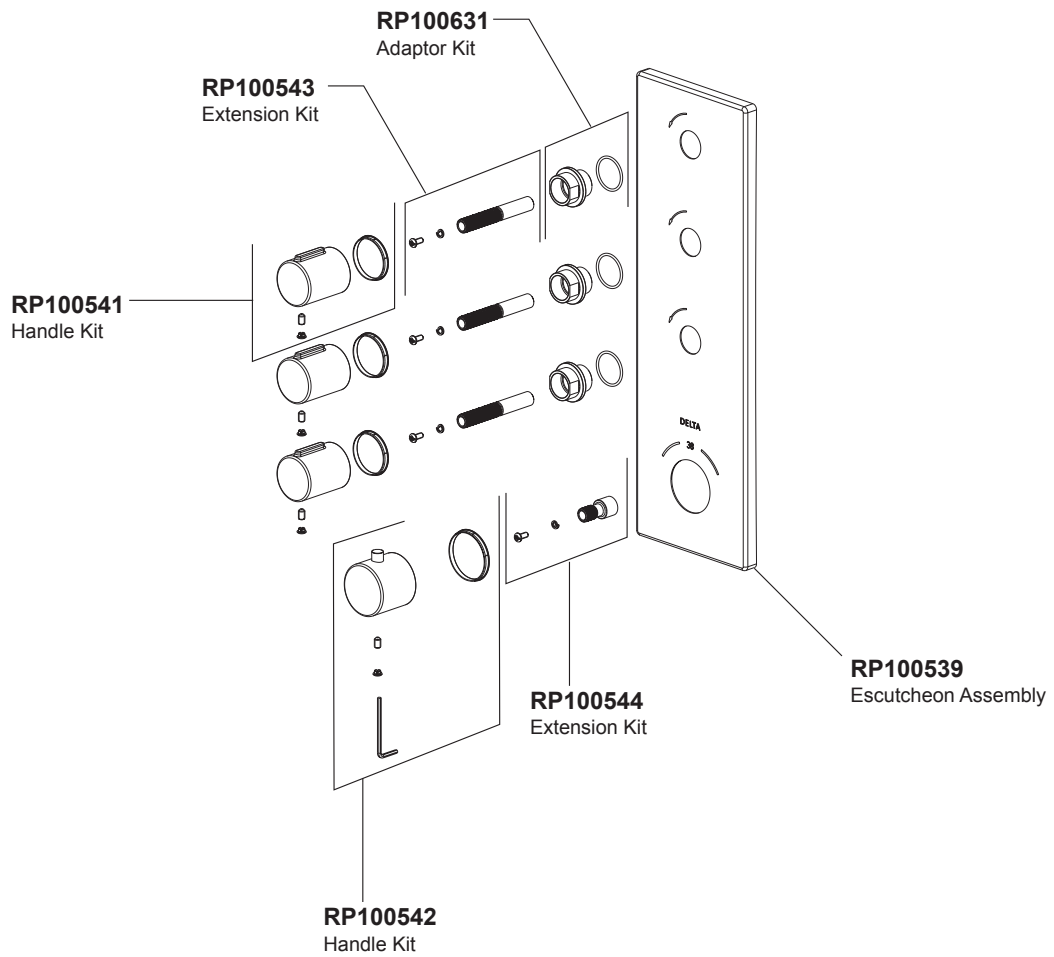

Model
T999003

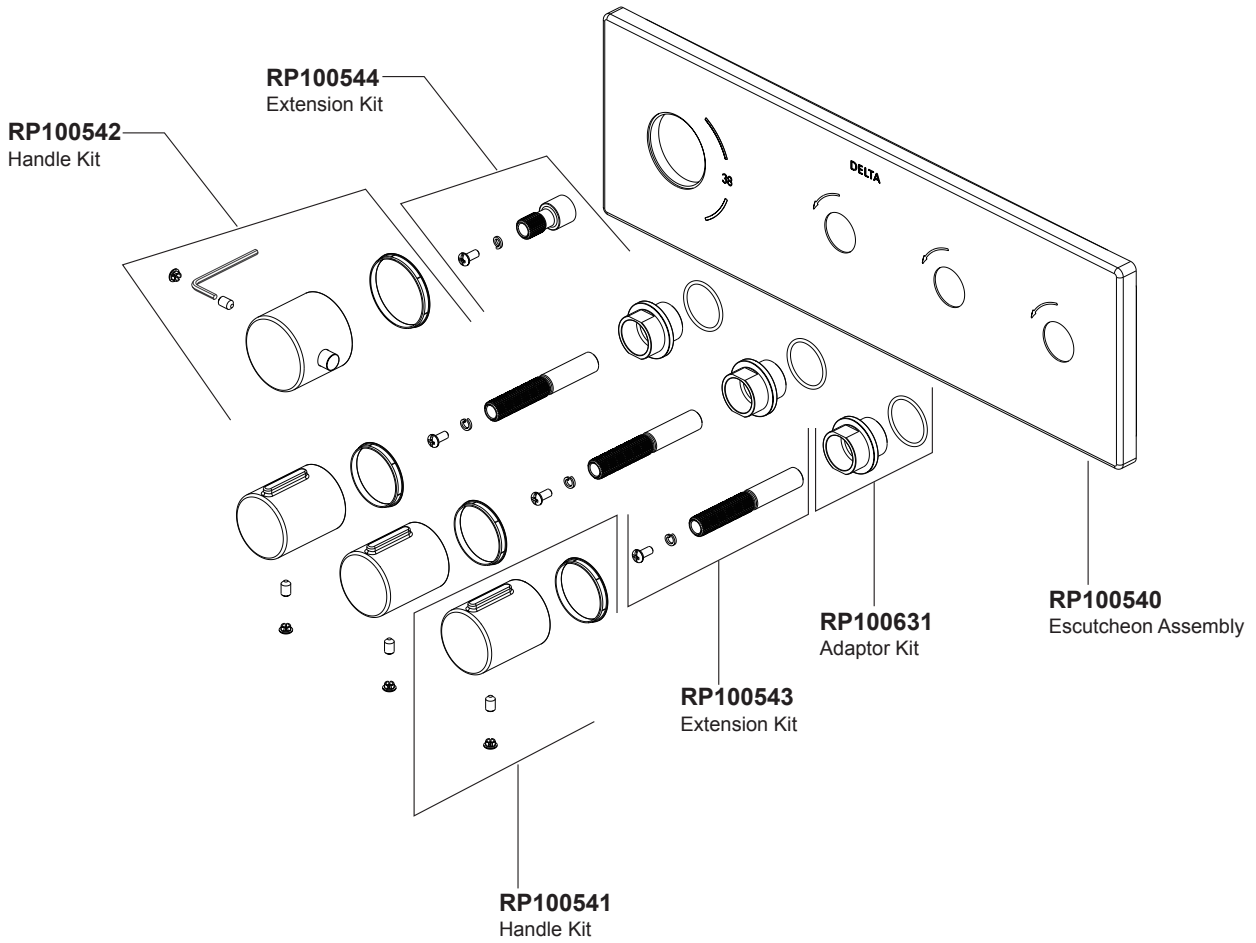

WARRANTY INFORMATION

Delta Faucet Company India Private Limited Limited Warranty on Delta® and Brizo® Residential Faucets, Showers, Hand Showers and Accessories and Delta® Commercial Products

PARTS AND FINISH (RESIDENTIAL PRODUCTS)

All parts (other than electronic parts and batteries, if any) and finishes of each Delta® or Brizo® residential faucet, shower, hand shower or accessory are warranted to the original consumer purchaser for normal residential usage to be free from defects in material and workmanship for a period of ten years from the date of purchase, and to commercial purchasers, for five years from the date of purchase.

ELECTRONIC PARTS AND BATTERIES (IF APPLICABLE) (RESIDENTIAL PRODUCTS)

Electronic parts (other than batteries), if any, of each Delta® or Brizo® residential faucet are warranted to the original consumer purchaser for normal residential usage to be free from defects in material and workmanship for one year from the date of purchase and to commercial purchasers, for one year from the date of purchase. No warranty is provided on batteries.

COMMERCIAL PRODUCTS

All parts and finishes of each Delta® commercial product are warranted to the original purchaser to be free from defects in material and workmanship for a period of five years from the date of purchase unless otherwise specifically stated in the catalog and/or price book.

Delta Faucet Company India Private Limited (Delta India) will repair or replace, during the applicable warranty period, any part or finish that proves defective in material and/or workmanship under normal installation, use and service. If repair or replacement is not practical, Delta India may elect to replace the product with a similar product of comparable value in exchange for the return of the product. For products installed or otherwise located within the municipal limits of any city in which Delta India has an authorized service location, Delta India will also bear the costs and expenses of travel, labor and installation charges incurred by such location's authorized service personnel in connection with the repair/service/replacement of the product in accordance with the warranty above. These are your exclusive remedies.

This Warranty does not cover hoses, rubber components and other consumables and will not be extended as a result of repair or replacement of the product.

Delta India recommends using a professional plumber for all installation and repair. We also recommend that you use only genuine Delta® or Brizo® replacement parts.

Delta India shall not be liable for, and this Warranty does not cover, any damage to the product resulting from (1) misuse, abuse, neglect or improper or incorrectly performed installation, maintenance or repair, (2) low or high water pressure or water impurities, or (3) failure to follow the applicable care and cleaning instructions, including the use of abrasive cleansers, ammonia, bleach, acids, alcohol or other products not recommended for use on chrome products. For products installed or otherwise located outside of the municipal limits of any city in which Delta India has an authorized service location, Delta India shall also not be liable for, and the customer shall bear, any and all costs and expenses that are incurred for repair/service/replacement of the product in accordance with the warranty above, including but not limited to (a) any travel, labor and installation charges by service personnel, and (b) any freight costs incurred for transportation (to and/or from Delta India) of damaged/defective and replacement products/parts/components.

Warranty service or replacement parts may be obtained by contacting your local distributor or Delta Faucet Company India Private Limited in writing or by email or phone as follows:

Delta Faucet Company India Private Limited
Unit No. 1061/1062, 10th Floor, Tower B1, Spaze IT Park, Sector 49
Sohna Road, Gurgaon 122018
customercareindia@deltafaucet.com
Customer Care Phone No. 0.81305.18936

Proof of purchase (original sales receipt and warranty copy with dealer signature) from the original purchaser along with the damaged product must be made available to Delta India for all warranty claims. This Warranty applies only to Delta® and Brizo® products sold in India directly by, or through authorized distributors of, Delta India.

EXCEPT AS OTHERWISE EXPRESSLY PROVIDED ABOVE, AND TO THE EXTENT PERMITTED BY APPLICABLE LAW, DELTA FAUCET COMPANY INDIA PRIVATE LIMITED SHALL NOT BE RESPONSIBLE FOR, AND THIS WARRANTY DOES NOT COVER, SPECIAL, INCIDENTAL OR CONSEQUENTIAL DAMAGES, INCLUDING LABOR AND REMOVAL/INSTALLATION COSTS. Some countries do not allow the exclusion or limitation of special, incidental or consequential damages, so these limitations and exclusions may not apply to you. This warranty gives you specific legal rights, and you may also have other rights which vary from country to country.

This is Delta Faucet Company India Private Limited's exclusive written warranty and the warranty is not transferable.

If you have any questions or concerns regarding our warranty, please write, email or phone us at the addresses or phone number above.