



see what Delta can do™

# MultiChoice® Valve Trim with Diverter Installation Instructions Owners Manual T24 Models

104437

Write purchased model number here.

## You May Need

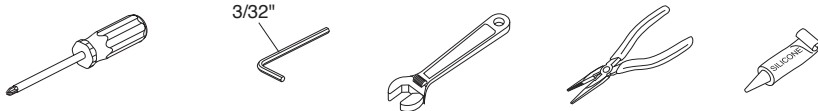

## Table of Contents:

|                                 |             |
|---------------------------------|-------------|
| Warranties .....                | Page 2      |
| Installation Instructions ..... | Pages 3 - 7 |
| Clean and care .....            | Page 8      |
| Maintenance .....               | Page 8      |

For additional replacement parts, visit [www.deltafaucet.com](http://www.deltafaucet.com)

**CAUTION:** This system/device must be set by the installer to ensure safe, maximum temperature. Any change in the setting may raise the discharge temperature above the limit considered safe and may lead to hot water burns.

**NOTICE TO INSTALLER: CAUTION!** – As the installer of this valve, it is your responsibility to properly **INSTALL** and **ADJUST** this valve per the instructions given. This valve does not automatically adjust for inlet temperature changes, therefore, someone must make the necessary Rotational Limit Stop adjustments at the time of installation and further adjustments may be necessary due to seasonal water temperature change. **YOU MUST** inform the owner/user of this requirement by following the instructions. If you or the owner/user are unsure how to properly make these adjustments please refer to page 5 and if still uncertain, call us at 1-800-345-DELTA.

After installation and adjustment, you must affix your name, company name and the date you adjusted the Rotational Limit Stop to the caution

label provided and apply or attach the label to the back side of the closest cabinet door and the warning label to the water heater. **Leave this Instruction Sheet for the owner's/user's reference.**

**WARNING:** This pressure balanced or thermostatic bath valve is designed to minimize the effects of outlet water temperature changes due to inlet pressure changes, commonly caused by dishwashers, washing machines, toilets and the like. It may not provide protection from hot water burns when there is a failure of other temperature controlling devices elsewhere in the plumbing system, if the rotational limit stop is not properly set or if the hot water temperature is changed after the settings are made or if the water inlet changes due to seasonal changes.

**WARNING:** Do not install a shut-off device on either outlet of this valve. When this type of device shuts off the water flow, it can defeat the ability of the valve to balance the hot and cold water pressures.

## Limited Warranty on Delta® Faucets

**Parts and Finish.** All parts (other than electronic parts and batteries) and finishes of this Delta® faucet are warranted to the original consumer purchaser to be free from defects in material and workmanship for as long as the original consumer purchaser owns the home in which the faucet was first installed. For commercial purchasers, the warranty period is ten (10) years for multi-family residential (apartments and condominiums) and five (5) years for all other commercial uses, in each case from the date of purchase.

**Electronic Parts and Batteries (if applicable).** Electronic parts (other than batteries), if any, of this Delta® faucet are warranted to the original consumer purchaser to be free from defects in material and workmanship for five (5) years from the date of purchase or, for commercial purchasers, for one (1) year from the date of purchase. No warranty is provided on batteries.

**What We Will Do.** Delta Faucet Company will repair or replace, free of charge, during the applicable warranty period (as described above), any part or finish that proves defective in material and/or workmanship under normal installation, use and service. If repair or replacement is not practical, Delta Faucet Company may elect to refund the purchase price in exchange for the return of the product. **These are your exclusive remedies.**

**What Is Not Covered.** Any labor charges incurred by the purchaser to repair, replace, install or remove this product are not covered by this warranty. Delta Faucet Company shall not be liable for any damage to the faucet resulting from reasonable wear and tear, outdoor use, misuse (including use of the product for an unintended application), freezing water, abuse, neglect or improper or incorrectly performed installation, maintenance or repair, including failure to follow the applicable care and cleaning instructions. Delta Faucet Company recommends using a professional plumber for all installation and repair of faucets. We also recommend that you use only genuine Delta® replacement parts.

**What You Must Do To Obtain Warranty Service or Replacement Parts.** A warranty claim may be made and replacement parts may be obtained by calling 1 800 345 DELTA (3358) or by contacting us by mail or online as follows (please include your model number and date of purchase):

**In the United States and Mexico:**

Delta Faucet Company  
Product Service  
55 E. 111th Street  
Indianapolis, IN 46280  
Attention: Customer Solutions  
[www.deltafaucet.com/service-parts/contact-us](http://www.deltafaucet.com/service-parts/contact-us)

**In Canada:**

Masco Canada Limited, Plumbing Group  
Technical Service Centre  
350 South Edgeware Road  
St. Thomas, Ontario, Canada N5P 4L1  
Attention: Customer Service  
<http://www.deltafaucet.ca/customersupport/assistance.html>

Proof of purchase (original sales receipt) from the original purchaser must be made available to Delta Faucet Company for all warranty claims unless the purchaser has registered the product with Delta Faucet Company. This warranty applies only to Delta® faucets manufactured after January 1, 1995 and installed in the United States of America, Canada and Mexico.

**Limitation on Duration of Implied Warranties.** TO THE EXTENT PERMITTED BY LAW, ANY IMPLIED WARRANTY, INCLUDING THE IMPLIED WARRANTIES OF MERCHANTABILITY AND OF FITNESS FOR A PARTICULAR PURPOSE, IS LIMITED TO THE STATUTORY PERIOD OR THE DURATION OF THIS WARRANTY, WHICHEVER IS SHORTER. Some states/provinces do not allow limitations on how long an implied warranty lasts, so the above limitation may not apply to you.

**Limitation of Special, Incidental or Consequential Damages.** DELTA FAUCET COMPANY SHALL NOT BE LIABLE FOR ANY SPECIAL, INCIDENTAL OR CONSEQUENTIAL DAMAGES (INCLUDING LABOR CHARGES TO REPAIR, REPLACE, INSTALL OR REMOVE THIS PRODUCT), WHETHER ARISING OUT OF BREACH OF ANY EXPRESS OR IMPLIED WARRANTY, BREACH OF CONTRACT, TORT, OR OTHERWISE. DELTA FAUCET COMPANY SHALL NOT BE LIABLE FOR ANY DAMAGE TO THE FAUCET RESULTING FROM REASONABLE WEAR AND TEAR, OUTDOOR USE, MISUSE (INCLUDING USE OF THE PRODUCT FOR AN UNINTENDED APPLICATION), FREEZING WATER, ABUSE, NEGLIGENCE OR IMPROPER OR INCORRECTLY PERFORMED INSTALLATION, MAINTENANCE OR REPAIR, INCLUDING FAILURE TO FOLLOW THE APPLICABLE INSTALLATION, CARE AND CLEANING INSTRUCTIONS. Some states/provinces do not allow the exclusion or limitation of special, incidental or consequential damages, so the above limitations and exclusions may not apply to you. Notice to residents of the State of New Jersey: The provisions of this warranty, including its limitations, are intended to apply to the fullest extent permitted by the laws of the State of New Jersey.

**Additional Rights.** This warranty gives you specific legal rights, and you may also have other rights which vary from state/province to state/province.

This is Delta Faucet Company's exclusive written warranty and the warranty is not transferable.

If you have any questions or concerns regarding our warranty, please contact us as provided above or view our Warranty FAQs at [www.deltafaucet.com](http://www.deltafaucet.com).

## 1 Cartridge Installation

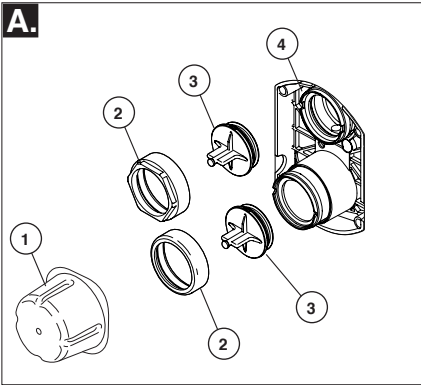

**Turn off water supplies.** Remove cover (1), bonnet nuts (2) and test caps (3) from the rough-in body (4).

Place a bucket or small container over the front of the valve body and slowly open the water supplies to flush any debris from the supply lines before installing the cartridge. Turn the water supplies back off.

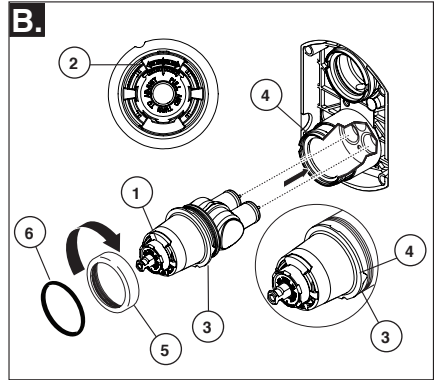

Rotate valve cartridge (1) so the words "HOT COLD" (2) appear on the top. Insert cartridge assembly into rough-in body. Make sure the key (3) on the cartridge is fully engaged with the slot in the brass body (4). Insert bonnet nut (5) on the cartridge and thread onto the body. Hand tighten securely. Slide o-ring (6) over cartridge and bonnet. A light coating of plumbers grease applied to o-rings may aid in assembly.

### Back to back Installation

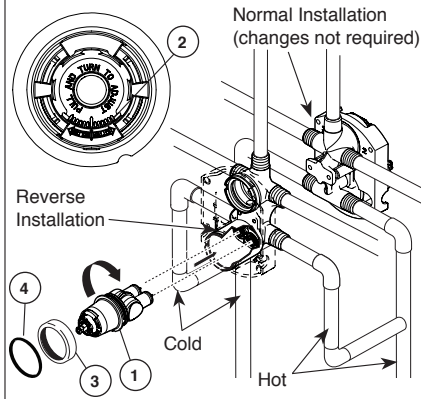

For the exceptions of back to back or reverse installations (hot on right and cold on left) only: Rotate valve cartridge (1) so "HOT COLD" (2) appears on the bottom.

Apply silicone lube to the three o-rings shown above to make the cartridge easier to install and remove from the rough-in body.

Install the cartridge making sure that the keys are fully engaged with the slot in the rough-in body (see step B).

Slide o-ring (4) and bonnet nut (3) over the cartridge and thread onto the rough-in body. Hand tighten securely.

# Installation

## 2 Diverter Cartridge Installation

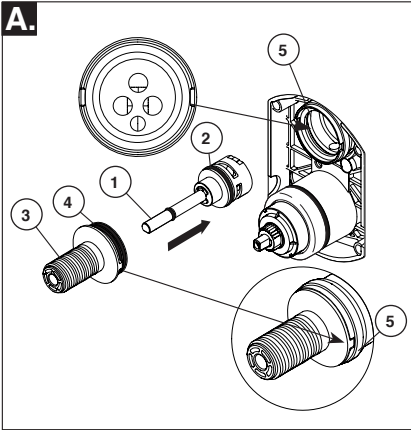

### FOR DIVERTER CARTRIDGE INSTALLATION:

Apply silicone lube to the o-ring (2) to make the diverter sleeve (3) easier to install diverter cartridge. A light coating of plumbers grease applied to o-rings (4) may aid in assembly.

Install diverter cartridge (1) assuring that the locating pin on the bottom of the cartridge aligns with mating hole in rough-in body.

Slide diverter sleeve (3) over cartridge stem aligning tabs on the diverter sleeve with slots in rough-in body (5).

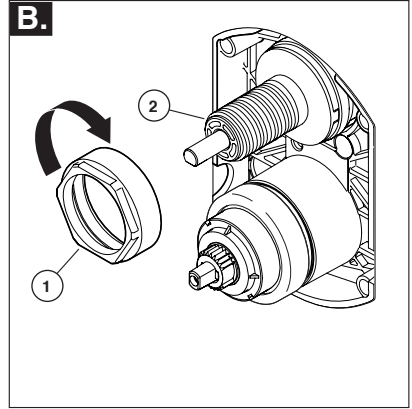

### For Bonnet Installation

Slide bonnet nut (1) over diverter sleeve (2) and thread into rough-in body. Hand tighten securely.

## Installation

### 3 Adjusting the Rotational Limit Stop

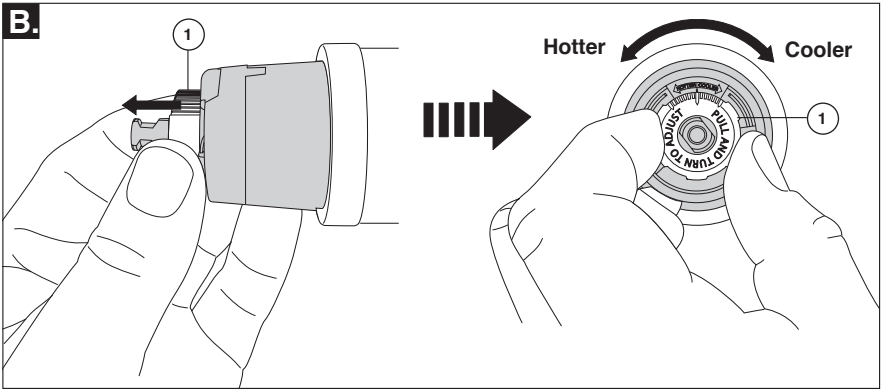

#### IMPORTANT:

The Rotational Limit Stop is used to limit the amount of hot water available such that, if set properly, a scald injury is less likely to occur if the handle accidentally is rotated all the way to “hot” when a person is showering. The first position allows the **LEAST** amount of hot water to mix with the cold water in the system. In the first position the water will be the coldest possible when the handle is turned all the way to hot. As you move the Rotational Limit Stop counterclockwise, you progressively add more and more hot water in the mix. The last position to the left will result in the greatest amount of hot water to the mix, and the greatest risk of scald injury if someone accidentally turns the valve handle all the way to the hot side while showering.

**WARNING: In some instances, setting the Rotational Limit Stop in the hottest position (full counterclockwise) could result in scald injury. It is necessary to adjust the Rotational Limit Stop so that the water coming out of the valve will not scald the user when the handle of the valve is rotated to the hot side.**

- According to the majority of industry standards, the maximum allowable temperature of the water exiting the valve is 120°F (Your local plumbing codes may require a water temperature less than 120°F).

- The Rotational Limit Stop may need to be re-adjusted seasonally if the inlet water temperature changes. For example, during the winter, the cold water temperature is colder than it is during the summer which could result in varying outlet temperatures. A water temperature for a comfortable bath or shower is typically between

90°F - 110°F.

- Run the water so that the cold water is as cold as it will get and hot water is as hot as it will get. Place the handle on the stem (see page 8, step 4C) and rotate the handle counterclockwise until the handle stops.
- Place a thermometer in a plastic tumbler and hold in the water stream. If the water temperature is above 120°F, the Rotational Limit Stop must be repositioned clockwise to decrease valve outlet water temperature to be less than 120°F or to meet the requirements of your local plumbing codes.
- To adjust the temperature of the water coming out of the valve, pull the white Rotational Limit Stop (1) outward and rotate. Clockwise rotation will decrease the outlet temperature, counterclockwise rotation will increase the outlet temperature. Temperature change per tooth (notch) could be 4° - 16°F based on inlet water conditions. Repeat as necessary. When finished, make sure that the Rotational Limit Stop is fully retracted into the seated position. **WARNING: Do not take the Rotational Limit Stop apart.**
- **MAKE SURE COLD WATER FLOWS FROM THE VALVE FIRST. MAKE SURE WATER FLOWING FROM THE VALVE AT THE HOTTEST FLOW POSSIBLE DOES NOT EXCEED 120°F OR THE MAXIMUM ALLOWED BY YOUR LOCAL PLUMBING CODE.**

# Installation

## 4 Trim Installation

A.

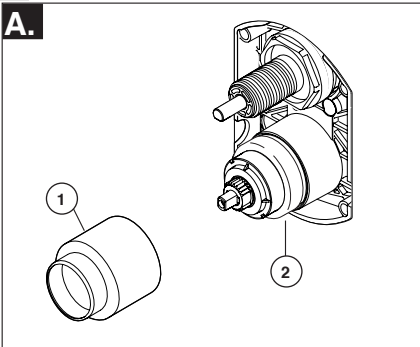

### Trim Sleeve Installation

Slide trim sleeve (1) over the bonnet (2), valve cartridge and rough-in body. Ensure sleeve is properly positioned over the front of cartridge.

B.

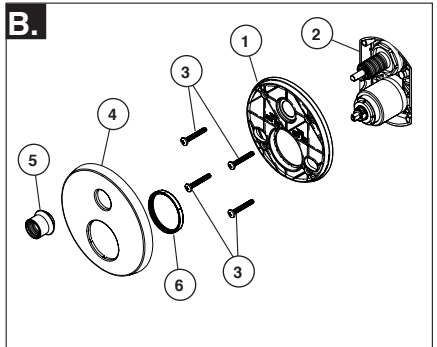

### Escutcheon Installation

For finished wall thickness up to 1 1/8". Secure the backplate (1) to the rough-in body (2) using 4 screws (3) provided.

**Note: Be sure backplate is oriented front side forward and markings are visible.**

Slide escutcheon (4) over valve and diverter cartridges, thread trim nut (5) provided onto diverter sleeve.

**Note: For thick wall installations, order installation kit RP90542 to support finished wall thickness up to 2 1/8".**

On rough or uneven surfaces it is necessary to apply caulk around the backplate (1) to supplement the seal. Do not caulk the drip notch in the bottom of the backplate (1). Do not caulk the escutcheon (4).

C.

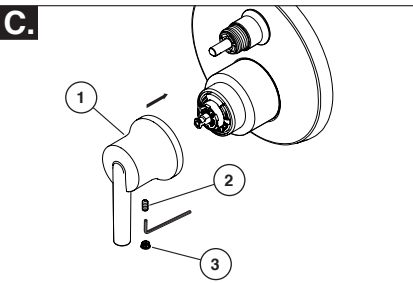

### Valve Handle Installation

Using an allen wrench, install valve handle (1) with screw (2). Applying pressure, insert button (3) until properly seated.

D.

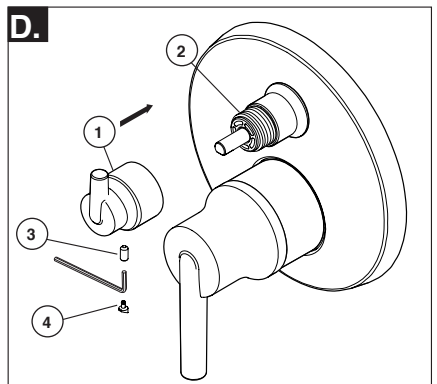

### Diverter Handle Installation

Slide diverter handle (1) onto trim sleeve (2). Using an allen wrench, insert set screw (3) into handle (1). Applying pressure, insert set screw cover (4) until properly seated.

# Diverter Handle Reference Sheet

## Water Flow For 3 Function Diverter / Flujo de agua para Desviadores de 3 posiciones / Écoulement de l'eau pour les inverseurs à 3 positions

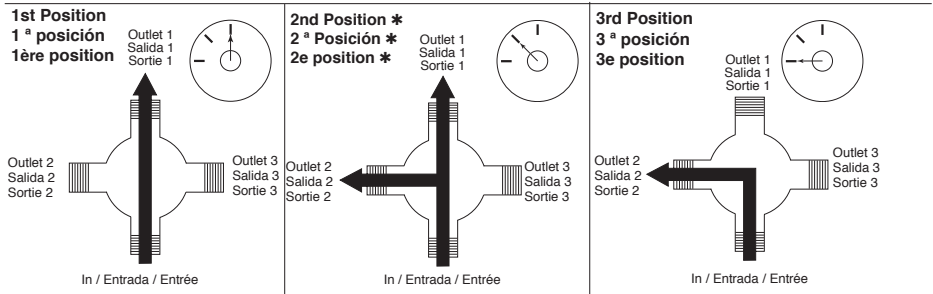

- \* Shared positions do not exist in non-shared cartridges.
- \* Los ajustes o posiciones compartidas no existen en los cartuchos no-compartidos.
- \* Comme leur nom l'indique, les cartouches sans position partagée ne comportent aucune position partagée.

## Water Flow For 6 Function Diverter / Flujo de agua para Desviadores de 6 posiciones / Écoulement de l'eau pour les inverseurs à 6 positions

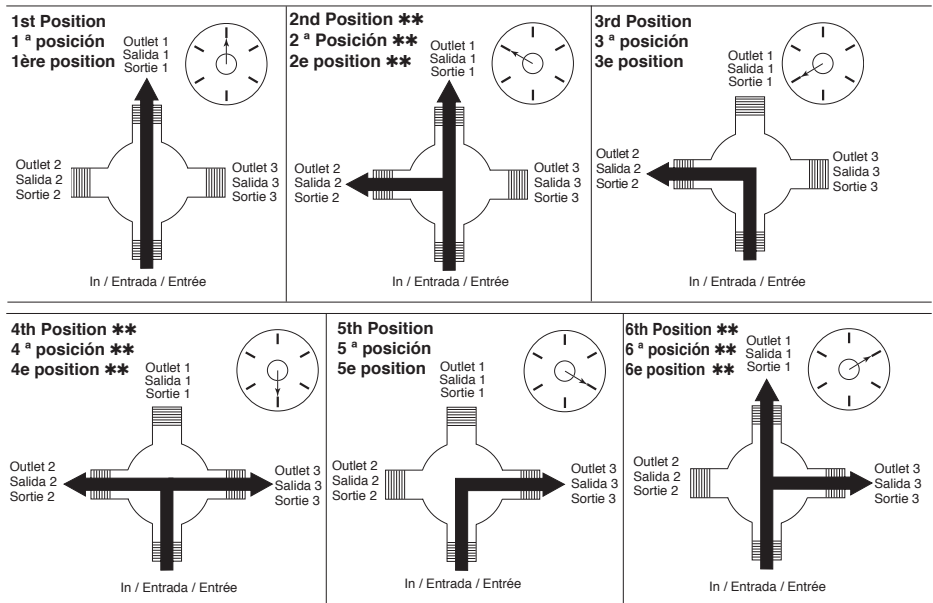

- \*\* Shared positions do not exist in non-shared cartridges.
- \*\* Los ajustes o posiciones compartidas no existen en los cartuchos no-compartidos.
- \*\* Comme leur nom l'indique, les cartouches sans position partagée ne comportent aucune position partagée.

## Clean and Care

Care should be given to the cleaning of this product. Although its finish is extremely durable, it can be damaged by harsh abrasives or polish. To clean, simply wipe gently with a damp cloth and blot dry with a soft towel.

## Maintenance

### Faucet leaks from showerhead:

SHUT OFF WATER SUPPLIES.

Replace seats and springs—Repair Kit RP4993. Check condition of lower O-rings and replace if necessary RP14414. See Helpful Hints 1, 2, & 3.

### If leak persists:

SHUT OFF WATER SUPPLIES.

Replace valve cartridge RP46074.

See Helpful Hints 1, 2, 3, 4 & 5

### Unable to maintain constant water temperature:

Replace housing assembly with RP46074 or follow instructions in Helpful Hints 1, 2, 3, 4 & 5.

### Helpful Hints:

1. Before removing valve cartridge assembly for any maintenance, be sure to note the position of the rotational limit stop on the cap. The valve cartridge assembly must always be put back in the same position. BE SAFE! After you have finished the installation, turn on valve to make sure COLD WATER FLOWS FIRST.
2. To remove valve cartridge from body, shut off

water supplies and remove handle and bonnet nut. Do not pry the valve cartridge out of the body with a screwdriver. Place handle on stem and rotate counterclockwise approximately 1/4 turn after the stop has been contacted. Lift valve cartridge out of body.

3. To remove seats and springs.

Remove valve cartridge. Separate cap assembly from the housing assembly by rotating the cap assembly counterclockwise 90° (degrees). Separate cap and housing assemblies.

4. If the water in your area has lime, rust, sand or other contaminants in it, your pressure balance valve will require periodic inspection. The frequency of the inspection will depend on the amount of contaminants in the water. To inspect valve cartridge remove it and follow the steps in note 1 above. Turn the valve to the full mix position and shake the cartridge vigorously. If there is a rattling sound, the unit is functional and can be reinstalled following instructions given in note 1 above. If there is no rattle, replace the housing assembly with the proper RP.

5. Push disc until fully seated. See page 6 for more details