



SERVICE PARTS LIST

BULLETIN NO.
54-40-2780

SPECIFY CATALOG NO. AND SERIAL NO. WHEN ORDERING PARTS		REVISED BULLETIN	DATE
M18 FUEL HP SAWZALL® Reciprocating Saw			Aug. 2022
CATALOG NO.	2722-20	STARTING SERIAL NO.	J66A
		WIRING INSTRUCTION SEE PAGE 3	

NOTE: Early production speed dial (87) had a squared top edge design. There is a new speed dial design that has a chamfered top edge. Replacement Handle Kit 14-34-2722 (93) comes with a new speed dial. If electronic assembly (94) has a speed dial with a squared top edge, replace with the new dial in the kit.

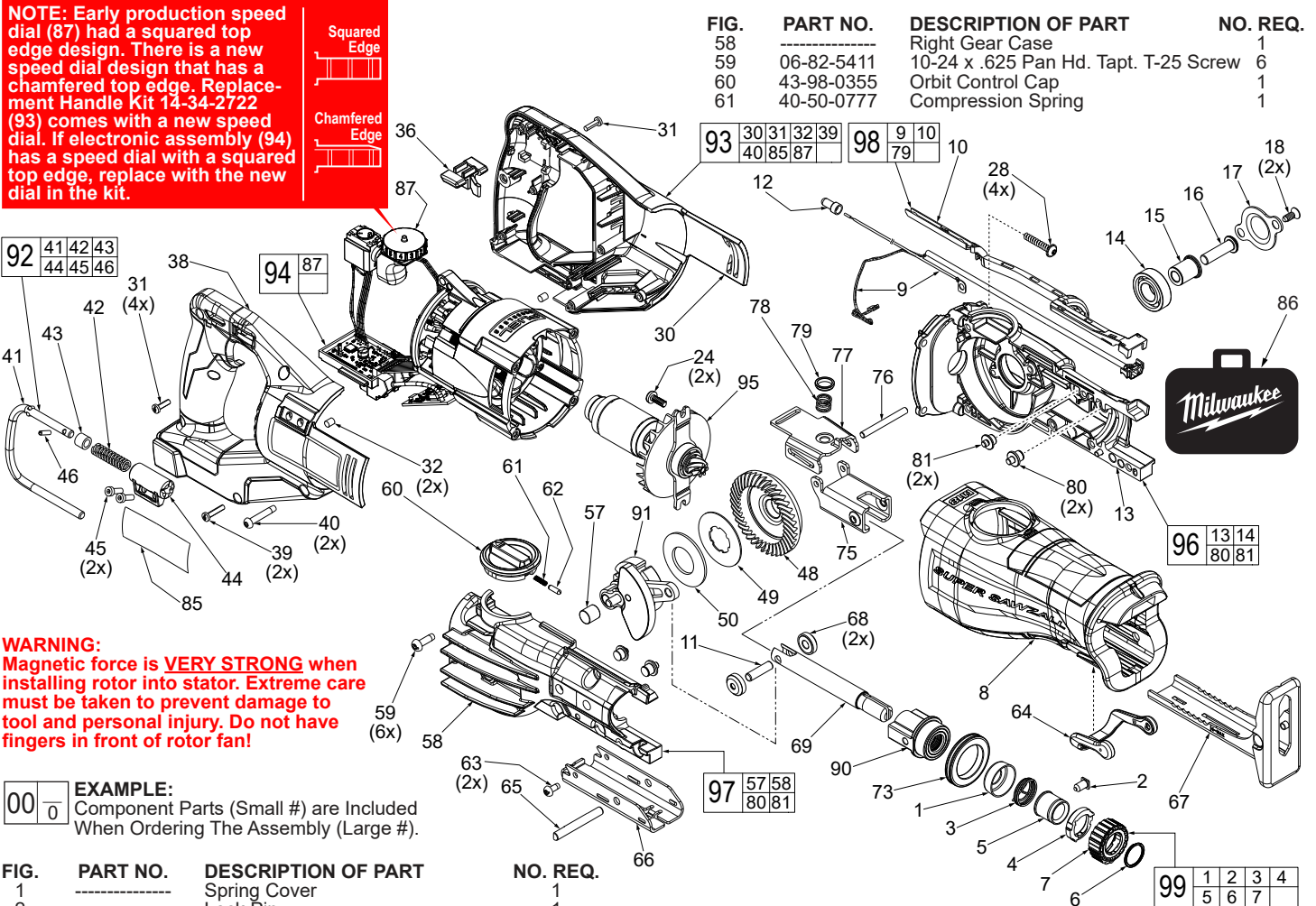

WARNING:
Magnetic force is **VERY STRONG** when installing rotor into stator. Extreme care must be taken to prevent damage to tool and personal injury. Do not have fingers in front of rotor fan!

EXAMPLE:
Component Parts (Small #) are Included When Ordering The Assembly (Large #).

FIG.	PART NO.	DESCRIPTION OF PART	NO. REQ.
1	-----	Spring Cover	1
2	-----	Lock Pin	1
3	-----	Torsion Spring	1
4	-----	Rear Cam	1
5	-----	Sleeve	1
6	34-60-3700	Retaining Ring	1
7	-----	Front Cam	1
8	45-12-0365	Boot	1
9	-----	LED Assembly	1
10	-----	LED Tray	1
11	06-65-0865	Roller Pin	1
12	22-56-0005	Closed End Terminal	1
13	-----	Left Gear Case	1
14	02-04-1510	Ball Bearing	1
15	42-40-0076	Spacer	1
16	06-08-0019	Drive Hub Bolt (LH)	1
17	44-66-0280	Bearing Retaining Plate	1
18	06-82-8890	1/2-DG50 Thread Form T-25 Screw	2
24	06-82-5324	10-24 x 1/2 Pan Hd. Taptite T-25 Screw	2
28	06-82-2700	M5 x 35mm Pan Hd. PT T-20 Screw	4
30	-----	Left Housing Halve - Support	1
31	06-82-7240	6-19 x 1/2" Pan Hd. ST T-15 Screw	4
32	45-30-1000	Rubber Slug	2
36	42-42-1200	Lock Off Shuttle	1
38	-----	Right Housing Halve - Cover	1
39	06-82-7261	6-19 x .687 Pan Hd. Slit. Plast. T-15 Scr.	2
40	06-95-1001	8-16 x 27mm Pan Hd. Tapt. T-20 Screw	2
41	-----	Rafter Hook	1
42	-----	Rafter Hook Spring	1
43	-----	Rafter Hook Bushing	1
44	-----	Rafter Hook Mounting Bracket	1
45	05-78-0910	M4 x 12mm Fillister Hd. Screw	2
46	-----	Spring Pin	1
48	32-05-1070	Bevel Gear	1
49	43-06-0025	Metal Plate	1
50	40-50-0787	Disc Spring	1
57	02-50-1640	Needle Bearing	1

FIG.	PART NO.	DESCRIPTION OF PART	NO. REQ.
58	-----	Right Gear Case	1
59	06-82-5411	10-24 x .625 Pan Hd. Tapt. T-25 Screw	6
60	43-98-0355	Orbit Control Cap	1
61	40-50-0777	Compression Spring	1
93	30 31 32 39 40 85 87	Handle Kit	1
98	9 10 79	LED and Tray Assembly	1
10	-----	LED Tray	1
12	-----	Closed End Terminal	1
18	-----	Ball Bearing	1
17 (2x)	-----	Spacer	2
16	-----	Drive Hub Bolt (LH)	1
15	-----	Bearing Retaining Plate	1
14	-----	1/2-DG50 Thread Form T-25 Screw	2
13	-----	Left Gear Case	1
12	-----	Ball Bearing	1
11	-----	Roller Pin	1
10	-----	LED Tray	1
9	-----	LED Assembly	1
8	-----	Boot	1
7	-----	Front Cam	1
6	-----	Retaining Ring	1
5	-----	Sleeve	1
4	-----	Rear Cam	1
3	-----	Torsion Spring	1
2	-----	Lock Pin	1
1	-----	Spring Cover	1
99	1 2 3 4 5 6 7	Blade Clamp Assembly	1
99	-----	FUEL Contractor Bag - Large	1
86	-----	Service Nameplate	1
85	-----	Plastic Sleeve	1
79	-----	Orbit Spring	1
78	-----	Orbit Slot	1
77	-----	Orbit Angle Bracket	1
76	-----	Orbit Slider Pin	1
75	-----	H' Orbit Seal	1
73	-----	Spindle	1
69	-----	Front Bushing Assembly	1
68	-----	Speed Dial	1
67	-----	Shoe Retainer	1
66	-----	Shoe Assembly	1
65	-----	Shoe Pin	1
64	-----	Shoe Release Lever	1
63	-----	Orbital Detent Pin	1
62	-----	8-32 x 3/8" Pan Hd. Slit. Tapt. T-20 Scr.	2
91	-----	Crank Shaft Assembly	1
90	-----	14-86-0105	1
81	-----	Orbit Slot Pin	2
80	-----	Pivot Pin	2

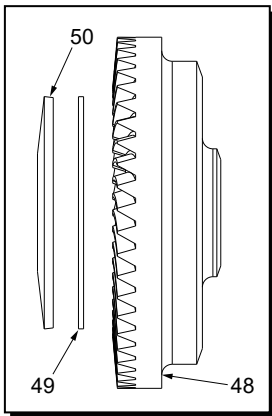
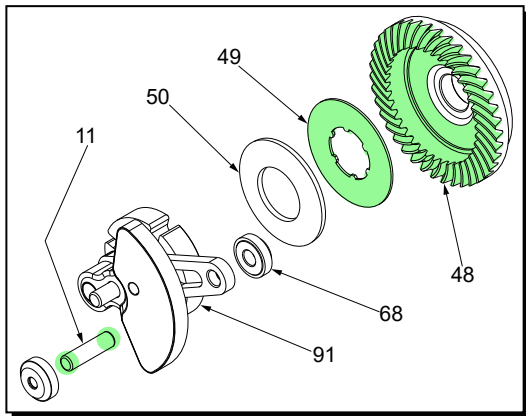

Concave side of disc spring (50) must face toward metal plate (49) and bevel gear (48).

Pinion Gear of Rotor Assembly #95

NOTE: Orbit Slot #75 has been removed from this view for clarity (to reveal Connecting Rod Pin #18 and Rollers #17)

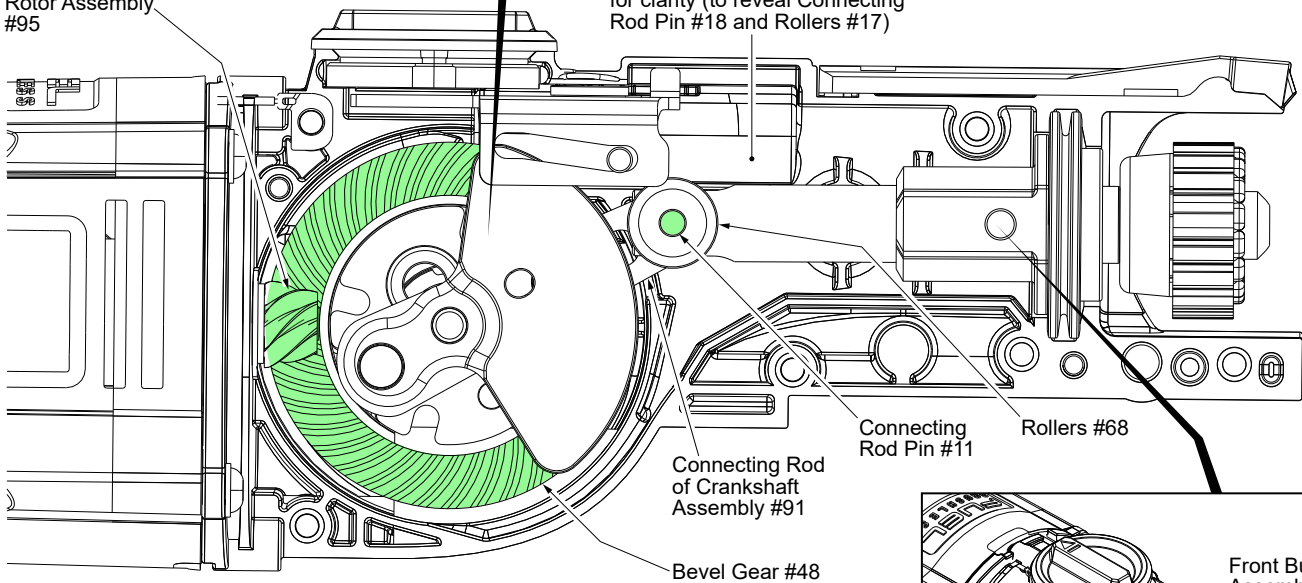

LUBRICATION: Type 'T' Grease
No. 49-08-4290 (16 oz. can)

- Place 30g ±3g (approx. 1 ounce) on top of gear (48) and pinion gear of rotor assembly (95), being sure to cover the middle of the gear and all teeth.
- Place 15g ±3g (approx. .5 ounce) to the area where the gear (48) and the connecting rod of crank shaft assembly (91) interface.
- Coat both sides of the metal clutch plate (49).
- Lightly coat both pivot pins (80) where connections go into holes of front bushing assembly (90).
- Lightly coat both ends of pin (11) prior to installing rollers (68).

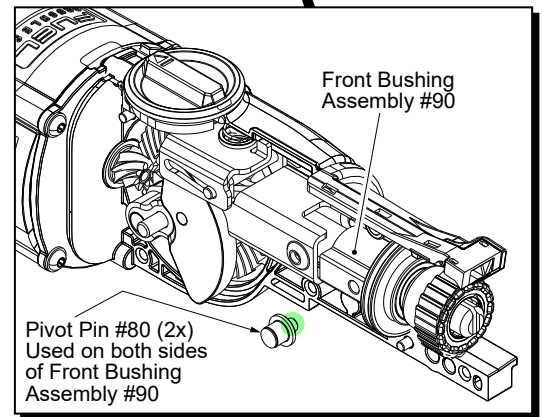

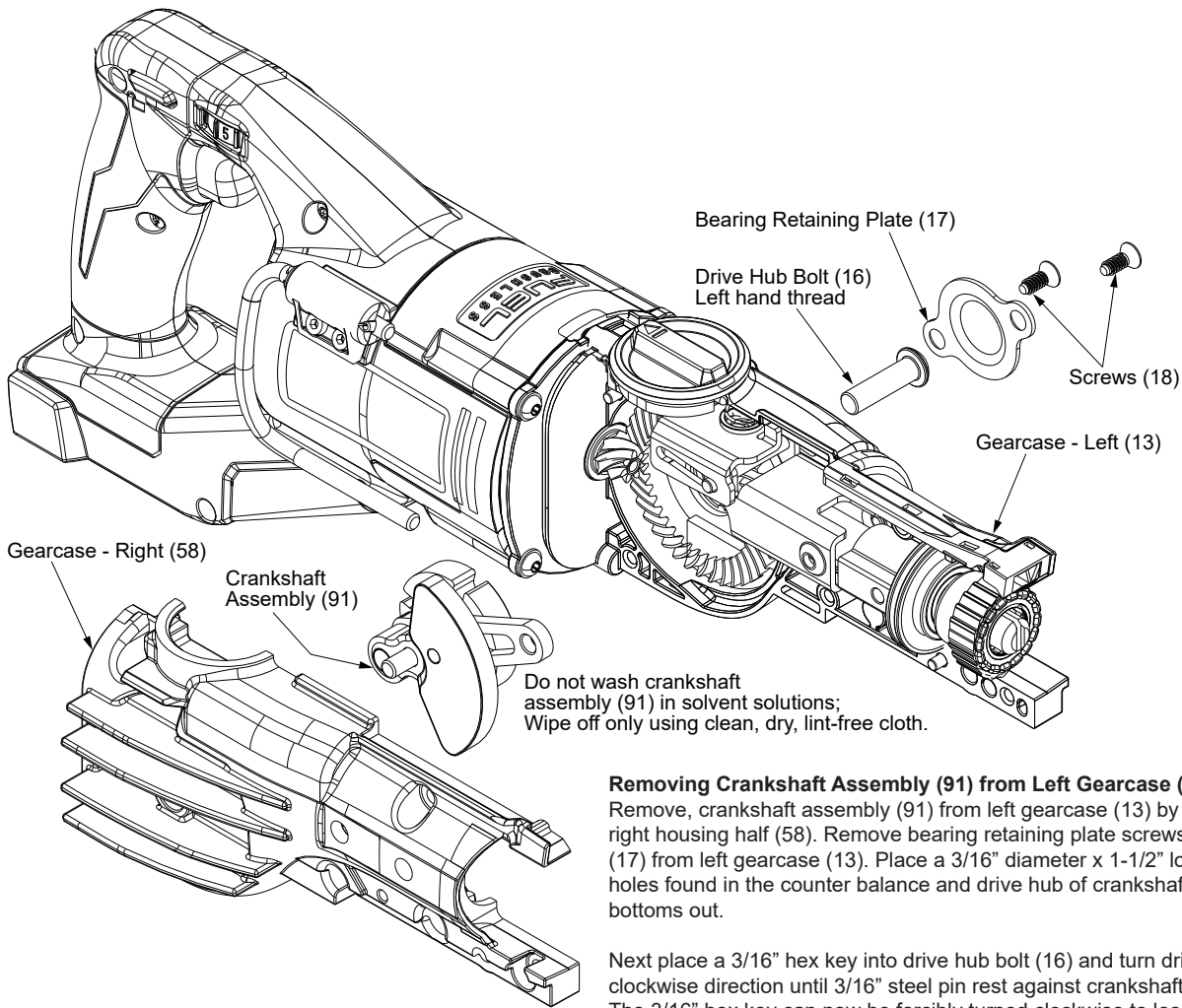

Removing Crankshaft Assembly (91) from Left Gearcase (13)

Remove, crankshaft assembly (91) from left gearcase (13) by separating / removing right housing half (58). Remove bearing retaining plate screws (18) and bearing plate (17) from left gearcase (13). Place a 3/16" diameter x 1-1/2" long steel rod through holes found in the counter balance and drive hub of crankshaft assembly (91) until it bottoms out.

Next place a 3/16" hex key into drive hub bolt (16) and turn drive hub bolt slowly in a clockwise direction until 3/16" steel pin rest against crankshaft assembly connecting rod. The 3/16" hex key can now be forcibly turned clockwise to loosen and remove drive hub bolt (16).

Reinstalling Crankshaft Assembly (91) into Left Gearcase (13)

To reinstall drive hub bolt (16) to crankshaft assembly (91) apply Blue Loctite® (44-20-0090) to threads of drive hub bolt (16) and insert through spacer (15) aligning threads of drive hub bolt (16) with internal threads of crankshaft assembly hub. Use a 3/16" hex key to turn the drive hub bolt (16) slowly in a counter clockwise direction until 3/16" steel pin rest against crankshaft assembly connecting rod (See 'Removing Crankshaft Assembly' instructions above). Using an inch pound torque wrench and a 3/16" hex key, torque drive hub bolt (16) to 210-240 in. lbs. or bolt can be tightened using a ft. lbs. torque wrench to 17-20 ft. lbs.

SCREW TORQUE SPECIFICATIONS				
FIG.	PART NO.	WHERE USED	SEAT TORQUE	
			(KG/CM)	(IN/LBS)
16	06-08-0019	Crankshaft Assy.	240-275	208-238
18	06-82-8890	Bearing Plate	55-63	47-54
24	06-82-5324	Retaining Plate	46-58	39-50
28	06-82-2700	Gearcase	35-40	30-34
31	06-82-7240	Both Housing Halves	12-17	10-14
39	06-82-7261	Right Housing Halve	12-17	10-14
40	06-95-1001	Right Housing Halve	20-25	17-21
45	05-78-0910	Rafter Hook Bracket	20-25	17-21
59	06-82-5411	Gearcase	46-58	39-50
63	06-82-7253	Shoe Retainer	25-35	21-30

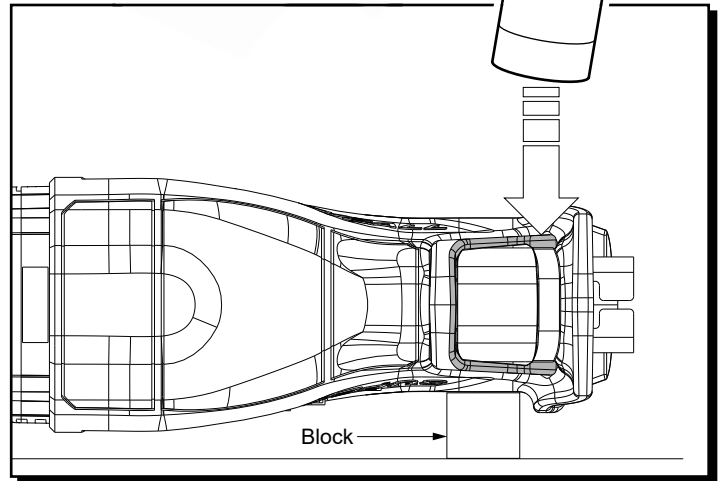
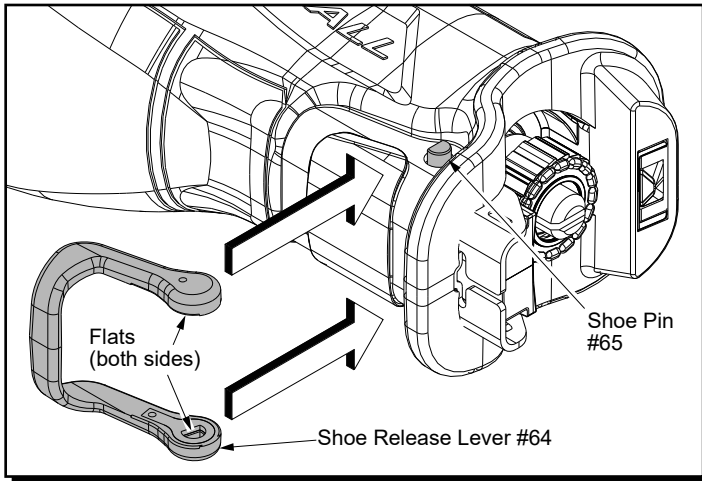
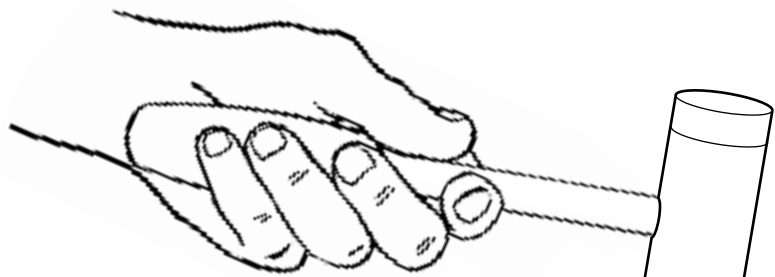

To properly install the Shoe Release Lever #64 onto the Shoe Pin #65 do the following:

Insert the shoe pin through the hole in the gearcase insulator. Center the shoe pin with equal amounts of the pin protruding from each side of the tool.

Rotate the shoe pin so the flats of the pin will align with the flats in the shoe release lever cavities.

The shoe release lever is stiff but flexible. Place the shoe release lever over the gearcase insulator. Lift one end of the shoe release lever onto the shoe pin (with flats aligned) and press into place.

Pull the other end of the shoe release lever over the other side of the pin and press in place.

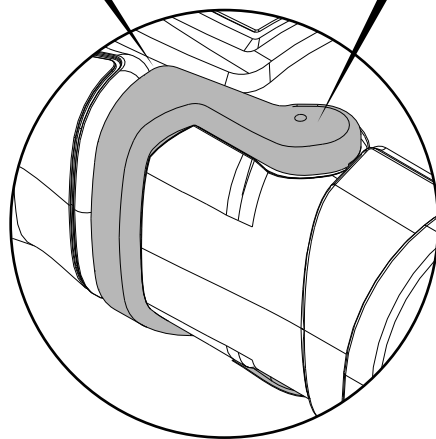

Place the tool on its side on a hard flat surface. Place a small wood block approximately 1-1/8" thick under the tool, between the hard surface and the shoe release lever, directly beneath the pin.

With a rubber mallet, strike the shoe release lever several times to completely seat the lever onto the pin and to assure that the pin is properly centered within the gearcase.

REMOVING THE STEEL QUIK-LOK® BLADE CLAMP -

- Remove external retaining ring (6) and pull front cam (7) off.
- Pull lock pin (2) out and remove remainder of parts and discard.

REASSEMBLY OF THE STEEL QUIK-LOK® BLADE CLAMP

- Coat new lock pin with powdered graphite.
- Hold tool in a vertical position.
- Place spring cover (1) onto spindle.
- Slide torsion spring (3) onto spindle with spring leg on hole side of spindle.
- Slide sleeve (5) onto spindle aligning hole on sleeve with hole in spindle.
- Slide rear cam (4) over sleeve until it bottoms on sleeve shoulder, ensure spring leg inserts into groove of cam.
- Rotate rear cam in the direction of the arrows located on spring cover until there is clearance for lock pin (2) to be inserted into sleeve/spindle holes. Insert lock pin.
- Align front cam (7) inner ribs with rear cam outer slots and slide front cam onto sleeve until it bottoms. Retaining ring groove should be completely visible.
- Attach retaining ring (6) by separating coils and inserting end of ring into groove, then wind remainder of ring into groove. Ensure ring is seated in groove.
- Blade clamp should rotate freely. During normal usage, debris may not allow blade clamp to rotate freely. The use of spray lubricant can help free blade clamp. In extreme conditions, follow these instructions to remove, clean and reassemble blade clamp.

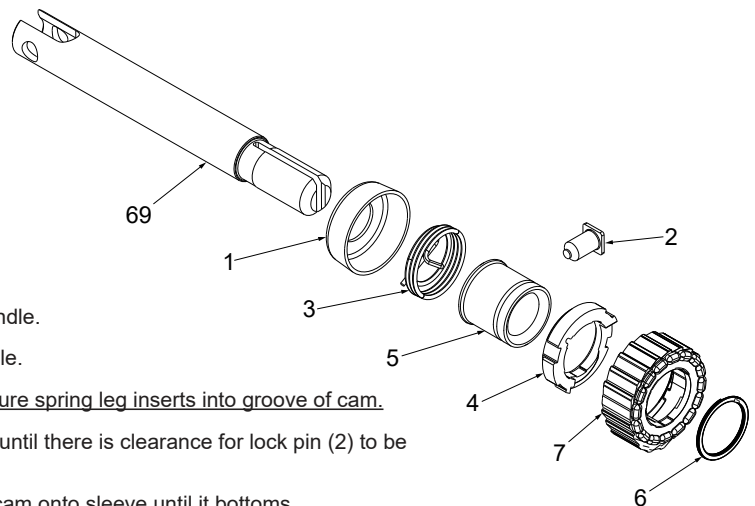

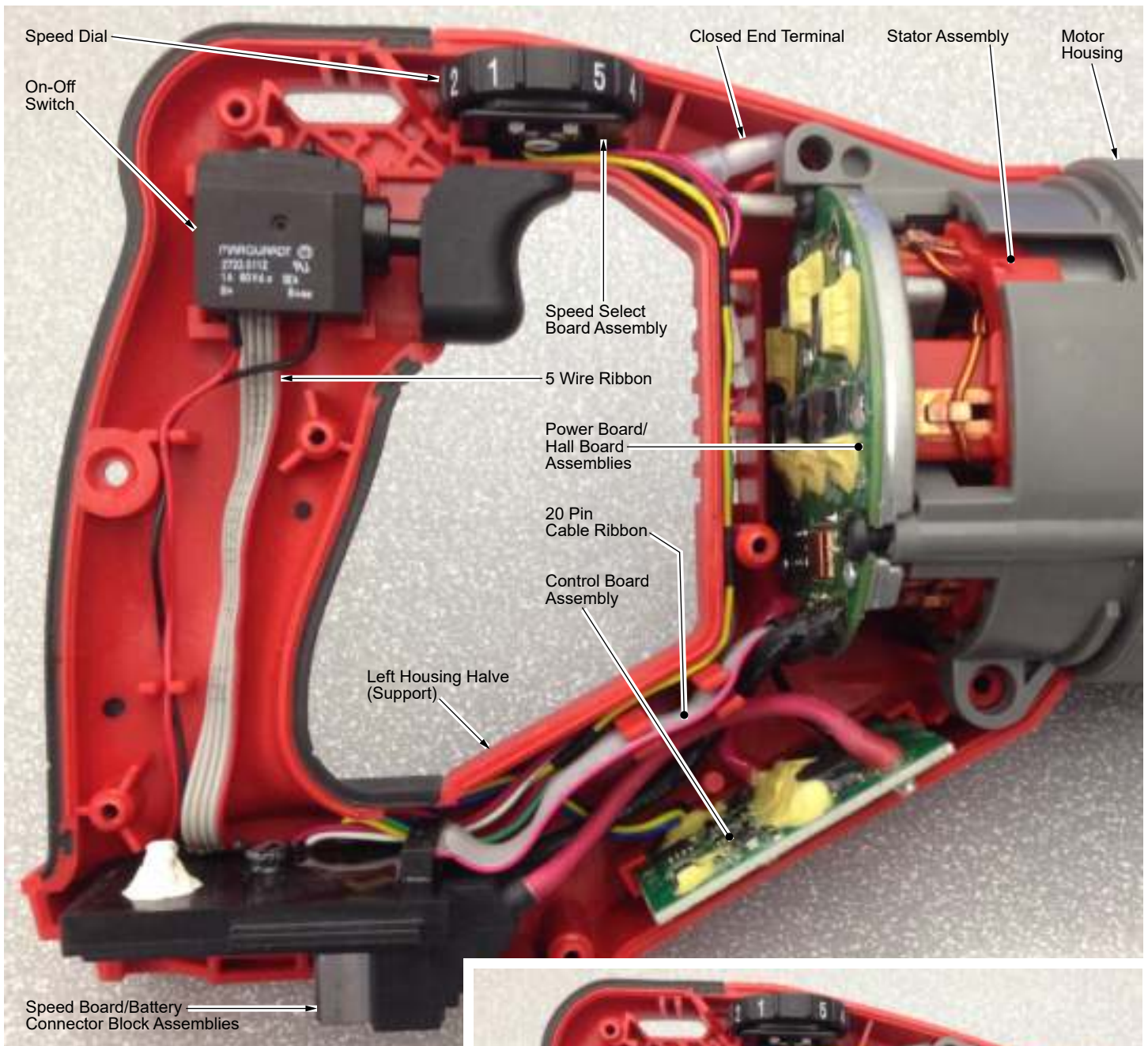

SEE PAGE 6 FOR ADDITIONAL WIRING VIEWS

Prior to installing Right Handle/Housing Halve (38) onto left housing/handle halve (30), be sure that all wires are tucked down in wire traps. Be sure that wire ribbons are properly placed down in traps and channels. Make sure that all elements of electronics assembly (94) are firmly and squarely in the corresponding cavities of left handle/housing halve.

Secure right handle/housing halve to left handle/housing halve with screws (31, 39 and 40), watching out for pinched wires.

Prior to installing battery, check for the proper functionality of the on-off switch, Speed Dial (87) and Lock-Off Shuttle (36).

Install battery and assure the tool operates properly.

