

► **Description**

Exposed, Hardwire, Sensor Activated Sloan ECOS® Hardwire Urinal Flushometer with Smart Sense Technology™.

► **Flush Cycle**

- Model 186-0.13 High Efficiency (0.13 gpf/0.5 Lpf)
- Model 186-0.25 High Efficiency (0.25 gpf/0.9 Lpf)
- Model 186-0.5 High Efficiency (0.5 gpf/1.9 Lpf)

► **Specifications**

Quiet, Exposed, Diaphragm Type, Chrome Plated Urinal Flushometer for either left or right hand supply with the following features:

For flushing volumes 0.13 gpf and 0.25 gpf:

- Pressure compensating cartridge assembly
- Synthetic rubber seals for chloramine resistance

For flushing volume 0.5 gpf:

- PERMEX™ Synthetic Rubber Diaphragm with twin linear filtered bypass and vortex cleansing action
- Flex Tube Diaphragm designed for improved life and reduced maintenance
- Flush Accuracy Controlled by CID™ Technology

For **all** flushing volumes:

- Line Powered with 6 VAC Step Down Transformer
- Latching Solenoid Operator
- Engineered Metal Cover with replaceable Lens Window
- User friendly three (3) second Flush Delay
- Optional Courtesy Flush™ Override Button
- 3/4" I.P.S. Screwdriver Bak-Chek® Angle Stop
- Infrared Sensor Range Adjustment Screw
- Initial Set-up Range Indicator Light (first 10 minutes)
- Infrared Sensor with Multiple-focused, Lobular Sensing Fields for high and low target detection
- Free Spinning, Vandal Resistant Stop Cap
- ADA Compliant Sloan ECOS® Electronic Infrared Sensor or automatic "No Hands" operation
- Adjustable Tailpiece
- High Back Pressure Vacuum Breaker Flush Connection with One-piece Bottom Hex Coupling Nut
- Spud Coupling and Flange for 3/4" Top Spud
- Reduces water usage up to 80% over standard sensor urinals
- Sweat Solder Adapter with Cover Tube and Cast Wall Flange with Set Screw
- High Copper, Low Zinc Brass Castings for Dezincification Resistance
- Fixed Metering Bypass and No External Volume Adjustment to Ensure Water Conservation
- Stop Seat and Vacuum Breaker molded from PERMEX™ Rubber Compound for Chloramine resistance

Valve Body, Tailpiece and Control Stop shall be in conformance with ASTM Alloy Classification for Semi-Red Brass. Valve shall be in compliance with the applicable sections of ASSE 1037. Installation conforms to ADA requirements.

► **Special Finishes**

- PB** Polished Brass (PVD Finish)
- BN** Brushed Nickel (PVD Finish)
- SF** Satin Chrome

► **Accessories**

- EL-386** Transformer Plug (120 VAC/6 VAC)
 - EL-451** Transformer Box (120 VAC/6 VAC 25VA)
- See Accessories Section and Sloan ECOS® Electronic Accessories Section of the Sloan catalog for details on these and other Sloan ECOS® Electronic Flushometer variations.

► **Fixtures**

Consult Sloan for matching Sloan brand fixture options.



Shown without optional override button

► **ADA Compliant**

► **Manual Operation**

Sloan ECOS® Hardwire Urinal Flushometers are available without an override button to eliminate unnecessary casual activation. Sloan ECOS® Urinal Flushometers are offered with an *optional* Override Button to allow a "courtesy flush" for individual user comfort.

► **Automatic Operation**

Sloan ECOS® Hardwire Urinal Flushometers can also be activated via multi-lobular infrared sensor. By detecting user presence and duration, the Sloan ECOS® Smart Sense Technology™ will determine the proper flush volume for unequalled water efficiency.

► **Smart Sense Technology™**

The Sloan ECOS® Flushometers are equipped with Smart Sense Technology™ which applies extended range and logic techniques to significantly reduce water usage in high use urinal applications; such as when a continuous line of people, also known as a queue, forms. In fact, during a continuous queue, regardless of the number of users, the maximum amount of water used is only 2.0 gallons (186-0.5). Please contact Sloan for specific details.

► **Functional & Hygienic**

Touchless, sensor operation eliminates the need for user contact to help control the spread of infectious diseases.

► **Warranty**

Three (3) year (limited)

► **Patented**

D598,974



This space for Architect/Engineer approval	
Job Name _____	Date _____
Model Specified _____	Quantity _____
Variations Specified _____	
Customer/Wholesaler _____	
Contractor _____	
Architect _____	

Description
Exposed, Hardwire, Sensor Activated Sloan ECOS® Hardwire Urinal Flushometer with Smart Sense Technology™.

- Flush Cycle**
- Model 186-0.13 High Efficiency (0.13 gpf/0.5 Lpf)
 - Model 186-0.25 High Efficiency (0.25 gpf/0.9 Lpf)
 - Model 186-0.5 High Efficiency (0.5 gpf/1.9 Lpf)

ELECTRICAL SPECIFICATIONS

- | | |
|---|--|
| <p>Control Circuit
Solid State
120 VAC Input
4.5 VAC Output
8 Second Arming Delay
3 Second Flush Delay</p> <p>Sloan ECOS® Sensor Type
Active Infrared</p> <p>Sloan ECOS® Sensor Range
Nominal 22" - 42" (559 mm - 1067 mm),
Adjustable ± 8" (203 mm)</p> | <p>Indicator Lights
Range Adjustment</p> <p>Operating Pressure
15 - 100 psi (104 - 689 kPa)</p> <p>Sentinel Flush
Once Every 72 Hours After the Last Flush</p> <p>Transformers
Sloan Part No. EL-386
120 VAC, 60 Hz Primary
6 VAC, 60 Hz Secondary
Class II, 1/2 Amp - Plug-in Style</p> |
|---|--|

Sloan Part No. EL-451
120 VAC, 60 Hz Primary
6 VAC, 60 Hz Secondary
Class II, 25 VA - Box Style

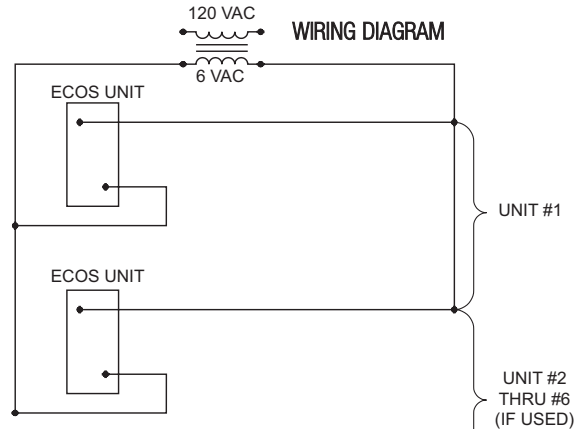

One 25 VA Transformer serves up to six Sloan ECOS® units.

VALVE ROUGH-IN

Model 186

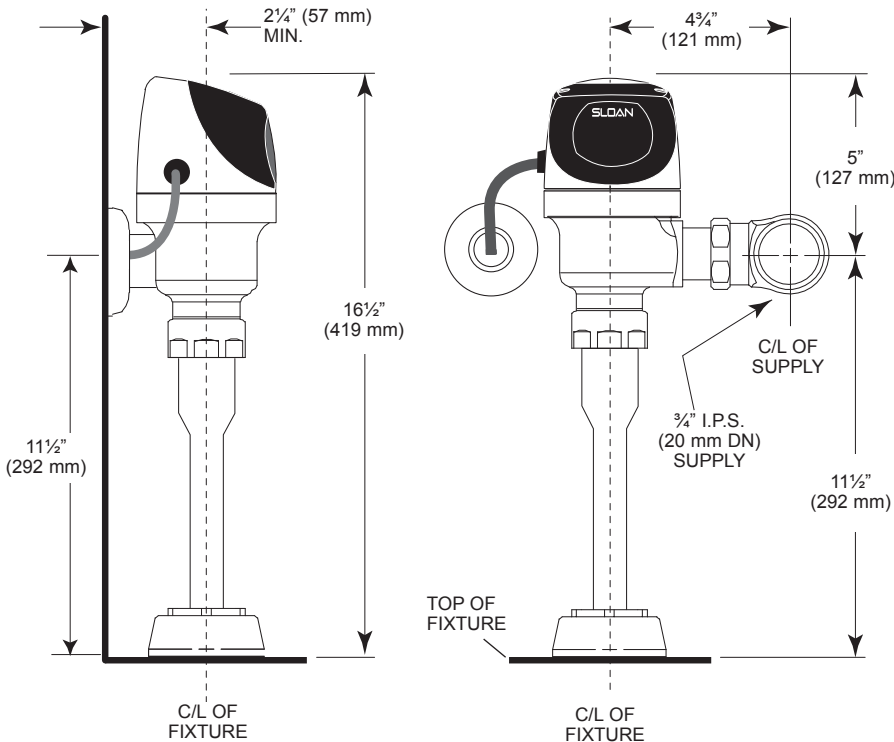

OPERATION

1. A continuous, invisible light beam is emitted from the Sloan ECOS® Sensor.

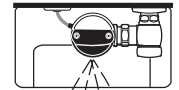

2. As the user enters the beam's effective range, 15" - 30" (381 mm to 762 mm), the beam is reflected into the Scanner Window to activate the Output Circuit. Once activated, the Output Circuit continues in a "hold" mode as long as the user remains within the effective range of the sensor. If the user stays longer than 65 seconds, a full flush will automatically initiate when the user leaves.

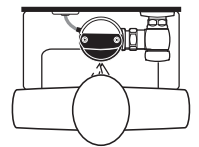

3. When the user steps away from the Sloan ECOS® sensor the sensor initiates an electrical signal that operates the solenoid. This initiates the flushing cycle to flush the fixture. The circuit then automatically resets and is ready for the next user.

