

NEVER LEAVE THE HEATER UNATTENDED WHILE BURNING!

OPERATING INSTRUCTIONS AND OWNER'S MANUAL



FORCED-AIR PROPANE CONSTRUCTION HEATER

Model #

MH400FAVT

READ INSTRUCTIONS CAREFULLY: Read and follow all instructions. Place instructions in a safe place for future reference. Do not allow anyone who has not read these instructions to assemble, light, adjust or operate the heater.



WARNING: If the information in this manual is not followed exactly, a fire or explosion may result causing property damage, personal injury or loss of life.

- Do not store or use gasoline or other flammable vapors and liquids in the vicinity of this or any other appliance.
- An LP cylinder not connected for use shall not be stored in the vicinity of this or any other appliance.
- WHAT TO DO IF YOU SMELL GAS
 - Do not try to light appliance.
 - Extinguish any open flame.
 - Shut off gas to appliance.
- Service must be performed by a qualified service agency.

This is an unvented gas-fired portable heater. It uses air (oxygen) from the area in which it is used. Adequate combustion and ventilation air must be provided. Refer to page 3.

WARNING:

⚠ YOUR SAFETY IS IMPORTANT TO YOU AND TO OTHERS, SO PLEASE READ THESE INSTRUCTIONS BEFORE YOU OPERATE THIS HEATER.

GENERAL HAZARD WARNING:

- ⚠ FAILURE TO COMPLY WITH THE PRECAUTIONS AND INSTRUCTIONS PROVIDED WITH THIS HEATER, CAN RESULT IN DEATH, SERIOUS BODILY INJURY AND PROPERTY LOSS OR DAMAGE FROM HAZARDS OF FIRE, EXPLOSION, BURN, ASPHYXIATION, CARBON MONOXIDE POISONING, AND/OR ELECTRICAL SHOCK.
- ⚠ ONLY PERSONS WHO CAN UNDERSTAND AND FOLLOW THE INSTRUCTIONS SHOULD USE OR SERVICE THIS HEATER.
- ⚠ IF YOU NEED ASSISTANCE OR HEATER INFORMATION SUCH AS AN INSTRUCTIONS MANUAL, LABELS, ETC. CONTACT THE MANUFACTURER.

WARNING:

⚠ **CARBON MONOXIDE CAN KILL**
 USING A PORTABLE HEATER IN AN ENCLOSED AREA CAN PRODUCE DEADLY CARBON MONOXIDE. NOT FOR HOME OR RECREATIONAL VEHICLE USE

WARNING:

⚠ FIRE, BURN, INHALATION, AND EXPLOSION HAZARD. KEEP SOLID COMBUSTIBLES, SUCH AS BUILDING MATERIALS, PAPER OR CARDBOARD, A SAFE DISTANCE AWAY FROM THE HEATER AS RECOMMENDED BY THE INSTRUCTIONS NEVER USE THE HEATER IN SPACES WHICH DO OR MAY CONTAIN VOLATILE OR AIRBORNE COMBUSTIBLES, OR PRODUCTS SUCH AS GASOLINE, SOLVENTS, PAINT THINNER, DUST PARTICLES OR UNKNOWN CHEMICALS.

⚠ **WARNING:** THIS PRODUCT CAN EXPOSE YOU TO CHEMICALS INCLUDING LEAD AND LEAD COMPOUNDS, WHICH ARE KNOWN TO THE STATE OF CALIFORNIA TO CAUSE CANCER AND BIRTH DEFECTS OR OTHER REPRODUCTIVE HARM. FOR MORE INFORMATION VISIT WWW.P65WARNINGS.CA.GOV

⚠ **WARNING:** Fuels used in liquefied propane gas appliances, and the products of combustion of such fuel, can expose you to chemicals including benzene, which is known to the state of California to cause cancer and cause birth defects or other reproductive harm, for more information go to www.P65Warnings.ca.gov

CONTENTS

Specifications..... 2

Operating Precautions 3

Safety Precautions 3

Odor Fade Warning 4

Operating Instructions 5

Storage & Service 5

Wiring Diagram 6

Parts List..... 7

Exploded View Drawing..... 7

SPECIFICATIONS

MODEL NO. 400FAVT

GAS TYPE..... Propane

BTU RATING..... 210,000-400,000 BTU/hr
 (61.5 – 117 kW)

GAS SUPPLY PRESSURE TO REGULATOR
 Maximum: **Bottle Pressure**, Minimum: **20 psig (0.14 MPa)**

REGULATOR OUT20 psig (0.14 MPa)

ELECTRICAL INPUT 115V, 60 Hz, 1Ø, 5.5a

IGNITION..... Direct Spark, interrupted type

PRIMARY FLAME CONTROL SolidState, 10-15 sec. timing

HIGH TEMPERATURE CONTROL 240°F (116°C)
 Minimum Ambient Temp Rating: 0°F (-17.8°C)

FUEL CONSUMPTION 9.3- 18.5 lbs/hr
 (4.2 – 8.4 kg/hr)

FUEL ORIFICE PORT NO.: 1

FUEL ORIFICE PORT SIZE:.....2.35 MM

HEATED AIR OUTPUT: 1400 CFM (39.6 CU-M/M)

NEVER LEAVE THE HEATER UNATTENDED WHILE BURNING!

OPERATING PRECAUTIONS

This is a propane, direct-fired, forced air heater. Its intended use is primarily temporary heating of buildings under construction, alteration or repair.

Propane is heavier than air. If propane leaks from a connection or fitting, it sinks to the floor, collecting there with the surrounding air, forming a potentially explosive mixture. Obviously, propane leaks should be avoided, so set up the propane supply with utmost care. Read enclosed Odor Fade and Propane Sheet for additional information about detecting propane leaks. Leak check new connections or reconnections with a soap and water solution and follow all connection instructions herein. Also, ask your propane dealer for advice on the propane application and supply installation and ask him to check it if there are any questions.

This heater was designed and certified for use as a construction heater in accordance with ANSI Standard Z83.7/CGA 2.14. Check with your local fire safety authority if you have any questions about your applications. Other standards govern the use of fuel gases and heat producing products in specific applications. Your local authority can advise you about these.

Direct-Fired means that all of the combustion products enter the heated space. Even though this heater operates very close to 100 percent combustion efficiency, it still produces small amounts of carbon monoxide. Carbon monoxide (called CO) is toxic. We can tolerate small amounts but not a lot. CO can build up in a heated space and failure to provide adequate ventilation could result in death.

The symptoms of inadequate ventilation are:

- headache
- dizziness
- burning eyes and nose
- nausea
- dry mouth or sore throat

So, be sure to follow advice about ventilation in these operating instructions.

Forced Air means that a blower or fan pushes the air through the heater. Proper combustion depends upon this air flow; therefore, the heater must not be revised, modified or operated with parts removed or missing. Likewise, safety systems must not be circumvented or modified in order to operate the heater.

When the heater is to be operated in the presence of other people the user is responsible for properly acquainting those present with the safety precautions and instructions, and of the hazards involved.

Figure 1

VENTILATION: Minimum openings required

Heater	Opening near floor	Opening near ceiling
Forced air (400 FAVT)	3.5 ft ²	3.5 ft ²

SAFETY PRECAUTIONS

1. Check the heater thoroughly for damage. DO NOT operate a damaged heater.
2. DO NOT modify the heater or operate a heater which has been modified from its original condition.
3. Use only propane gas.
4. Use only VAPOR WITHDRAWAL propane supply. If there is any question about vapor withdrawal, ask your propane dealer.
5. Mount the propane cylinders vertically (shutoff valve up). Secure them from falling or being knocked over and protect them from damage.
6. Locate propane containers at least (USA) 7 ft. (2.13m), (Canada) 10 ft. (3m) from the heater and **do not** direct exhaust toward containers.
7. **IMPORTANT** Use only the hose and regulator assembly provided with the heater. Match the color stripe on the hangtag attached to the hose assembly with the color on the label located near the propane inlet fitting on the heater. Inspect hose assembly before each use of the heater. If there is excessive abrasion or wear, or hose is cut, replace with hose assembly listed on parts list before using heater.
8. For indoor use only. Area must be well ventilated. **Figure 1** (also see "Operating Precautions").
9. If at any time gas odor is detected, IMMEDIATELY DISCONTINUE operation until the source of gas has been located and corrected. Read enclosed Odor fade and Propane Sheet for additional information about detecting propane leaks.
10. Install the heater such that it is not directly exposed to water spray, rain and/or dripping water.
11. Maintain minimum clearance from normal combustible material (like paper). **Figure 2**
12. Due to the high surface and exhaust temperatures, adults and children must observe clearances to avoid burns or clothing ignition.
13. Operate only on a stable, level surface.
14. Do not use with ductwork. Do not restrict inlet or exit.
15. Use only the electrical power specified. The electrical connection and grounding must comply with National Electrical Code - ANSI/NFPA 70 (USA) and CSA C22.1 Canadian Electrical Code, Part 1 (Canada).
16. Use only a properly grounded 3-prong receptacle or extension cord.
17. Do not move, handle or service while hot or burning.
18. Use only in accordance with local codes or, in the absence of local codes, with the Standard for the Storage and Handling of Liquefied Petroleum Gases ANSI/NFPA 58 and CSA B149.1, Natural Gas and Propane Installation Code.

Figure 2

MINIMUM CLEARANCE: From normal combustible material

Clearance	Forced Air 400FAVT
From floor	0 ft
From outlet.....	8 ft
From sides	2 ft
From top	3 ft
Locate 10 ft. from canvas or plastic tarpaulins or similar coverings and secure them to prevent flapping or movement due to wind action.	

ODOR FADE WARNING



WARNING **Asphyxiation Hazard**

- Do not use this heater for heating human living quarters.
- Do not use in unventilated areas.
- The flow of combustion and ventilation air must not be obstructed.
- Proper ventilation air must be provided to support the combustion air requirements of the heater being used.
- Refer to the specification section of the heater's manual, heater dataplate, or contact the Factory to determine combustion air ventilation requirements of the heater.
- Lack of proper ventilation air will lead to improper combustion.
- Improper combustion can lead to carbon monoxide poisoning leading to serious injury or death. Symptom of carbon monoxide poisoning can include headaches dizziness and difficulty in breathing.

FUEL GAS ODOR

LP gas and natural gas have man-made odorants added specifically for detection of fuel gas leaks.

If a gas leak occurs you should be able to smell the fuel gas. Since Propane (LP) is heavier than air you should smell for the gas odor low to the floor. ANY GAS ODOR IS YOUR SIGNAL TO GO INTO IMMEDIATE ACTION!

- Do not take any action that could ignite the fuel gas. Do not operate any electrical switches. Do not pull any power supply or extension cords. Do not light matches or any other source of flame. Do not use your telephone.
- Get everyone out of the building and away from the area immediately.
- Close all propane (LP) gas tank or cylinder fuel supply valves, or the main fuel supply valve located at the meter if you use natural gas.
- Propane (LP) gas is heavier than air and may settle in low areas. When you have reason to suspect a propane leak, keep out of all low areas.
- Use your neighbor's phone and call your fuel gas supplier and your fire department. Do not re-enter the building or area.
- Stay out of the building and away from the area until declared safe by the firefighters and your fuel gas supplier.
- FINALLY, let the fuel gas service person and the firefighters check for escaped gas. Have them air out the building and area before you return. Properly trained service people must repair any leaks, check for further leakages, and then relight the appliance for you.

ODOR FADING - NO ODOR DETECTED

- Some people cannot smell well. Some people cannot smell the odor of the man-made chemical added to propane (LP) or natural gas. You must determine if you can smell the odorant in these fuel gases.
- Learn to recognize the odor of propane (LP) gas and natural gas. Local propane (LP) gas dealers will be more than happy to give you a scratch and sniff pamphlet. Use it to become familiar with the fuel gas odor.

- Smoking can decrease your ability to smell. Being around an odor for a period of time can affect your sensitivity to that particular odor. Odors present in animal confinement buildings can mask fuel gas odor.
- The odorant in propane (LP) gas and natural gas is colorless and the intensity of its odor can fade under some circumstances.
- If there is an underground leak, the movement of gas through the soil can filter the odorant.
- Propane (LP) gas odor may differ in intensity at different levels. Since Propane (LP) gas is heavier than air, there may be more odor at lower levels.
- Always be sensitive to the slightest gas odor. **If you continue to detect any gas odor, no matter how small, treat it as a serious leak. Immediately go into action as discussed previously.**

ATTENTION - CRITICAL POINTS TO REMEMBER!

- Propane (LP) gas has a distinctive odor. Learn to recognize these odors. (Reference Fuel Gas Odor and Odor Fading sections above)
- Even If you are not properly trained in the service and repair of the heater, ALWAYS be consciously aware of the odors of propane (LP) gas and natural gas.
- If you have not been properly trained in repair and service of propane (LP) gas then do not attempt to light heater, perform service or repairs, or make any adjustments to the heater or the propane (LP) gas fuel system.
- A periodic sniff test around the heater or at the heater's joints; i.e. hose, connections, etc., is a good safety practice under any conditions. If you smell even a small amount of gas, CONTACT YOUR FUEL GAS SUPPLIER IMMEDIATELY. DO NOT WAIT!

OPERATING INSTRUCTIONS

PREPARING FOR OPERATION

1. Check the heater for possible shipping damage. If any is found, immediately notify the factory.
2. Follow all of the "Precautions".
3. Connect the POL fitting of hose and regulator assembly to the propane cylinder by rotating the POL nut counterclockwise into the propane cylinder's valve outlet and securely tighten with a wrench.
4. Connect the hose to the heater by rotating the hose fitting clockwise.
5. Securely tighten all gas connections.
6. Open the cylinder's gas valve and check all gas connections with a soap and water solution. **DO NOT USE A FLAME.**
7. Connect power cord to well-grounded 115V, 60 Hz, 1Ø source of power.
8. When using an extension cord, make certain that it is a 3-wire (grounded) cord of proper wire size.

START

1. Slowly open the main valve at propane cylinder to prevent excess flow check valve from closing.
2. Set thermostat to full on. Heater will ignite automatically.
3. Adjust ball valve on control panel to desired burn rate.
4. Set thermostat to desired temperature. Heater will turn off and on automatically as the temperature varies in the heater area.

STOP

1. Securely close valve on the propane cylinder.
2. Continue to operate heater until all fuel in the hose has burned.
3. Unplug the heater from electrical supply.

CAUTION Failure to unplug the unit may result in unexpected operation.

RESTART AFTER SAFETY SHUTDOWN

1. Securely close valve at propane cylinder. Unplug heater.
2. Wait 5 minutes.
3. Restart following "Start" procedure.

MAINTENANCE AND STORAGE

1. The heater should be inspected before each use, and at least annually by a qualified person.
2. Before each use, check the soft "O" ring seat at the bullnose of the POL fitting. If the "O" ring is cut, scuffed, or otherwise damaged, replace it with part number F273786.
3. Turn off the gas at the LP-gas supply cylinder(s) when the heater is not in use.
4. When the heater is to be stored indoors, the connection between the LP-gas supply cylinder(s) and the heater must be disconnected and the cylinder(s) removed from the heater and stored out of doors and in accordance with Chapter 5 of the standard for Storage and Handling of Liquefied Petroleum Gases ANSI/NFPA 58 and CSA B149.1, Natural Gas and Propane Installation Code.

SERVICING

A hazardous condition may result if a heater is used that has been modified or is not functioning properly.

When the heater is working properly:

- The flame is contained within the heater.
- The flame is essentially blue with perhaps some yellow tipping.
- There is no strong disagreeable odor, eye burning or other physical discomfort.
- There is no smoke or soot internal or external to the heater.
- There are no unplanned or unexplained shut downs of the heater.

The parts lists and wiring diagram show the heater as it was constructed. Do not use a heater which is different from that shown. In this regard, use only the hose, regulator and cylinder connection fitting (called a POL fitting) supplied with the heater. **IMPORTANT** Match the color stripe on the hangtag attached to the hose assembly with the color on the label located near the propane inlet fitting on the heater. Do not use alternates. For this heater, the regulator must be set as shown in "specifications". If there is any uncertainty about the regulator setting, have it checked.

A heater which is not working right must be repaired, but only by a trained, experienced service person.

In-warranty products will be repaired with no charge for either parts or labor. Please include a brief statement indicating date, place of purchase, the nature of the problem and proof of purchase.

Out-of-warranty products will be repaired with a charge for parts and labor.

SIZE AND CAPACITY OF PROPANE CYLINDERS

The charts below show the approximate size of the cylinder required for these heaters. To use the chart:

1. Select the lowest air temperature expected (at the bottom of the chart).
2. Move straight up to time of operation desired (left side of the chart).
3. Read the cylinder size required.

All heaters should have:

Full cylinders with good air circulation and no frost on cylinders

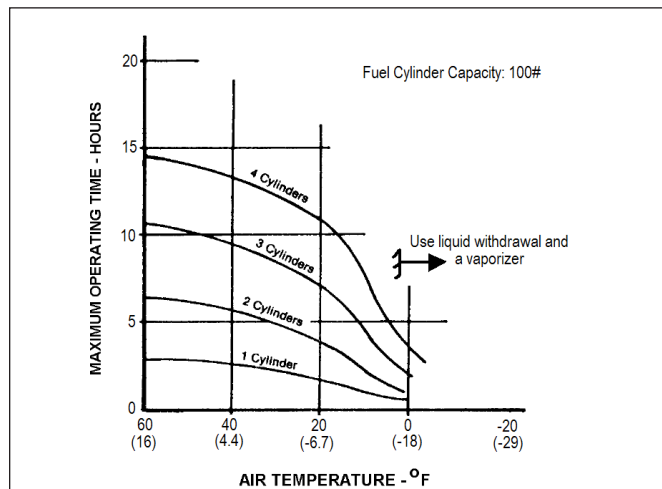

NEVER LEAVE THE HEATER UNATTENDED WHILE BURNING!

HOW MUCH HEAT DO I REQUIRE?

For economy, it is important to match input heat to that required. But heat requirements often vary. For example, it usually takes a lot more heat to get things warm than it does to keep them that way. Likewise, outside air temperature usually changes during the day so you may need more heat at night than you do in the daytime. An approximation of the heat required can be found by using the chart below.

BTU'S PER HOUR REQUIRED				
Cubic feet of space to be heated	Temperature Rise Required (°F)*			
	20°	30°	40°	50°
5,000	14,000	20,000	27,999	34,000
7,000	19,000	28,000	38,000	47,000
10,000	27,000	40,000	54,000	67,000
15,000	40,000	60,000	80,000	100,000
20,000	54,000	80,000	107,000	133,000
30,000	80,000	120,000	160,000	200,000
50,000	133,000	200,000	266,000	333,000

WARNING: When using a thermostat controlled heater, its exit area should be protected from personnel and warnings posted of sudden startup.

Recommended Minimum Gauge for Cord Extensions

Wire Gauge Chart A.W.G.				
Name Plate 120V Amps.	Cord Length in Feet			
	25	50	100	150
5-6	18	16	14	12
6-8	18	16	12	10
8-12	18	14	12	10
10-12	16	14	10	8
12-14	16	12	10	8

400FAVT - WIRING CHART

PART NO.	COLOR	LENGTH	FROM	TO
1100	White	7"	Valve	Terminal connection
1040	Black	6"	On/Off Switch	Terminal connection
1226	Red-(Hi-Temp)	16 1/2"	High Limit Switch	Valve
1226	Red-(Hi-Temp)	16 1/2"	High Limit Switch	Terminal connection
1070	Orange	11"	Flame Control (Ignition)	Spark Plug
1959	Green	7"	Flame Control (Harness)	Ground
1959	Red	7"	Flame Control (Harness)	Terminal connection
1959	White	6"	Flame Control (Harness)	Terminal connection
1959	Black	6"	Flame Control (Harness)	Terminal connection

Model #400FAVT WIRING DIAGRAM

- COLOR CODE / LEGEND
- B BLACK
 - L BLUE
 - G GREEN
 - O ORANGE
 - R RED
 - W WHITE
 - T_ TERMINAL CONNECTION

If any original wiring as supplied by the heater must be replaced, it must be replaced with type AWG 105° C wire or its equivalent except as indicated (*type SF2-200, **SGI 250° C).

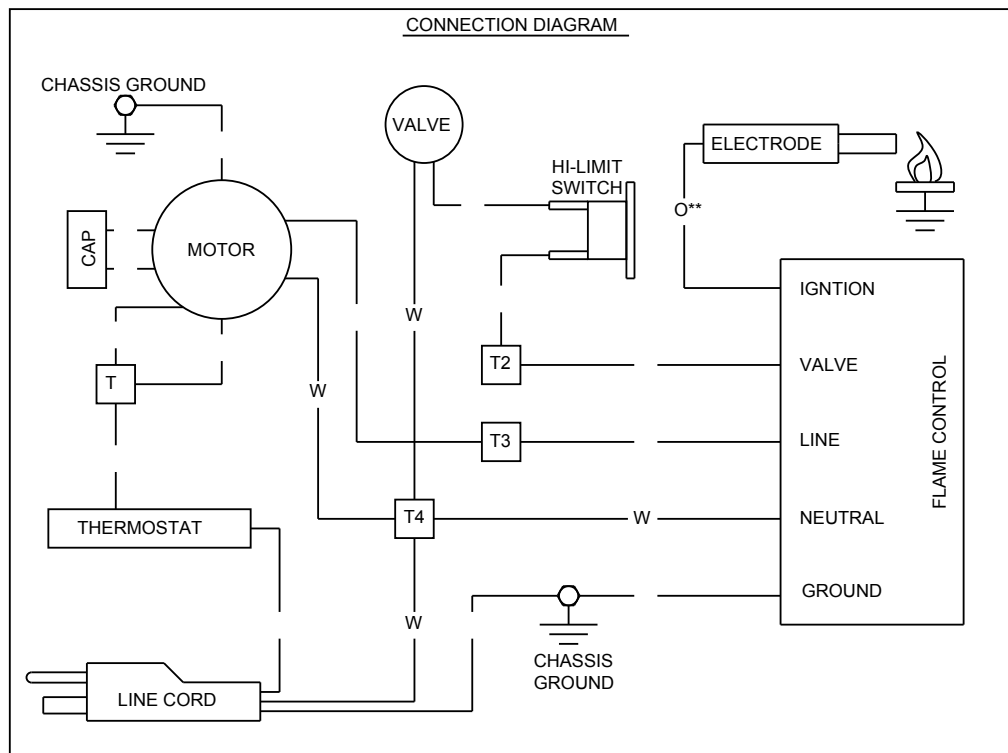

NEVER LEAVE THE HEATER UNATTENDED WHILE BURNING!

⚠WARNING

Air Quality Hazard

- Do not use this heater for heating human living quarters.
- Use of direct-fired heaters in the construction environment can result in exposure to levels of CO, CO₂, and NO₂ considered to be hazardous to health and potentially life threatening.
- Do not use in unventilated areas.
- Know the signs of CO and CO₂ poisoning.
 - Headaches, stinging eyes
 - Dizziness, disorientation
 - Difficulty breathing, feels of being suffocated
- Proper ventilation air exchange (OSHA 29 CFR 1926.57) to support combustion and maintain acceptable air quality shall be provided in accordance with OSHA 29 CFR Part 1926.154, ANSI A10.10 Safety Requirements for Temporary and Portable Space Heating Devices and Equipment used in the Construction Industry or the Natural Gas and Propane Installation Codes CSA B149.1.
 - Periodically monitor levels of CO, CO₂ and NO₂ existing at the construction site – at the minimum at the start of the shift and after 4 hours.
 - Provide ventilation air exchange, either natural or mechanical, as required to maintain acceptable indoor air quality.

	USA 8-Hr Time weighted average (OSHA 29 CFR 1926.55 App A)	Canada 8-hr time weighted average WorkSafe BC OHS Guidelines Part 5.1 and Ontario Workplaces Reg 833
CO	50 ppm	25 ppm
CO ₂	5000 ppm	5000 ppm
NO ₂		3 ppm (Reg 833)
	USA – Ceiling Limit (Short Term Exposure Limit = 15 minutes)	Canada STEL (15 minutes Reg 833/1 hour WSBC) WorkSafe BC OHS Guidelines Part 5.1 and Ontario Workplaces Reg 833
CO		100 ppm
CO ₂		15000 ppm (WSBC) 30000 ppm (Reg 833)
NO ₂	5 ppm	1.0 ppm (WorkSafeBC) 5.0 ppm (Reg 833)

- Ensure that the flow of combustion and ventilation air exchange cannot become obstructed.
- As the building 'tightens up' during the construction phases ventilation may need to be increased.

Installation of this appliance at altitudes above 2000 ft (610 m) shall be in accordance with local codes, or in the absence of local codes, the National Fuel Gas Code, ANSI Z223.1/NFPA 54, or National Standard of Canada, Natural Gas and Propane Installation Code, CSA B149.1

The heater has been shipped from the factory set up for operation on propane gas.