

INSTALLATION INSTRUCTIONS

GAS KITS AND
ACCESSORIES

19M54

See unit nameplate for manufacturer
and address.

CONTROL BOARD CHANGEOVER KIT

INSTALLATION INSTRUCTIONS FOR GCI-3A (23L53) CONTROL BOARD CHANGEOVER KIT 19M54 FOR UNIT HEATERS AND DUCT FURNACES

WARNING

This conversion kit shall be installed by a qualified service agency in accordance with the manufacturer's instructions and all applicable codes and requirements of the authority having jurisdiction. If the information in these instructions is not followed exactly, a fire, an explosion or production of carbon monoxide may result causing property damage, personal injury or loss of life. The qualified service agency is responsible for the proper installation of this kit. The installation is not proper and complete until the operation of the converted appliance is checked as specified in the manufacturer's instructions supplied with the kit.

Installation

WARNING



Electric shock hazard. Can cause injury or death. Before attempting to perform any service or maintenance, turn the electrical power to unit OFF at disconnect switch(es). Unit may have multiple power supplies. Use a voltage meter to verify that there is no electrical power to the unit after the switch(es) is disconnected.

- 1- Set thermostat to lowest setting. The gas supply must be shut off prior to disconnecting the electrical power and proceeding with the conversion.
- 2- Turn automatic gas valve knob to OFF position.

- 3- **IMPORTANT:** Determine the model of the appliance and the style of the factory installed control board. The number of pins in the wiring harness connector plug of the board will identify the style of the control board. Count the number of pins in the connector plug and then proceed to the step-by-step instructions for that model appliance and style control board. There are different instructions depending upon the model of appliance and style of control board (number of pins on connector).

Shipping and Packing List

Package 1 of 1 contains:

- 1- GCI-3A (23L53) control board.
- 1- 9-pin/6-pin wiring harness adapter.
- 1- 15-pin/6-pin wiring harness adapter.
- 1- Wiring diagram label.
- 1- Burner box top for 30 and 45 compact models.
- 1- Burner box top for 60 and 75 compact models.
- 1- Control board mounting plate.
- 1- BROWN jumper wire.
- 1- GREEN/YELLOW + YELLOW ground wire assembly.
- 1- BLACK lead wire.
- 1- Ignitor wire.
- 1- Unit conversion sticker.

Application

This conversion kit is used to update electronic control boards in the following model unit heaters and duct furnaces that were originally factory equipped with either RAM-3MC5 (33J62), GCI-3 (43K49), or EGC-2 (73K80) control boards: LF24-series, LD24-series, UHPA series, CGHA series, SEP-series, HED-series, CUH series, and DULA series.

P/N: 065310301

ORIGINATED: 2/01

REVISED: 10/02

SUPERSEDES: 065310300

Installation for LF24-, CGHA-, CUH-, and DULA-COMPACT unit heaters with 9-pin connector boards (43K49).

WIRING DIAGRAM 1

- 1- Unplug the 9-pin plug from the factory installed control board.
- 2- Attach numbered wire markers to the following wires and write the wire number in the space provided as they are disconnected from the factory installed control board
 - BLUE 24 VAC hot wire...Wire # _____
 - GREEN/YELLOW + YELLOW GROUND wire..Wire # _____
 - Ignitor wire...Wire # _____
 - BLACK fan motor ACC wire...Wire # _____
 - BLACK L1 lead wire...Wire # _____
 - BLACK CMB BLWR blower wire...Wire # _____
- 3- Disconnect rollout limit switch(es).
 - For units with one rollout limit switch, disconnect the two brown wires.
 - For units with two rollout limit switches, disconnect the brown wire from each switch that originates from the 9-pin wiring harness. It is not necessary to remove the brown jumper wire that connects the two switches.
- 4- Remove the two screws that attach the transformer and GREEN/YELLOW ground wire to the burner box top cover. Lay the transformer aside, do not disconnect wiring from transformer.
- 5- Remove the six screws that attach the burner box top to the burner box.
- 6- Remove the four screws that attach the factory installed control board to burner box top cover.
- 7- Using three of the four screws removed in step 6, attach the new control board to the new burner box top cover. See **FIGURE 1**.
- 8- Remove the screws that attach the rollout limit switch(es) to the factory installed burner box top cover.
- 9- Using the screws removed in step 8, attach the rollout limit switch(es) to the new burner box top cover.
- 10- Using the six screws removed in step 5, attach the new burner box top cover to the burner box. See figure 1.
- 11- Using the two screws removed in step 4, attach the transformer and the GREEN/YELLOW ground wire to the new burner box top cover. See **FIGURE 1**.
- 12- Connect the 9-pin/6-pin wiring adapter to the plug connectors on the new control board and the factory installed 9-pin wiring harness.
- 13- Connect the following wires to the new control board using the wire number guide from step 2
 - BLUE wire # _____ from the transformer to the "24 VAC HOT" terminal
 - GREEN/YELLOW + YELLOW wire # _____ to the "GROUND" terminal
 - Ignitor wire # _____ to the "T1" terminal on the ignition coil
 - BLACK fan motor ACC wire # _____ to the "ACC" terminal
 - BLACK L1 lead wire # _____ to the "L1" terminal
 - BLACK CMB BLWR wire # _____ to the "CMB BLWR" terminal
 - WHITE flame sensor wire from the 9-pin/6-pin wiring adapter to the "FLAME" terminal.
14. Connect the rollout limit switch(es)
 - For units with one rollout limit switch connect the two brown wires from the factory installed 9-pin wiring harness to the switch.
 - For units with two rollout limit switches connect one of the two brown wires from the factory installed 9-pin wiring harness to each rollout limit switch.
15. Disconnect the ORANGE wire from the limit switch and cut it off close to the pressure switch making certain not to cut the other ORANGE wire that connects the pressure switch to the factory installed 9-pin wiring harness.
16. Connect the BLUE wire from the 9-pin/6-pin wiring adapter to the limit switch where the ORANGE wire was disconnected in step 15.
17. Connect the line neutral to the WHITE wire from the transformer "COM" terminal and to the neutral wire from each motor.
18. Connect the 120VAC line to the BLACK L1 lead wire from the control board and to the BLACK lead wire from the transformer "120V" terminal.
19. Affix the unit conversion sticker beside the rating plate label.
20. Proceed to the Start-Up section.

Installation for LF24, CGHA, and CUH-GOMPACT unit heaters with 15-pin connector boards (33J62).

WIRING DIAGRAM 2

- 1- Unplug the 15-pin plug from the factory installed control board.
- 2- Attach numbered wire markers to the following wires and write the wire number in the space provided as they are disconnected from the factory installed control board
 - BLUE 24 VAC hot wire...Wire # _____
 - BLACK LINE VAC HOT wire...Wire # _____
 - BLACK ACB HEAT fan motor wire...Wire # _____
- 3- Disconnect the following wires from the factory installed control board and from their other termination as noted. Discard these wires.
 - YELLOW 24 VAC RTN wire, also disconnect from the transformer
 - Ignitor wire, also disconnect from the spark ignitor in the burner box
 - BLACK LINE VAC TX wire, also disconnect from the transformer
 - WHITE LINE VAC RTN wire, also disconnect from the line neutral
 - GREEN ground wire, also disconnect from the case ground location by removing the screw that attaches both the transformer and the wire to the burner box top cover.
- 4- Remove the other screw that attaches the transformer to the burner box top cover. Set the transformer aside, do not disconnect the other transformer wires.
- 5- Disconnect the wire from the limit switch that connects the limit switch to the pressure switch (this wire may be ORANGE or BLUE). Cut this wire off close to the pressure switch making certain not to cut the ORANGE wire that connects the pressure switch to the factory installed 15-pin wiring harness.
- 6- Remove the four screws that attach the factory installed control board to the burner box top cover.
- 7- Using the four screws removed in step 6, attach the new control board to the control board mounting plate. Locate the control board so that the 6-pin connector is next to one of the mounting plate flanges and so that the thermostat connections are next to the other mounting plate flange. See **FIGURE 2**.
- 8- Connect the following wires to the new control board using the wire number guide from step 2
 - BLUE wire # _____ from the transformer to the "24 VAC HOT" terminal
 - BLACK LINE VAC HOT wire # _____ to the "L1" terminal.
 - BLACK ACB HEAT fan motor wire # _____ to the "ACC" terminal
- 9- Make the following new wiring connections
 - Connect the new BLACK lead wire to the "120V" terminal of the transformer.
 - BLACK wire from the 15-pin/6-pin wiring harness adapter to the "CMB BLWR" terminal
 - WHITE flame sensor wire with ¼" connector from the 15-pin/6-pin wiring adapter to the "FLAME" terminal
 - New Ignitor wire to the "T1" terminal of the ignition coil and also to the spark ignitor in the burner box
 - New GREEN/YELLOW + YELLOW ground wire to the "GROUND" terminal.
 - BLUE wire from the 15-pin/6-pin wiring harness adapter to the limit switch (replaces the wire removed in step 5).
- 10- Plug the 15-pin/6-pin wiring adapter to the control board and to the factory installed wiring harness.
- 11- Remove the screw that attaches the burner box top cover to the burner box at the corner nearest to the access panel. See **FIGURE 2**.
- 12- Using the screw removed in step 11, attach the control board mounting plate to the burner box. See figure 2.
- 13- Using the two screws removed from the transformer in steps 3 and 4, attach the transformer and control board mounting plate to the burner box top cover. Make certain that the new GREEN/YELLOW case ground wire is under one of these screws. See **FIGURE 2**.
- 14- Connect the new YELLOW ground wire to the "24VAC" terminal of the transformer.
- 15- Connect the three neutral wires to the line neutral. These wires include the WHITE wire from the 15-pin/6-pin wiring adapter, the neutral wire from the fan motor (BLACK wire marked with white tape), and the WHITE neutral wire from the transformer.
- 16- Connect the BLACK L1 wire from the control board and the new BLACK lead wire from the transformer to the 120VAC line.
- 17- Affix the unit conversion sticker beside the rating plate label.
- 18- Proceed to the Start-Up section.

Installation for LF24-, LD24-, UHPA-, SEP-, HED- and DUHA- COMMERCIAL unit heaters and duct furnaces with 9-pin connector boards (43K49 or 73K80).

WIRING DIAGRAM 3

- 1- Unplug the 9-pin plug from the factory installed control board.
- 2- Attach numbered wire markers to the following wires and write the wire number in the space provided as they are disconnected from the factory installed control board
 - BLUE 24 VAC hot wire...Wire # _____
 - GREEN/YELLOW + YELLOW GROUND wire...Wire # _____
 - Ignitor wire...Wire # _____
 - BLACK fan motor ACC wire...Wire # _____
 - BLACK L1 lead wire...Wire # _____
 - BLACK CMB BLWR wire...Wire # _____
- 3- Disconnect the ORANGE wire from the limit switch and cut it off close to the pressure switch making certain not to cut the other ORANGE wire that connects the pressure switch to the factory installed 9-pin wiring harness.
- 4- Remove the four screws that attach the factory installed control board to the control box. Using the four screws removed in step 4, attach the new control board to the control board mounting plate. See **FIGURE 3**.
- 5- Remove the bottom screw from the transformer and remove the bottom-right screw from the control box.
- 6- Using the screws removed in step 6, attach the control board mounting plate to the control box. One corner attaches under the transformer and the other corner attaches at the bottom-right corner of the control box. Make certain that the GREEN/YELLOW ground wire is attached under the transformer. See **FIGURE 3**.
- 7- Connect the 9-pin/6-pin wiring adapter to the plug connectors on the new control board and the factory installed 9-pin wiring harness.
- 8- Connect the following wires to the new control board using the wire number guide from step 2
 - BLUE wire # _____ from the transformer to the "24 VAC HOT" terminal
 - GREEN/YELLOW + YELLOW wire # _____ to the "GROUND" terminal
 - Ignitor wire # _____ to the "T1" terminal on the ignition coil
 - BLACK fan motor ACC wire # _____ to the "ACC" terminal
 - BLACK L1 lead wire # _____ to the "L1" terminal
 - BLACK CMB BLWR wire # _____ to the "CMB BLWR" terminal
 - WHITE flame sensor wire from the 9-pin/6-pin wiring adapter to the "FLAME" terminal.
- 9- Connect the BLUE wire from the 9-pin/6-pin wiring adapter to the limit switch where the ORANGE wire was disconnected in step 3.
- 10- Connect the line neutral to the WHITE wire from the transformer "COM" terminal and to the neutral wire from each motor.
- 11- Connect the 120VAC line to the BLACK L1 lead wire from the control board and to the BLACK lead wire from the transformer "120V" terminal.
- 12- Affix the unit conversion sticker beside the rating plate label.
- 13- Proceed to the Start-Up section.

Start-Up

BEFORE LIGHTING, smell all around the appliance area for gas. Be sure to smell next to the floor because some gas is heavier than air and will settle on the floor.

Use only your hand to push in or turn the gas control knob. Never use tools. If the knob will not push in or turn by hand, do not try to repair it, call a qualified service technician. Force or attempted repair may result in a fire or explosion.

IMPORTANT - Follow the lighting instructions provided on the unit. If lighting instructions are not available, see section below.

This unit heater or duct furnace is equipped with an automatic spark ignition system. **DO NOT** attempt to manually light burners on this appliance. Each time thermostat calls for heat, the burners will automatically be lit.

- 1- Make sure thermostat is set below room temperature and power is turned off to unit.
- 2- This appliance is equipped with an ignition device that automatically lights the burners. **DO NOT** try to light the burners by hand.
- 3- Set knob on gas valve to OFF. Do not force.
- 4- Wait 5 minutes to clear out any gas. If you then smell gas, immediately call your gas supplier from an outside phone. Follow the gas supplier's instructions. If you do not smell gas go to next step.
- 5- Set knob on gas valve to ON.
- 6- Turn on all electrical power to unit.
- 7- Set thermostat to desired setting.

NOTE - When unit is initially started, steps 1 through 7 may need to be repeated to purge air from gas line.

Ignition Control LED

Check the normal operation sequence of the ignition system after conversion. See instruction manual supplied with the unit.

The ignition control board contains a green LED that indicates the following:

TABLE 1
IGNITION CONTROL LED

LED	UNIT OPERATION
Slow Flash*	Normal Operation - No call for heat
Fast Flash	Normal Operation - Call for heat Current signal at FLAME terminal 0.6 to 1.0 microamps
2 Flashes	System lockout - failed to detect or sustain flame Current signal at FLAME terminal <0.6 microamps
3 Flashes	Pressure switch failed closed before CAB is energized or failed open after CAB is energized
4 Flashes	High limit or rollout switch open
5 Flashes	Flame sensed and gas valve not energized
Steady Off	Loss of power
Steady On	Ignition control failure

*When thermostat is placed in continuous fan mode LED will slowly flash.

MOUNTING CONTROL BOARD TO COMPACT
UNITS WITH FACTORY 9-PIN WIRING HARNESS

ATTACH
CONTROL
BOARD TO
BURNER
BOX TOP
(THREE
PLACES)

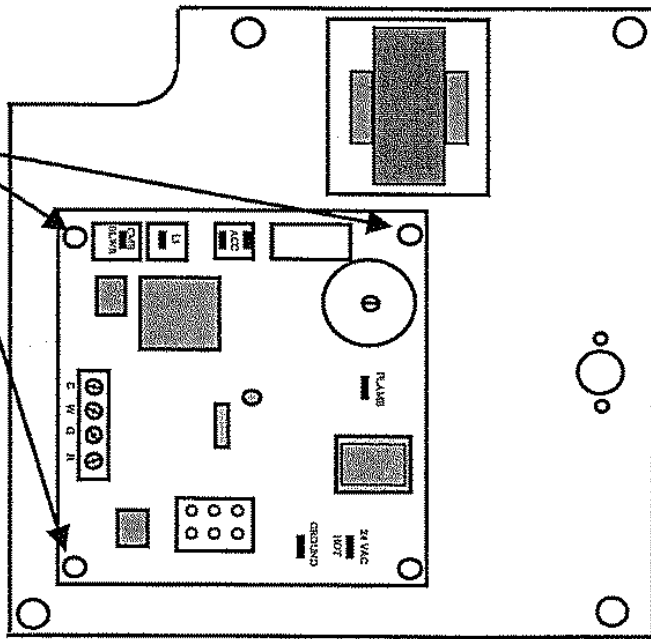

FIGURE 1

MOUNTING CONTROL BOARD TO COMPACT
UNITS WITH FACTORY 15-PIN WIRING HARNESS

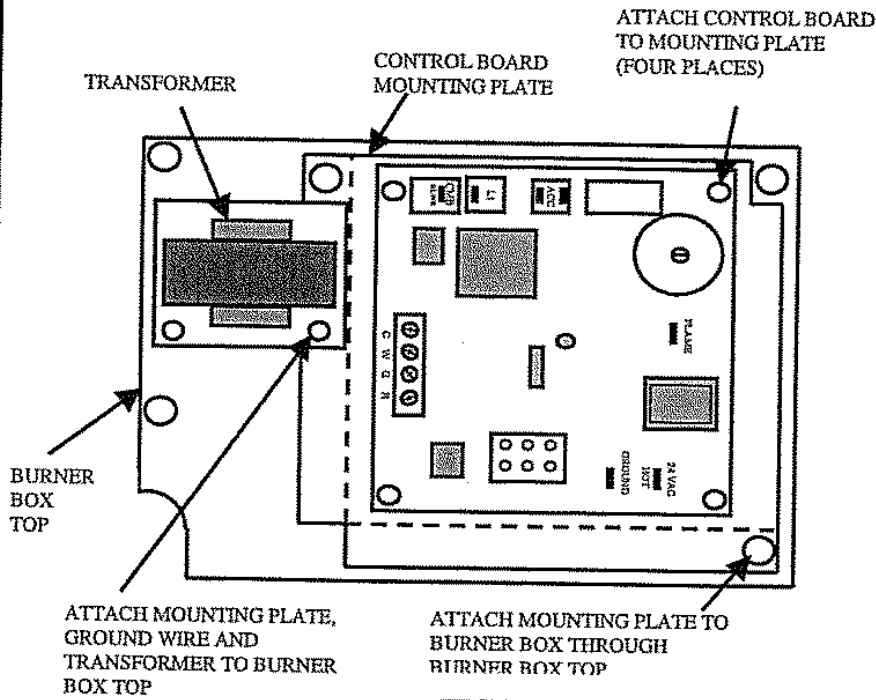

FIGURE 2

MOUNTING CONTROL BOARD TO COMMERCIAL
UNITS WITH FACTORY 9-PIN WIRING HARNESS

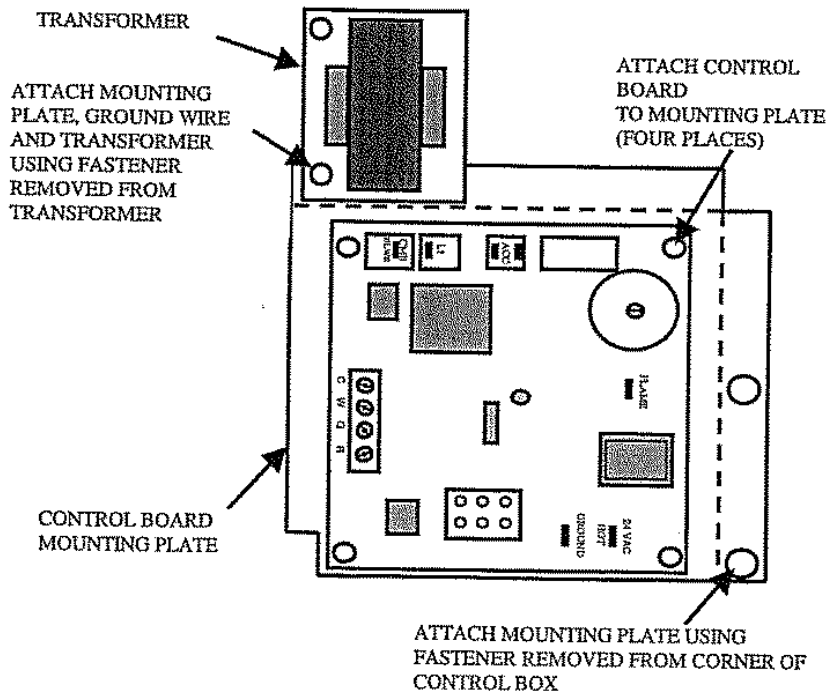
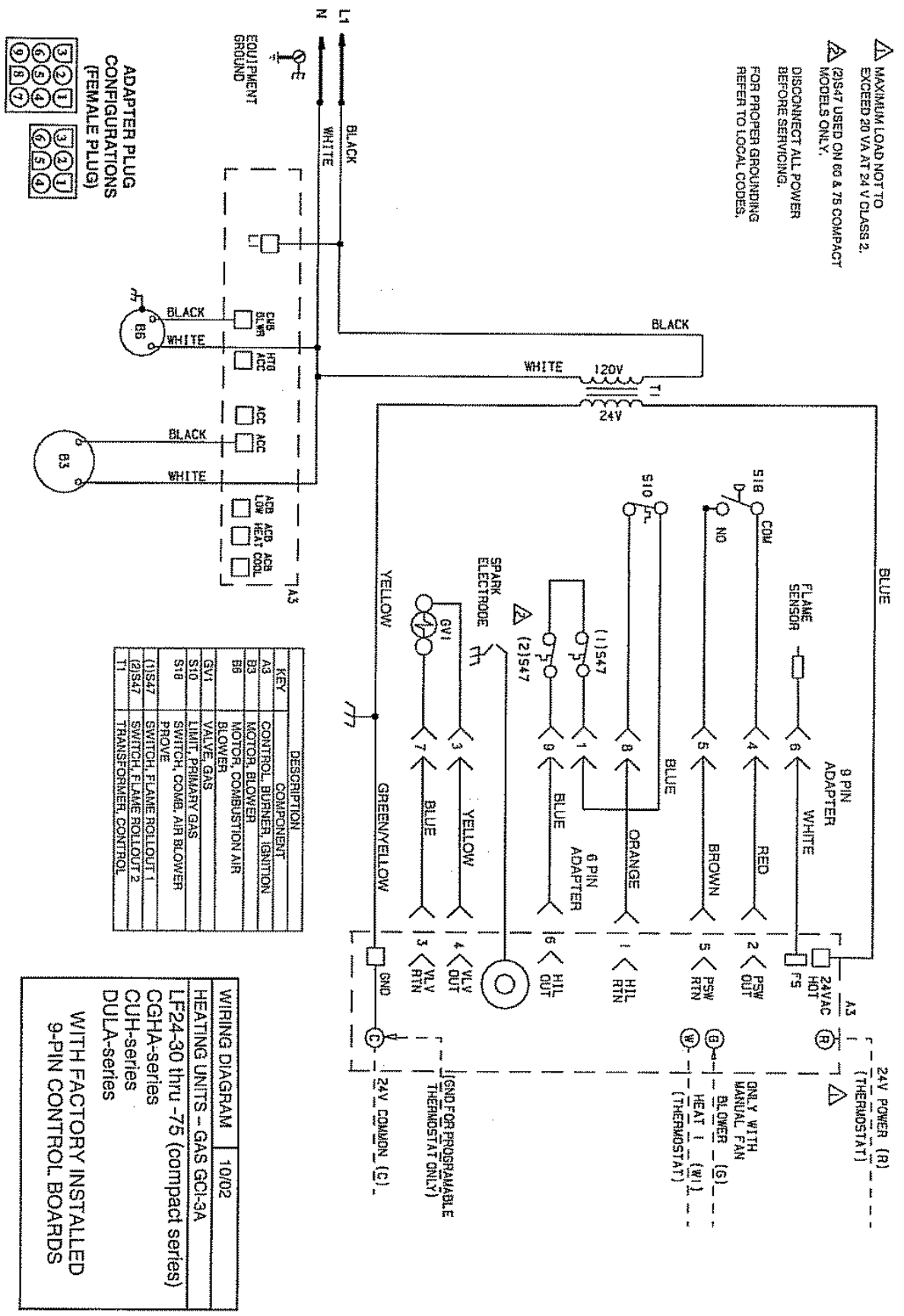

FIGURE 3

WIRING DIAGRAM 1

▲ MAXIMUM LOAD NOT TO EXCEED 20 VA AT 24 V CLASS 2.
 ▲ (2)S47 USED ON 60 & 75 COMPACT MODELS ONLY.
 DISCONNECT ALL POWER BEFORE SERVICING.
 FOR PROPER GROUNDING REFER TO LOCAL CODES.



WIRING DIAGRAM 2

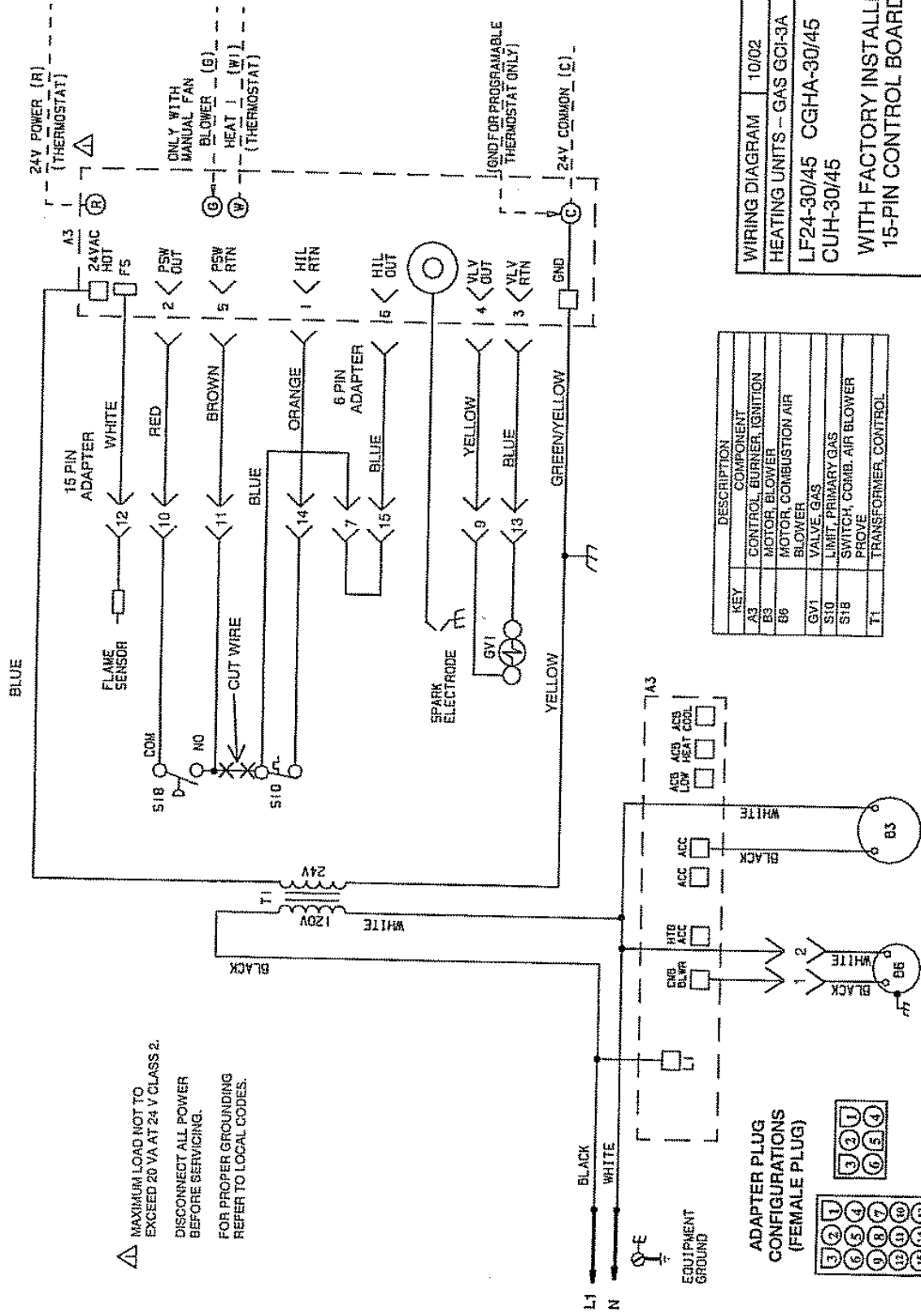

⚠ MAXIMUM LOAD NOT TO EXCEED 20 VA AT 24 V CLASS 2.
 DISCONNECT ALL POWER BEFORE SERVICING.
 FOR PROPER GROUNDING REFER TO LOCAL CODES.

KEY	DESCRIPTION
A3	CONTROL BURNER IGNITION
B3	MOTOR BLOWER
B6	MOTOR, COMBUSTION AIR BLOWER
GV1	VALVE, GAS
S10	LIMIT, PRIMARY GAS
S18	SWITCH, COMB. AIR BLOWER PROVE
T1	TRANSFORMER, CONTROL

WIRING DIAGRAM 10/02
 HEATING UNITS - GAS GCI-3A
 LF24-30/45 CGHA-30/45
 CUH-30/45
 WITH FACTORY INSTALLED 15-PIN CONTROL BOARDS

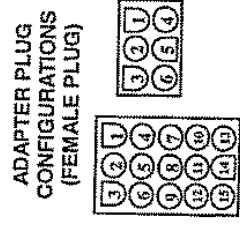

WIRING DIAGRAM 3

- ⚠ MAXIMUM LOAD NOT TO EXCEED 20 VA AT 24 V CLASS 2.
 - ⚠ C4 AND C10 USED ON 1/8 HP UNIT HEATER BLOWER MOTORS ONLY.
 - ⚠ B14 & S21 ONLY ON 230 THRU 400 SERIES UNIT HEATERS.
 - ⚠ S43 USED ON SEP-, UHPA, & LF24-100 THRU 150. (PROPANE ONLY)
 - ⚠ C2 ONLY USED ON 345 & 400 MODEL UNIT HEATERS.
- DISCONNECT ALL POWER BEFORE SERVICING.
FOR PROPER GROUNDING REFER TO LOCAL CODES.
- RELAY RATING: CIRCULATING BLOWER 1/4 HP @ 120 VAC IF A LARGER MOTOR IS TO BE USED, AN ADDITIONAL RELAY IS REQUIRED. (DUCT FURNACE)

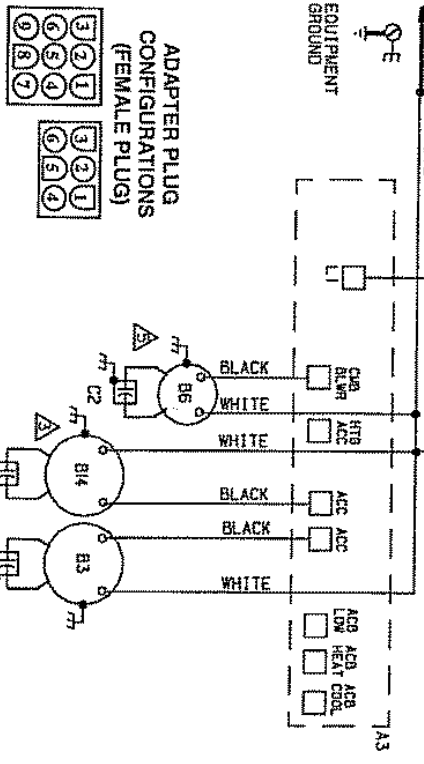
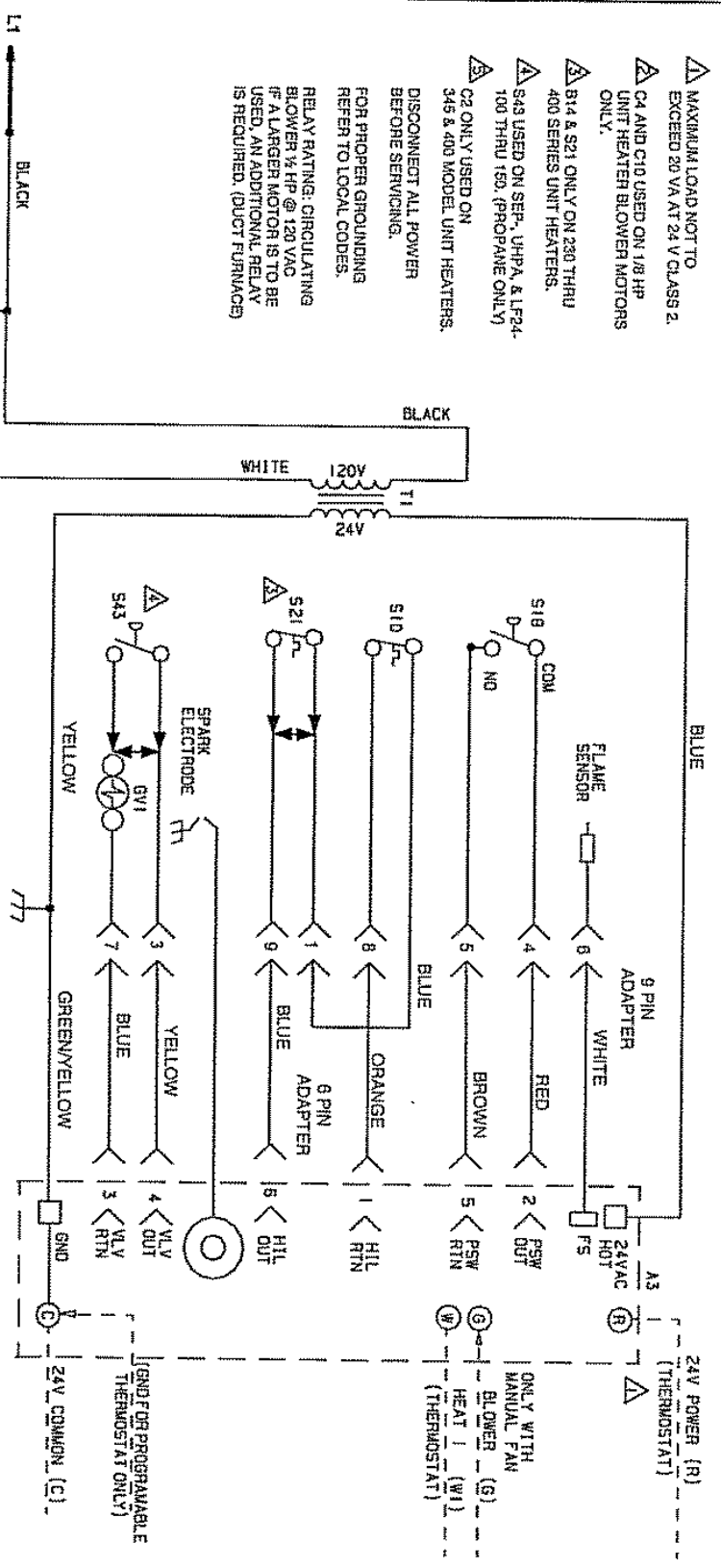

KEY	DESCRIPTION
A3	CONTROL, BURNER IGNITION
B3	MOTOR, BLOWER
B6	MOTOR, COMBUSTION AIR BLOWER
B14	MOTOR, BLOWER 2
C2	CAPACITOR, COMB. BLOWER
C4	CAPACITOR, BLOWER MOTOR 1
C10	CAPACITOR, BLOWER MOTOR 2
G1	VALVE, GAS
S10	LIMIT, PRIMARY GAS
S18	SWITCH, COMB. AIR BLOWER PROVE
S21	LIMIT, SECONDARY GAS HEAT
S43	SWITCH, LOW GAS PRESSURE
T1	TRANSFORMER, CONTROL

WIRING DIAGRAM	10/02
HEATING UNITS - GAS GCI-3A	
LF24-50 thru -400series	
LD24-series	
UHPA-series	
SEP-series	
HED-series	
WITH FACTORY INSTALLED 9-PIN CONTROL BOARDS	