

BRIZO®

BATHROOM FAUCETS

- Charlotte® Bath Collection
- Two Handle Wall-Mounted Lavatory

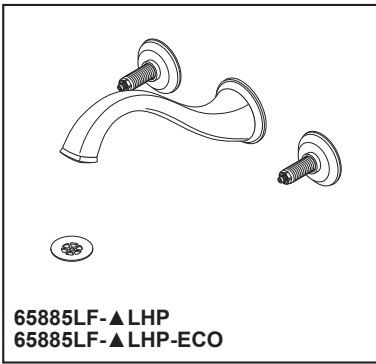





STANDARD SPECIFICATIONS:

- Max flow rate 1.5 gpm @ 60 psi, 5.7 L/min @ 414 kPa
- Max flow rate (ECO models only) 1.2 gpm @ 60 psi, 4.5 L/min @ 414 kPa
- Three-hole mount
- LHP - Less Handle Program. See handle options below.
- Control mechanism shall be of the rotating ceramic cylinder type with 90° (1/4 turn) rotation
- Recommend 1 1/2" hole size
- Metal grid strainer with overflow included (RP72412)
- Spout features laminar water flow

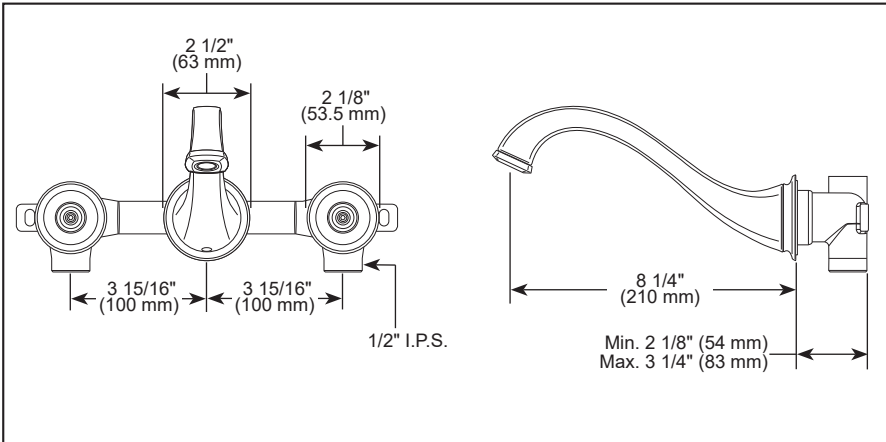
WARRANTY

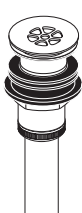
- Parts and Finish - Lifetime limited warranty; or for commercial purchasers, 10 years for multi-family residential (apartments and condominiums) and 5 years for all other commercial uses, in each case from the date the product is received by the original purchaser or their authorized representative (installation contractor, etc.).
- Electronic Parts and Batteries (if applicable) - 5 years from the date the product is received by the original purchaser or their authorized representative (installation contractor, etc.); or for commercial purchasers, 1 year from the date the product is received by the original purchaser or their authorized representative (installation contractor, etc.). No warranty is provided on batteries.
- Please go to www.brizo.com for the complete details of our limited warranty.

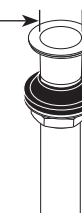

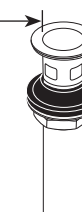
<p>RP72411▲ Grid Strainer Drain less overflow holes</p> 	<p>RP72413▲ Push Button Drain less overflow holes</p>  <p>2 3/4" (70 mm) Dia.</p>	<p>RP81627▲ Push Button Drain less overflow holes</p>  <p>1 5/8" (41 mm) Dia.</p>
<p>RP72412▲ Grid Strainer Drain with overflow holes (Included)</p> 	<p>RP72414▲ Push Button Drain with overflow holes</p>  <p>2 3/4" (70 mm) Dia.</p>	<p>RP81628▲ Push Button Drain with overflow holes</p>  <p>1 5/8" (41 mm) Dia.</p>



COMPLIES WITH:

- ASME A112.18.1 / CSA B125.1
- ASME A112.18.2 / CSA B125.2
- EPA WaterSense®
- ♿ ICC/ANSI A117.1 - Valve control only

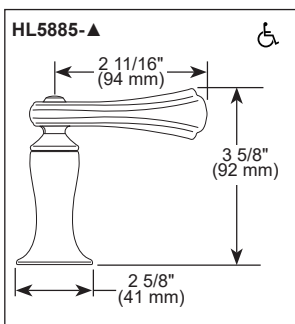

▲ Designate proper finish suffix

Brizo Kitchen & Bath Company reserves the right (1) to make changes in specifications and materials, and (2) to change or discontinue models, both without notice or obligation. Dimensions are for reference only. See current full-line price book or www.brizo.com for finish options and product availability.

BSP-L-65885LF-LHP Rev. F

Brizo Kitchen & Bath Company

55 E. 111th Street, Carmel, Indiana 46280
350 South Edgware Road, St. Thomas, ON N5P 4L1
© 2024 Brizo Kitchen & Bath Company