

see what Delta can do<sup>SM</sup>

## BATHROOM FAUCETS

- Trinsic<sup>®</sup> Bath Collection
- Two Handle Widespread Deck Mount

### FEATURES:

- DIAMOND Seal<sup>®</sup> Technology

### STANDARD SPECIFICATIONS:

- Max flow rate 1.2 gpm @ 60 psi, 4.5 L/min @ 414 kPa
- Three-hole mount
- Diamond coated ceramic cartridge
- 3/8" O.D. straight PEX supply tubes
- Red/blue indicator markings
- 1/4 turn handle stops
- Solid brass fabricated end valves
- Models have metal drain with pop-up type fitting with plated flange and stopper

### WARRANTY

- Parts and Finish - Lifetime limited warranty; or for commercial purchasers, 10 years for multi-family residential (apartments and condominiums) and 5 years for all other commercial uses, in each case from the date the product is received by the original purchaser or their authorized representative (installation contractor, etc.).
- Please go to [www.deltafaucet.com](http://www.deltafaucet.com) for the complete details of our limited warranty.



### COMPLIES WITH:

- ASME A112.18.1 / CSA B125.1
- ASME A112.18.2 / CSA B125.2
- NSF/ANSI/CAN 61 & 372
- EPA WaterSense<sup>®</sup>

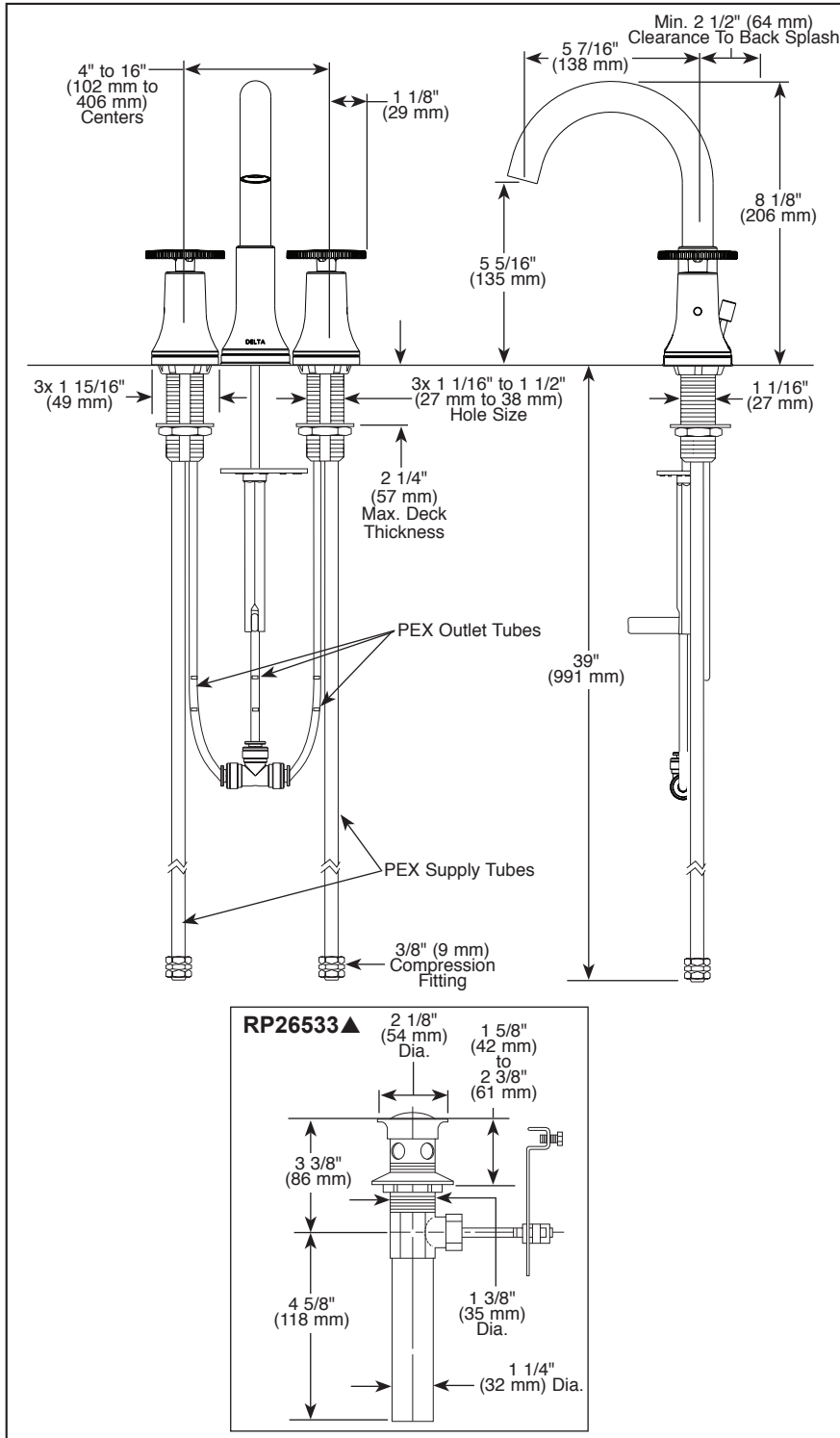

### ▲ Designate proper finish suffix

Delta Faucet Company reserves the right (1) to make changes in specifications and materials, and (2) to change or discontinue models, both without notice or obligation. Dimensions are for reference only. See current full-line price book or [www.deltafaucet.com](http://www.deltafaucet.com) for finish options and product availability.

DSP-L-3558-MPU-DST Rev. C

### Delta Faucet Company

55 E. 11th Street, Carmel, IN 46280  
 350 South Edgeware Road, St. Thomas, ON N5P 4L1  
 © 2025 Delta Faucet Company