

INSTALLATION INSTRUCTIONS - BATTERY FLUSHOMETER

(for Hardwire, skip to Step 3)

STEP 1 -

- Install battery flushometer to fixture.
- Open inlet stop.

STEP 2 -

- Follow instructions on yellow static label (Figure 4).
Note: The batteries are already installed and the product is in hibernation mode waiting to be activated.
- After you remove the yellow label, you must push the electronic override button three times within five seconds to activate the valve and to place it into operation mode. To signify the valve has entered operation mode, you will see an ascending and descending light sequence.
- Proceed to Step 5.

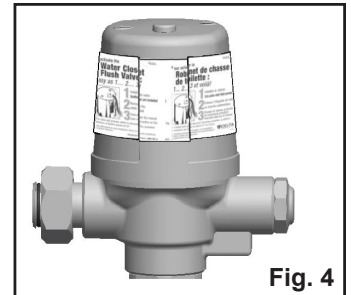

Fig. 4

INSTALLATION INSTRUCTIONS - HARDWIRED FLUSHOMETER

STEP 3 -

- Before installing the flush valve body, install 2" x 4" electrical box into wall with centre of box in line with the cut-out in the back of the metal flush valve cover. See Figure 5.
- Securely attach box to wall structure. ⚠ Install CSA and/or UL approved Class 2 transformer or equivalent in a convenient location or in a pipe chase. **(Do NOT install the transformer inside the control box.)** Run suitable wires from 24 VAC step down transformer into the electrical box. The transformer is to be installed in an adjacent accessible space. Use cable which complies to local electrical codes for 1 amp load. No. 18 cable is usually sufficient.
- Assemble plastic bushing into the hole on the coverplate.
- Measure and cut tube assembly to appropriate length so that the bushing will fit under the metal flush valve cover and the free end will protrude into the box through the coverplate by 1/2" minimum. Rotate cover gasket, if necessary, so that the U-shaped wire guides align with the rear opening in valve cover.
- Assemble flush valve to fixture. When ready, remove metal cover and feed the wires from the hardwire converter through the tube assembly and the tube assembly through the bushing on the coverplate.
- Attach the converter wires to the 24 VAC wires from a step down transformer.
- With power to the flushometer, you will see an ascending and descending light sequence to signify that the valve is now in operation mode.
- Assemble coverplate using the bracket and screws provided.
- With the tube bushing located in position, assemble metal cover to flush valve body with tube assembly located in metal cover cut-out.

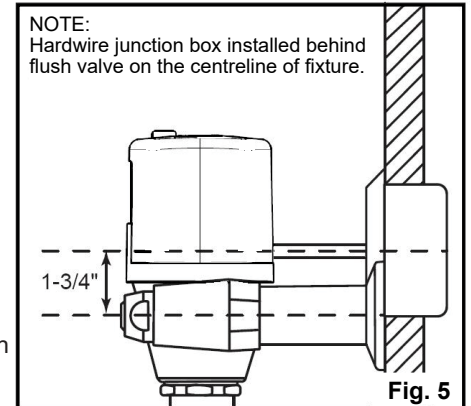

Fig. 5

STEP 4 -

- Open inlet stop.

STEP 5 -

- Upon power up - a sequence of descending and ascending red lights will signify that the valve is in operation mode.
- Once in operation mode, if factory settings are preferred, no further action is required and the valve installation is complete.

Factory pre-set functions are:

Water closet bowl length of 24", 24 hour flush is off.
Urinal sensing distance of 16", 24 hour flush is off.

MAKING ADJUSTMENTS TO THE ELECTRONIC FEATURES

(Optional: Only required if factory settings are not preferred)

Once in operation mode, if adjustments are preferred, installer must move into set up mode.

If desired adjustments are not made within 30 minutes of initial power-up, the power must be disconnected for 10 seconds and then reconnected to obtain another adjustment period.

STEP 6 -

- If 30 minutes have passed since the initial power-up of the valve - open up the battery compartment (Figures 9 and 10) and disconnect the battery snap for 10 seconds. Reconnect and replace the cover and screws. If hardwired - disconnect battery snap to the hardwire converter for 10 seconds.
- To move from operation mode into set-up mode, push and hold electronic override button for five seconds. Release the electronic override button when a solid blue light is visible.
- The water closet flushometer models have 2 settings which are adjustable via the Set-Up Mode - Bowl Length Selection and 24 Hour Flush Adjustment.
- The urinal flushometer models have 2 settings which are adjustable via the Set-Up Mode - Range Adjustment and 24 Hour Flush Adjustment.
- While in Set-Up Mode, the user will move through the different adjustment modes one by one, in the order as described above. Use the electronic override button to toggle through the different settings of the adjustment feature being altered. To advance to the next adjustment mode, hold down electronic override button until blue light is present, then release the button. See Figure 6.

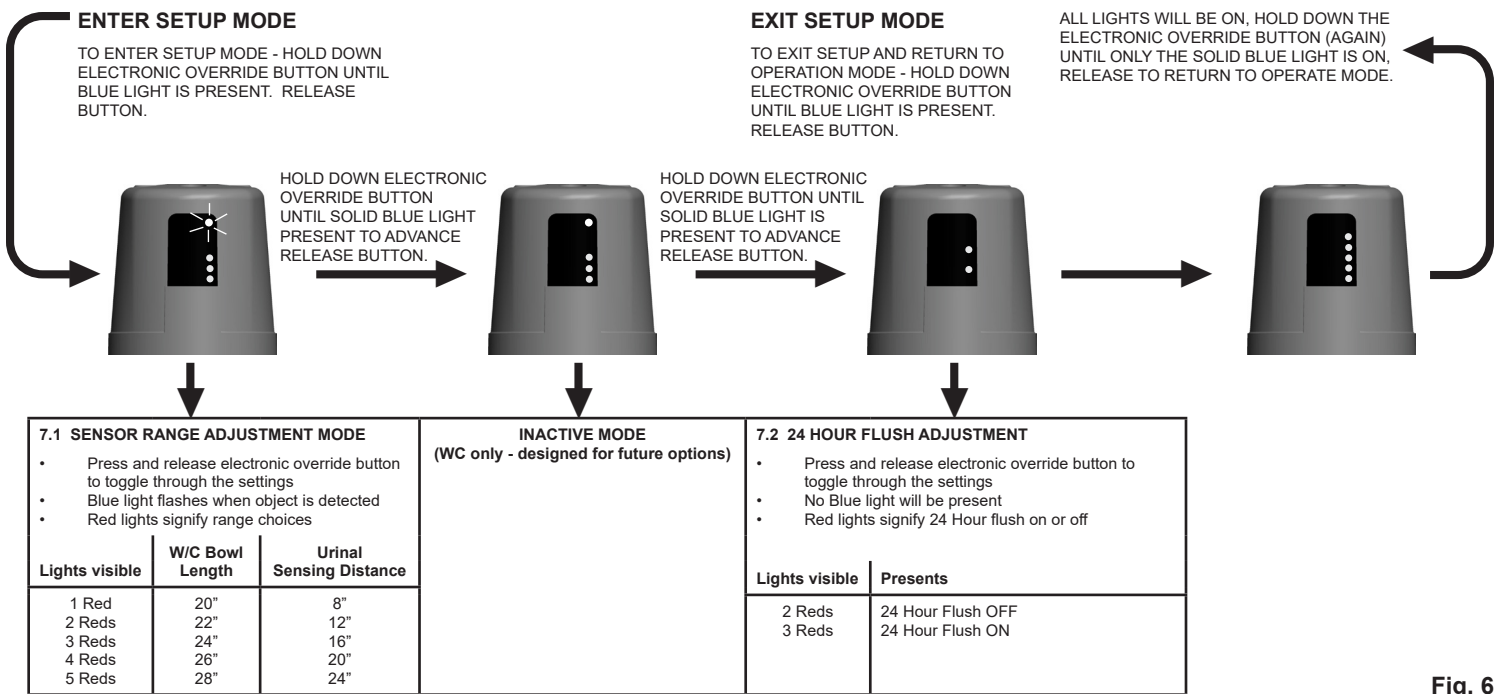

Fig. 6

Step 7: Making Adjustments (Optional: Only required if factory settings are not preferred)

7.1 Sensor Adjustment:

For Waterclosets:

- Configure the sensing ranges by selecting the appropriate bowl length. Refer to Figure 6 for the different bowl length settings.
- The bowl length is the distance from the centre line of the valve to the lip of the bowl (see Figure 7).
- To ensure the correct distance is selected, stand or place a target at the end of the bowl. Starting with one illuminated red light, step through the distances until the blue light begins to flash. The flashing light confirms that the sensor is configured for that bowl length.
- NOTE:** The W/C bowl length setting is **NOT** the sensing range. The advanced sensor activated flush system uses multiple detection distances and the bowl length to react appropriately to different usage patterns.
- If no further length adjustments are desired, press and hold down the electronic override button for 5 seconds, until a solid blue light is present. Release the electronic override button to advance to the next adjustment feature.
- A blue and red light will be present. This mode is currently inactive and is designed for any future options.
- To advance to the 24 Hour Flush, press and hold down electronic override button for 5 seconds until the solid blue light is present.
- Release electronic override button, you are now in 24 Hour Flush configuration.

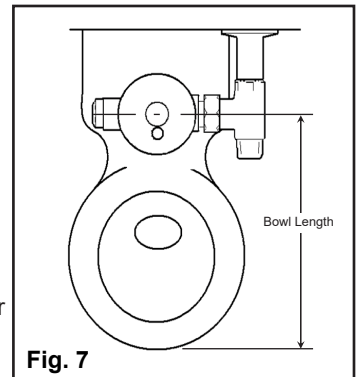

Fig. 7

For Urinals:

- Configure the sensing range by selecting the desired detection distance.
- Each press and release of the electronic override button advances to the next length/distance. (See Figure 6 for a list of distances)
- Start with one red visible light.
- Stand or place a target at the desired detection distance, the top blue light will be flashing if an object is detected.
- Press and release electronic override button to step through the distance options until the blue light begins to flash, indicating that the target has been detected. The blinking blue light indicates that the sensor is configured for that length/distance.
- The sensor is now set at your desired configuration.
- If no further sensing range adjustments are desired, press and hold down the electronic override button for 5 seconds, until a solid blue light is present.
- Release electronic override button. You are now in 24 Hour Flush configuration.

7.2 24 Hour Flush Adjustment Mode:

- When the 2 red lights are present - 24 hour flush is OFF.
- When the 3 red lights are present - 24 hour flush is ON.
- Press electronic override button to toggle between ON and OFF mode.

Exiting Set-Up Mode:

- Can be accomplished in one of two ways;
 - During the 24 Hour Adjustment feature, press and hold down electronic override button for 5 seconds until solid blue light is present. Release electronic override button. All lights will be ON. Press and Hold the electronic override button (again) until JUST the solid blue light is on, release the electronic override button.
 - During all modes, valve will revert back to operation mode automatically if the electronic override button is not pressed within 3 minutes.

* After the last adjustment has been completed and the flush valve has returned to operation mode, there is a window of approximately 30 minutes where additional changes can be made. If desired adjustments are not made within 30 minutes, the batteries or hardwire converter must be disconnected for 10 seconds and then re-connected to obtain another adjustment period. To make changes, begin at step #6 above.

BATTERY STRENGTH INDICATOR & BATTERY REPLACEMENT

TO CHECK BATTERY STRENGTH:

1. During Operation Mode - press and hold down the electronic override button for approximately 10 seconds.
2. DO NOT RELEASE BUTTON WHEN SOLID BLUE LIGHT IS PRESENT - KEEP HOLDING DOWN.
3. After 10 seconds, the battery strength will be displayed via the red lights. The more lights that are present, the more life the batteries have. See Figure 8.

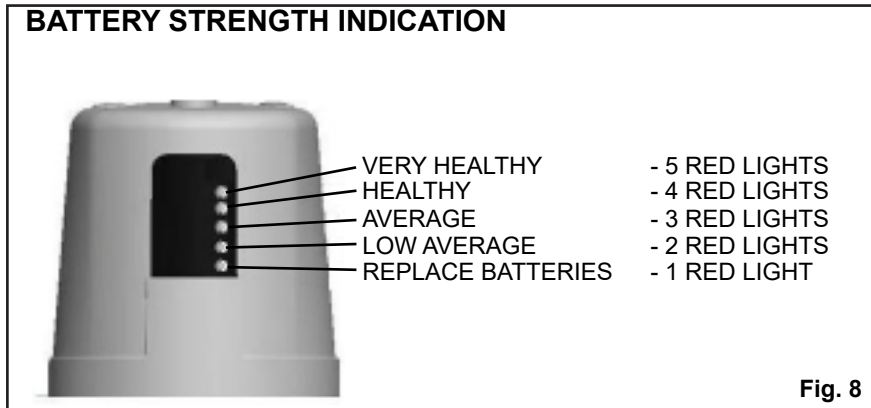

4. When you are satisfied with the strength indication, release the electronic override button to return to Operation mode.

TO REPLACE BATTERIES:

1. Remove the two cover screws and lift off metal cover, see Figure 9.
2. Hold case/cover securely with one hand and open hinged lid of the battery compartment in the back of the unit.
3. Pull the battery holder out and insert new set of four "AA" batteries into battery holder. (Use the +/- signs on the batteries and the +/- signs on the battery holder for correct positioning.)
Note: Do not use a metal screwdriver to remove snap from battery holder.
4. Install the refreshed battery holder back into the electronic housing. (When the new batteries are installed and connected, an initial ascending and descending red light sequence will occur.)
5. Close the battery compartment lid ensuring wires are neatly tucked into compartment and are not pinched between case and cover. Test the electronic override button. Blue light flashes once when override is activated.
6. Place the metal cover back onto flushometer and replace the two cover screws. DO NOT OVERTIGHTEN. Flushometer is now ready for use.

NOTE: All previously adjusted settings will be retained when batteries are changed.

1. **Start-Up:** When batteries are first inserted, there is an initial ascending and descending red light sequence that will occur.
2. **Electronic Override Button in Operating Mode:** Blue light flashes once when Electronic Override Button is activated.
3. **Low Battery Level Indicator:** One RED light flashes every 15 seconds, indicating approximately 5,000 flushes remain from when RED light first started flashing.

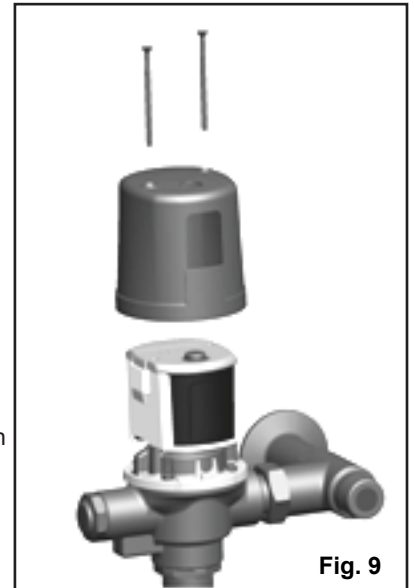

Fig. 9

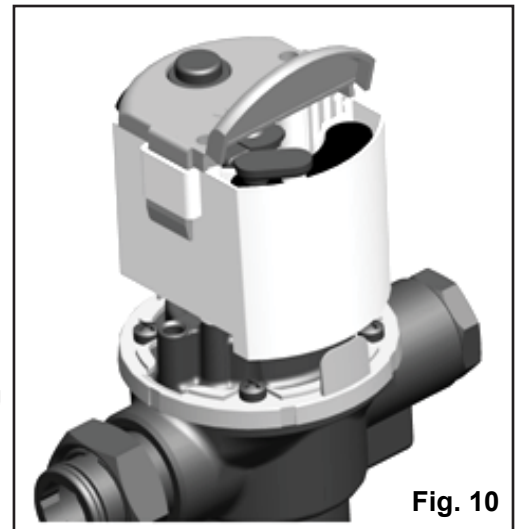

Fig. 10

MMO (Manual Mechanical Override)

This feature is intended for use by Maintenance staff for flushing the valve in the event of a battery failure.

Note: This option does not include a "Non Hold Open" feature. see Figure 11.

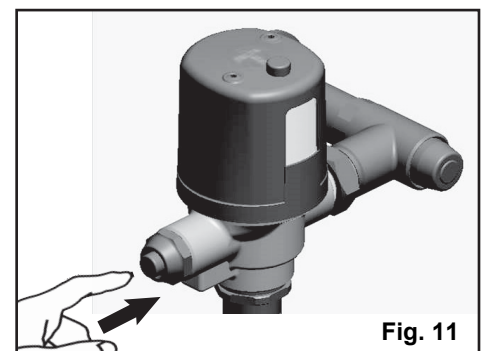

Fig. 11