



see what Delta can doSM

102028



X00102028

**TWO HANDLE WASHERLESS
BATHROOM FAUCET**
**LLAVE DE LAVAMANOS
DE DOS MANIJAS SIN ARANDELAS**
**ROBINET SANS RONDELLE À
DEUX MANETTES POUR LAVABO**

Model/Modelo/Modèle
25789LF ▲
Series/Series/Seria

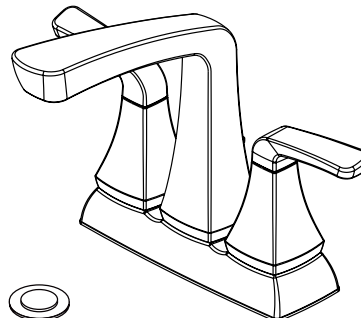

Write purchased model number here.
Escriba aquí el número del modelo comprado.
Inscrivez le numéro de modèle ici.

▲ Specify Finish/Especifique el Acabado/Précisez le Fini

Register Online
Regístrese en línea
S'enregistrer en ligne
www.deltafaucet.com/registerme

To reference replacement parts and access additional technical documents and product info, visit www.deltafaucet.com

Para referencia sobre las piezas de repuesto y acceder a documentos técnicos adicionales e información del producto, visite www.deltafaucet.com

Pour obtenir la référence des pièces de rechange ainsi que pour avoir accès à d'autres documents techniques et renseignements sur le produit, allez à www.deltafaucet.com



1-800-345-DELTA (3358)
customerservice@deltafaucet.com

Read all instructions prior to installation.

CAUTION

Failure to read these instructions prior to installation may result in personal injury, property damage, or product failure. Manufacturer assumes no responsibility for product failure due to improper installation.

Lea todas las instrucciones antes de hacer la instalación.

ADVERTENCIA

El no leer estas instrucciones de instalación puede resultar en lesiones personales, daños a la propiedad, o falla en el funcionamiento del producto. El fabricante no asume ninguna responsabilidad por la falla del producto debido a una instalación incorrecta.

Veillez lire toutes les instructions avant l'installation.

AVERTISSEMENT

L'omission de lire les présentes instructions avant l'installation peut entraîner des blessures, des dommages matériels ou le bris du produit. Le fabricant se dégage de toute responsabilité à l'égard d'un bris du produit causé par une mauvaise installation.

You may need:
Usted puede necesitar:
Articles dont vous pouvez avoir besoin :

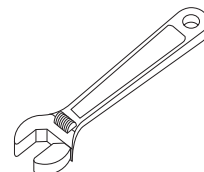
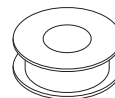
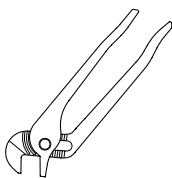
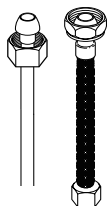

1

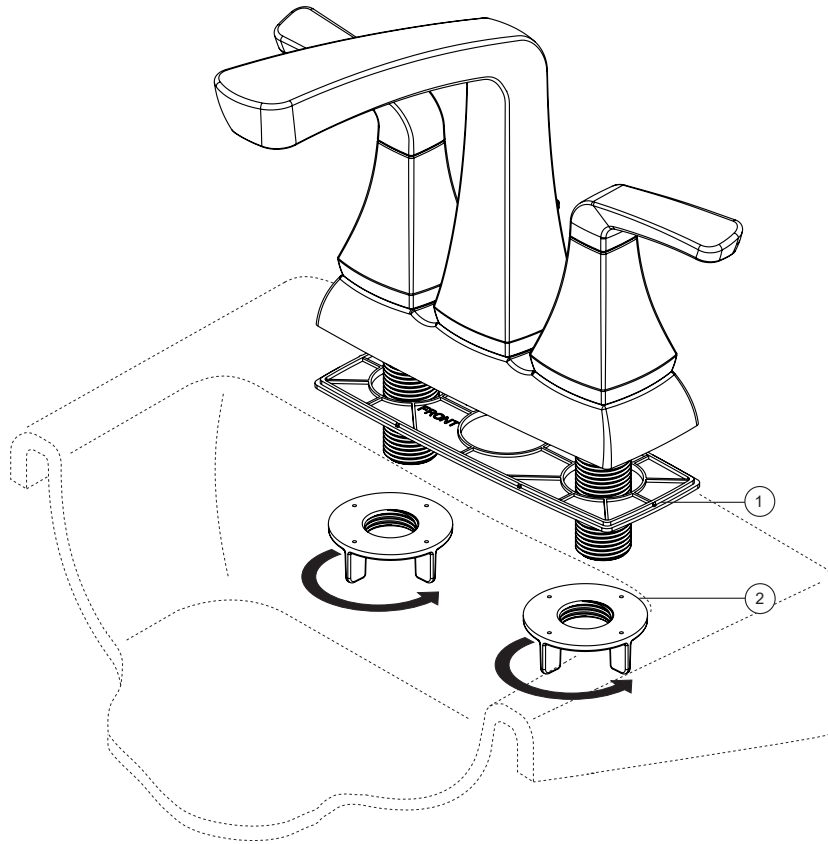

SHUT OFF WATER SUPPLIES.

Remove old faucet. Place gasket (1) on bottom of new faucet. Place faucet through mounting holes in sink.

Option: If sink is uneven, use silicone under the gasket (1).

Secure faucet to sink using locknuts (2) provided.

CIERRE LOS SUMINISTROS DE AGUA.

Quite la llave vieja. Coloque el empaque (1) en la parte inferior de la llave. Coloque la llave de agua a través de los agujeros de instalación en el lavamanos.

Opción: Si el lavamanos está desnivelado, utilice silicón debajo del empaque (1).

Fije la llave al lavamanos con las contratuercas (2) proporcionadas.

INTERROMPEZ L'ARRIVÉE D'EAU.

Déposez le vieux robinet. Placez le joint (1) contre le dessous du robinet neuf.

Option: Si la surface du lavabo est inégale, appliquez du composé à la silicone sous le joint (1).

Fixez le robinet l'évier à l'aide des écrous autofreinés (2) fournis.

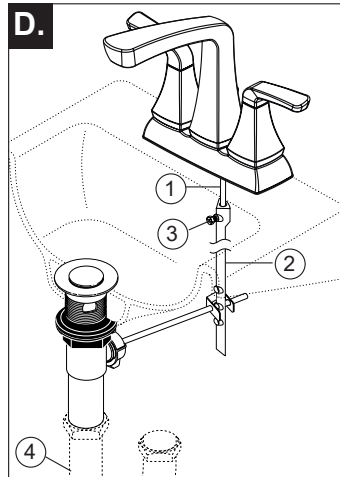
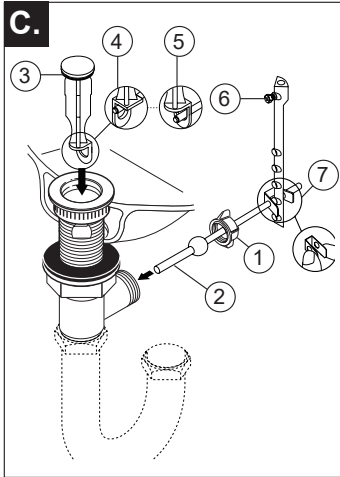
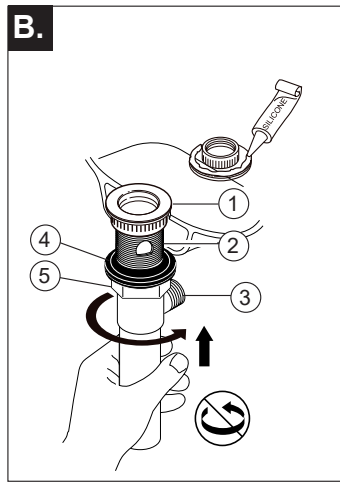
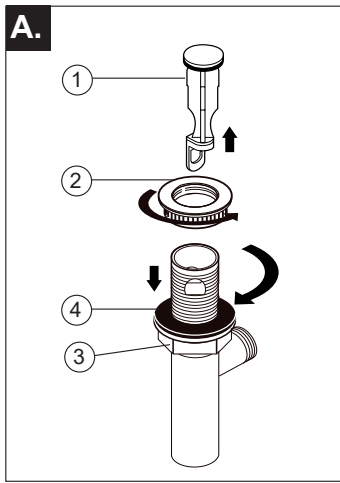
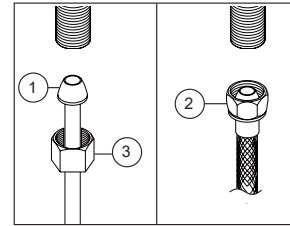
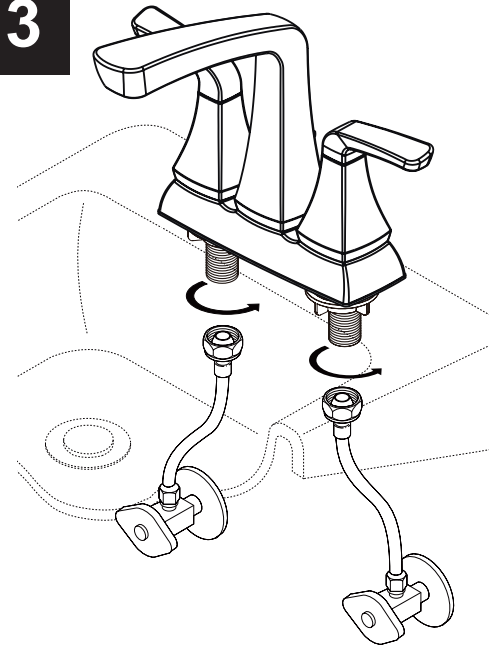
2**3****Install Pop-Up Assembly**

- A.** Remove stopper (1) and flange (2). Screw nut (3) all the way down. Push black gasket (4) down.
- C.** Remove pivot nut (1). Install horizontal rod (2) and stopper (3) as removable (4) or non-removable (5). Hand tighten pivot nut. Attach horizontal rod to strap (6) using clip (7).

- B.** Apply silicone to underside of flange (1). Screw body (2) onto flange and hand tighten. With pivot (3) facing toward faucet, secure gasket (4) and nut (5). **DO NOT TURN FLANGE WHILE TIGHTENING NUT OR SEALANT MAY NOT SEAL DRAIN.** Remove excess sealant.
- D.** Insert lift rod (1) through faucet and into strap (2). Tighten screw (3). Connect assembly to drain (4).

CONNECT TO WATER SUPPLIES. (HOOK-UPS NOT PROVIDED).

Determine which type of connection you will be making.
Ball nose risers (3/8" O.D. copper tubing) (1) with coupling nuts (3) (not supplied) or 1/2" I.P.S. faucet connectors (2).

Instale el Ensamble de Desagüe Automático

- A.** Quite el tapón (1) y el borde (2). Atornille la tuerca (3) completamente hasta abajo. Empuje el empaque negro (4). Poussez le joint noir (4) vers le bas.
- C.** Quite la tuerca del pivote (1). Instale la barra horizontal (2) y el tapón (3) como desmontable (4) o fijo (5). Apriete a mano la tuerca del pivote. Una la barra horizontal a la barra chata (6) utilizando el gancho (7).

- B.** Aplique silicón a la parte interior del reborde (1). Atornille el cuerpo (2) en la brida y apriete a mano. Con el pivote (3) de frente a la llave, hale el desagüe automático directamente hacia abajo dentro del drenaje y fije el empaque (4) y la tuerca (5). **NO GIRE EL DRENAJE AUTOMÁTICO MIENTRAS APRIETE LA TUERCA DE BRONCE O EL SELLADOR PUEDA NO SELLAR EL DRENAJE.** Quite el exceso de sellador.
- D.** Introduzca la barra de alzar (1) a través de la llave y dentro en la barra chata (2). Apriete el tornillo (3). Conecte el ensamble al desagüe (4).

CONECTE A LOS SUMINISTROS DE AGUA. (LAS CONEXIONES NO SON PROPORCIONADAS).

Determine que tipo de conexión usted va a hacer.
Tubos montantes de nariz redondeada (tubería de cobre de 3/8" D.E.) (1) con tuercas de acoplamiento (3) (no proporcionadas), o conectadores de llave I.P.S. de 1/2" (2).

Installez le renvoi mécanique

- A.** Enlevez la bonde (1) et la collerette (2). Vissez l'écrou (3) à fond. Poussez le joint noir (4) vers le bas.
- C.** Enlevez l'écrou de pivot (1). Installez la tige horizontale (2) et la bonde (3) pour qu'elle soit amovible (4) ou non amovible (5). Serrez l'écrou de pivot à la main. Fixez la tige horizontale au feuillard (6) à l'aide de l'agrafe (7).

- B.** Appliquez du composé d'étanchéité à la silicone sous la collerette (1). Visser le corps (2) sur la bride et serrer à la main. Alors que le pivot (3) fait face au robinet, tirez le renvoi directement vers le bas dans l'orifice de l'évier, puis fixez le joint (4) et l'écrou (5). **NE TOURNEZ PAS LE RENVOI PENDANT QUE VOUS SERREZ L'ÉCROU EN LAITON CAR LE COMPOSÉ À LA SILICONE POURRA NE PAS ASSURER L'ÉTANCHÉITÉ DU RENVOI.** Enlevez l'excès de composé d'étanchéité.
- D.** Introduisez la tirette (1) dans le robinet et le feuillard (2). Serrez la vis (3). Raccordez l'ensemble au renvoi (4).

RACCORDEMENT À LA TUYAUTERIE D'ALIMENTATION (RACCORDS NON FOURNIS)

Vous pouvez utiliser l'un ou l'autre des modes de branchement suivants: Tubes-raccords à extrémité arrondie (tube de cuivre 3/8 po d.e.) (1) avec écrous de raccordement (3) (non fournis) ou, raccords 1/2 po IPS pour robinetterie (2).

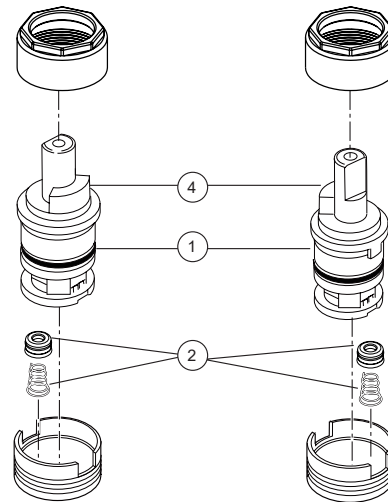
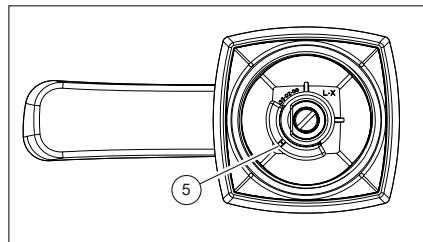
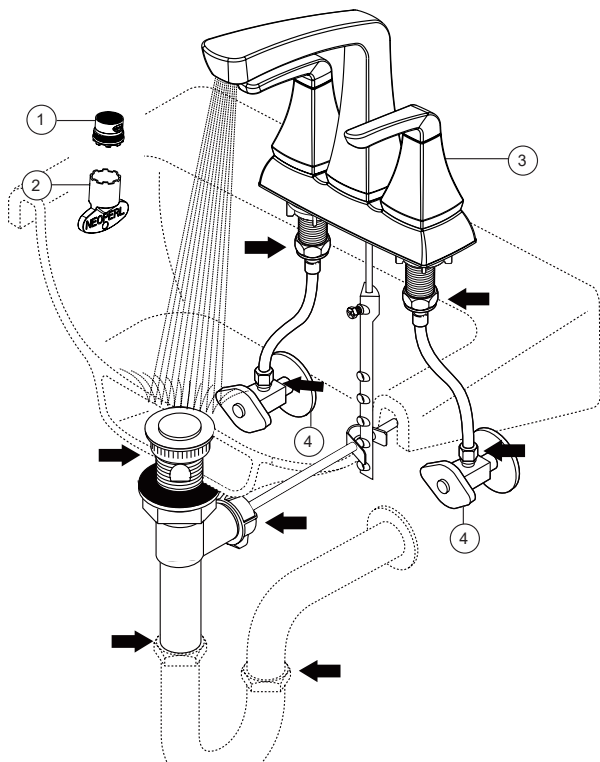

FLUSH SYSTEM/CHECK FOR LEAKS.

Remove aerator (1) using supplied wrench (2) and turn faucet handles (3) to the full on mixed position. Turn on hot and cold water supplies (4) and flush water lines for one minute.

Important: This flushes away any debris that could cause damage to internal parts.

Check all connections at arrows for leaks. Replace aerator. Re-tighten if necessary, but do not over-tighten.

Maintenance

SHUT OFF WATER SUPPLIES

NOTE: Remove handles by hand turning handle base counterclockwise.

If faucet leaks from spout outlet:

Replace Stem Unit Assembly (1) and Seats and Springs (2)*.

If faucet exhibits very low flow:

A. Remove and clean Aerator (3) (page 5), or
B. Clean Seats and Springs (2) of any debris.

*Install stems (1) correctly for proper handle rotation:

Note:

1. The stops (4) must point to the center of the faucet for proper handle rotation.
2. Replace handle properly. Be sure the handle with "H" mark (5) to be installed onto the left and the handle with "C" mark onto the right.

DEJE CORRER EL AGUA POR EL SISTEMA/EXAMINE POR SI HAY FILTRACIONES.

Quite el aereador (1) usando la llave de tuercas (2) proporcionada con su llave de agua y gire las manijas de la llave de agua (3) a la posición completamente abierta. Abra los suministros de agua caliente y fría (4) y deje que el agua corra por las líneas por un minuto.

Importante: Esto limpia cualquier escombros que pudiera causar daño a las partes internas.

Examine para asegurarse que no haya filtraciones. Reemplace el aireador. Apriete de nuevo si es necesario, pero no apriete demasiado.

Mantenimiento

CIERRE LOS SUMINISTROS DE AGUA

NOTA: Saque la manilla girando la base de manilla en contra del sentido de las agujas de reloj.

Si la llave tiene fugas en la salida:

Reemplace los Ensamble de la Unidad del Vástago (1) y Asientos y Resortes (2)*, Equipo para Reparación RP78871.

Si la llave muestra un flujo muy bajo:

A. Quite y limpie el aireador (3) (página 5), o
B. Limpie los Asientos y Resortes (2) de cualquier escombros.

*Instale las espigas (1) correctamente para una giración correcta de la manija:

Note:

1. Los toques (4) deben señalar al centro de la llave de agua para obtener una rotación apropiada de la manija.
2. Vuelva a colocar manilla adecuadamente. Be sure the handle with "H" mark (5) to be installed onto the left and the handle with "C" mark onto the right.

RINÇAGE DE L'INSTALLATION ET VÉRIFICATION DE L'ÉTANCHÉITÉ.

Retirez l'aérateur (1) en utilisant la clé (2) et tournez les poignées (3) du robinet en position d'écoulement maximum de l'eau chaude et de l'eau froide. Rétablissez l'alimentation en eau chaude et en eau froide (4), puis laissez s'écouler l'eau une minute.

Important: Il faut laisser s'écouler l'eau pour évacuer les saletés qui pourraient abîmer les éléments internes du robinet.

Vérifiez l'étanchéité. Remettez l'aérateur en place. Serrez-les de nouveau au besoin, mais prenez garde de trop serrer.

Entretien

INTERROMPEZ L'ARRIVÉE D'EAU

NOTE: Enlevez des poignées par la main en tournant la poignée par en base en sens inverse des aiguilles d'une montre.

Si le robinet fuit par le bec :

Remplacez l'obturateur (1) ainsi que les sièges et les ressorts (2)*.

Si le débit du robinet est très faible:

A. Enlevez l'aérateur (3) (page 5) et nettoyez-le.
B. Vous pouvez aussi nettoyer les sièges et les ressorts (2).

*Installez les obturateurs (1) correctement pour que les manettes pivotent dans le bon sens.

Note:

1. les butées (4) doivent pointer vers le centre du robinet pour que les manettes pivotent correctement.
2. Remplacez la poignée correctement. Lamanette portant la lettre " H " (3) doit être montée du côté gauche et lamanette portant la lettre " C ", du côté droit.

Cleaning and Care

Care should be given to the cleaning of this product. Although its finish is extremely durable, it can be damaged by harsh abrasives or polish. To clean, simply wipe gently with a damp cloth and blot dry with a soft towel.

Limpieza y Cuidado de su Llave

Tenga cuidado al limpiar este producto. Aunque su acabado es sumamente durable, puede ser afectado por agentes de limpieza o para pulir abrasivos. Para limpiar su llave, simplemente frótela con un trapo húmedo y luego séquela con una toalla suave.

Instructions de nettoyage

Care should be given to the cleaning of this product. Although its finish is extremely durable, it can be damaged by harsh abrasives or polish. To clean, simply wipe gently with a damp cloth and blot dry with a soft towel.

Limited Warranty on Delta® Faucets

Parts and Finish: All parts (other than electronic parts and batteries) and finishes of Delta® faucets purchased from authorized Delta sellers are warranted to the original consumer purchaser to be free from defects in material and workmanship for as long as the original consumer purchaser owns the home in which the faucet was first installed. For commercial purchasers, (a) the warranty period is ten (10) years for multi-family residential applications and (b) five (5) years for all other commercial applications, in each case from the date that the product is received by the original purchaser or their authorized representative (installation contractor, etc.). For purposes of this warranty, the term "multi-family residential application" refers to the purchase of the faucet from an authorized Delta seller by a purchaser who owns but does not live in the residential dwelling in which the faucet is initially installed, such as in a rented or leased single unit or multi-unit detached home (duplex or townhome), or a condominium, apartment building or community living center. The following installations are not considered multi-family residential applications, are excluded from the 10-year warranty and are subject to the 5-year warranty: industrial, institutional or other business premises, such as a dormitory, hospitality premises (hotel, motel or extended stay location), airport, educational facility, long- or short-term healthcare facility (hospital, rehabilitation center, nursing, assisted or staged-care living unit), public space or common area.

Parts and Finish for Delta® Recertified Faucets: Delta Faucet Company offers for sale online Delta® Recertified faucets. Delta® Recertified faucets only include faucets that have been certified as such by Delta Faucet Company. All parts (other than electronic parts and batteries) and finishes of these Delta® Recertified faucets are warranted to the original consumer purchaser to be free from defects in material and workmanship for ten (10) years from the date that the product is received by the original purchaser or their authorized representative (installation contractor, etc.). For commercial purchasers, the warranty period is one (1) year from the date that the product is received by the original purchaser or their authorized representative (installation contractor, etc.).

Electronic Parts: Electronic parts (other than batteries), if any, of Delta® faucets purchased from deltafaucet.com or authorized Delta sellers are warranted to the original consumer purchaser to be free from defects in material and workmanship for five (5) years from the date that the product is received by the original purchaser or their authorized representative (installation contractor, etc.) or, for commercial purchasers, for one (1) year from the date that the product is received by the original purchaser or their authorized representative (installation contractor, etc.). No warranty is provided on batteries.

What We Will Do: Delta Faucet Company will repair or replace, free of charge, during the applicable warranty period (as described above), any part or finish that proves defective in material and/or workmanship under normal installation, use and service. Delta Faucet Company may, in its sole discretion, use new, refurbished or recertified parts or products for such repair or replacement. If repair or replacement is not practical, Delta Faucet Company may elect to refund the purchase price in exchange for the return of the product. **These are your exclusive remedies.**

What is Not Covered: Because Delta Faucet Company is unable to control the quality of Delta products sold by unauthorized sellers, unless otherwise prohibited by law, this warranty does not cover Delta products purchased from unauthorized sellers.

Any labor charges incurred by the purchaser to repair, replace, install or remove this product are not covered by this warranty. Delta Faucet Company shall not be liable for any damage to the faucet resulting from reasonable wear and tear, outdoor use, misuse (including use of the product for an unintended application), freezing water, abuse, neglect or improper or incorrectly performed installation, maintenance or repair, including failure to follow the applicable care and cleaning instructions. Delta Faucet Company recommends using a professional plumber for all installation and repair of faucets. We also recommend that you use only genuine Delta® replacement parts.

What You Must Do To Obtain Warranty Service or Replacement Parts: A warranty claim may be made and replacement parts may be obtained by calling 1 800 345 DELTA (3358) or by contacting us by mail or online as follows (please include your model number, date of original purchase and documentation of the date of receipt of the product by the original purchaser or their authorized representative (installation contractor, etc.)):

In the United States and Mexico:
Delta Faucet Company
55 E. 111th Street
Carmel, IN 46280
Attention: Warranty Service
www.deltafaucet.com/service-parts/contact-us

In Canada:
Masco Canada Limited, Plumbing Group
Technical Service Centre
350 South Edgeware Road
St. Thomas, Ontario, Canada N5P 4L1
Attention: Customer Service
<http://www.deltafaucet.ca/customersupport/assistance.html>

Proof of purchase (original sales receipt showing purchase date) and documentation of the date of receipt of the product by the original purchaser or their authorized representative (installation contractor, etc.) from the original purchaser must be made available to Delta Faucet Company for all warranty claims unless the purchaser has registered the product with Delta Faucet Company or the product is a Delta® Recertified product purchased from deltafaucet.com. This warranty applies only to Delta® faucets manufactured after January 1, 2019 and installed in the United States of America, Canada and Mexico.

Limitation on Duration of Implied Warranties: Please note that some states/provinces (including Quebec) do not allow limitations on how long an implied warranty lasts, so the below limitations may not apply to you. TO THE MAXIMUM EXTENT PERMITTED BY APPLICABLE LAW, ANY IMPLIED WARRANTY, INCLUDING THE IMPLIED WARRANTIES OF MERCHANTABILITY AND OF FITNESS FOR A PARTICULAR PURPOSE, IS LIMITED TO THE STATUTORY PERIOD OR THE DURATION OF THIS WARRANTY, WHICHEVER IS SHORTER.

Limitation of Special, Incidental or Consequential Damages: Please note that some states/provinces (including Quebec) do not allow the exclusion or limitation of special, incidental or consequential damages, so the below limitations and exclusions may not apply to you. TO THE MAXIMUM EXTENT PERMITTED BY APPLICABLE LAW, THIS WARRANTY DOES NOT COVER, AND DELTA FAUCET COMPANY SHALL NOT BE LIABLE FOR, ANY SPECIAL, INCIDENTAL OR CONSEQUENTIAL DAMAGES (INCLUDING LABOR CHARGES TO REPAIR, REPLACE, INSTALL OR REMOVE THIS PRODUCT), WHETHER ARISING OUT OF BREACH OF ANY EXPRESS OR IMPLIED WARRANTY, BREACH OF CONTRACT, TORT, OR OTHERWISE. DELTA FAUCET COMPANY SHALL NOT BE LIABLE FOR ANY DAMAGE TO THE FAUCET RESULTING FROM REASONABLE WEAR AND TEAR, OUTDOOR USE, MISUSE (INCLUDING USE OF THE PRODUCT FOR AN UNINTENDED APPLICATION), FREEZING WATER, ABUSE, NEGLIGENCE OR IMPROPER OR INCORRECTLY PERFORMED INSTALLATION, MAINTENANCE OR REPAIR, INCLUDING FAILURE TO FOLLOW THE APPLICABLE INSTALLATION, CARE AND CLEANING INSTRUCTIONS. Notice to residents of the State of New Jersey: The provisions of this warranty, including its limitations, are intended to apply to the fullest extent permitted by the laws of the State of New Jersey.

Additional Rights: This warranty gives you specific legal rights, and you may also have other rights which vary from state/province to state/province. This is Delta Faucet Company's exclusive written warranty and the warranty is not transferable.

If you have any questions or concerns regarding our warranty, please contact us as provided above or view our Warranty FAQs at www.deltafaucet.com.

© 2023 Masco Corporation of Indiana