

Cleaning / Limpieza / 清洗 / 클리닝 / Limpeza

Cleaning

Care should be given to the cleaning of this product. Although the finish is extremely durable, it can be damaged by harsh abrasives or polish. To clean simply wipe gently with a damp cloth, and wipe dry with a soft towel.

Limpieza

Debe de tener cuidado en la limpieza de este producto. Aunque su acabado es extremadamente durable, puede ser dañado con abrasivos o pulimentos ásperos. Para limpiar simplemente frote suavemente con un paño húmedo, y séquelo con un paño suave.

清洗

清洗本产品时需加小心, 尽管本产品的表面镀层极其耐用, 但仍有可能被尖利摩擦物或打光物所损伤。清洗时只需用湿布轻轻擦拭, 然后用软毛巾拭干即可。

점소방법

본 제품을 청소할 때는 특별한 주의를 기울여야 합니다. 비록 매우 내구성있게 마무리된 제품이지만 하지만 기린 인마제나 공택재료를 사용할 경우, 손상의 우려가 있습니다. 청소할 때는 물에 적신 천으로 부드럽게 닦아 주고, 또한 부드러운 수건으로 물기를 닦아주기만 하면 됩니다.

Limpeza

Cuidado ao limpar o produto. Use apenas um pano limpo umido. E para secar use um pano macio.

Note / Nota / 注意 / 참고 / Observação

1. Working pressure: 0.05Mpa-0.7Mpa

Recommended working pressure: 0.2Mpa-0.5Mpa

2. Delta reserves the right (1) to make changes in specifications and materials, and (2) to change or discontinue models, both without notice or obligation.

1. Presión de trabajo: 0.05Mpa-0.7Mpa

Presión de trabajo recomendada: 0.2Mpa-0.5Mpa

2. Delta reserva los derechos(1) de hacer modificaciones sobre las especificaciones y materiales y (2) de modificar los modelos, sin obligación de notificar por separado.

1. 工作压力: 0.05Mpa-0.7Mpa

最佳工作压力为: 0.2Mpa-0.5Mpa

2. 本公司保留对德雅产品进行修改, 改进的权利, 技术参数如有改变, 恕不另行通知。

1. 작동압력 0.05Mpa-0.7Mpa

최적 작동압력은: 0.2Mpa-0.5Mpa

2. 더얼다회사는 제품에 대한 수선, 개량의 권리를 보유하고 있으며 기술참수에 대한 변경을 별도로 통보하지 않는다.

1. Pressão de Trabalho: 5 m.c.a (0.05Mpa) - 70 m.c.a (0.7Mpa).

Melhor Pressão de Trabalho: 20 m.c.a (0.2Mpa) - 50 m.c.a (0.5Mpa).

2. Delta reserva o direito (1) de fazer alterações e melhorias do produto, e não avisa especificamente, em caso de alterações de parâmetros técnicos.

 Delta Faucet Company
A division of Masco Corporation of Indiana
55 East 111th Street, Indianapolis, Indiana 46280
United States of America



Helpline:
(877) 509-2680 (International)
400-880-0360 (China)



Website:
worldwide.deltafaucet.com (International)
www.deltafaucet.com.cn (China)



Model / Modelo / 型号 / 모델 / Modelo

S360 / DCS360

S350-CH / DCS350-CH

S450-CH / DCS450-CH

S650-CH / DCS650-CH

S660 / DCS660

S661 / DCS661

S662 / DCS662

S663 / DCS663

S664 / DCS664

S665 / DCS665

S860 / DCS860

S860-CH / DCS860

S750-CH / DCS750-CH

S850-CH / DCS850-CH

S880 / DCS880

Series / Series / 系列 / 시리즈 / Série

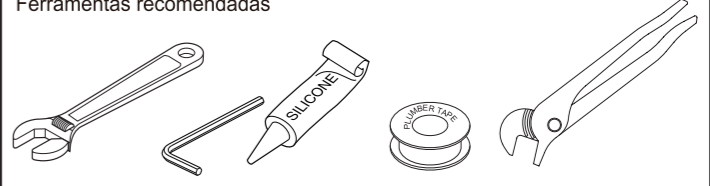
<p>Dear Customer,</p> <p>Thank you for selecting Delta product, a product that will give you years of dependable service! Each faucet is built using only the very best materials and the latest manufacturing technology. Engineered for durability, we are confident you will enjoy your new faucet for years to come.</p> <p>* Pictures are only for installation instruction. Please subject to the confirmed sample.</p>	<p>Estimado cliente,</p> <p>Gracias por seleccionar Delta Faucet ¡un producto que le dará años de servicio confiable! Cada llave está fabricada usando solamente los mejores materiales y la última tecnología en fabricación. Construida para durabilidad, estamos seguros de que su nueva llave la disfrutará por años.</p> <p>* El dibujo solo sirve de instrucción de montaje. Refiérase al producto.</p>
<p>尊敬的顾客:</p> <p>非常感谢您选择德雅产品, 本产品选用高质量材料, 采用最新的生产技术, 具有极好的耐久性, 将为您提供多年可靠的服务。</p> <p>* 图示仅限于安装指引, 请以实物为准。</p>	<p>고객 서위계,</p> <p>먼저 델타 수도꼭지를 선택해 주신 것에 대해서 감사의 말씀을 드립니다. 저희 제품은 오랜 동안 고장의 우려없이 사용할 수 있는 믿을 수 있는 제품입니다. 가장 좋은 재료를 사용했을 뿐만 아니라 가장 현대적 제조기술을 이용하여 제조되었기 때문입니다. 이러한 공학적 제조과정을 통한 내구성의 실현으로 귀하께 사용의 즐거움을 드리리라 확신하는 바입니다.</p> <p>* 안내도는 설치작업 참고용입니다. 실물을 기준으로 하시기 바랍니다.</p>
<p>Prezado Consumidor:</p> <p>Obrigado por escolher Delta Faucet. Nossos produtos possuem materiais de alta qualidade, com excelente durabilidade, pois são fabricados com alta tecnologia de produção, que permitirá ser utilizados por muitos anos.</p> <p>* As ilustrações são apenas referências para as instruções de instalação.</p>	<p>Recommended tools / Herramientas recomendadas / 建议工具 / 권장도구 / Ferramentas recomendadas</p> 

Installation dimensions / Dimensiones de la instalación / 安装尺寸 / 설치 치수 / Dimensões de instalação

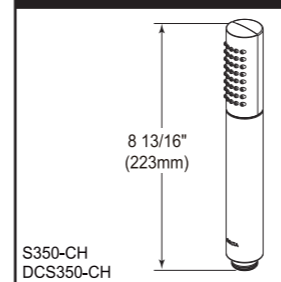
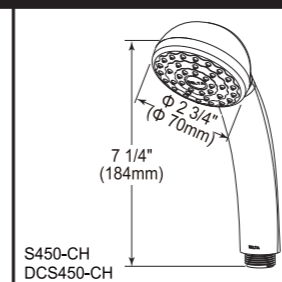
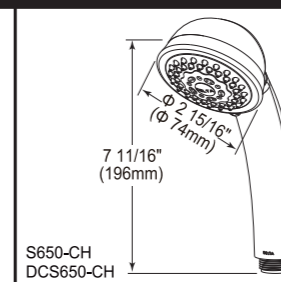
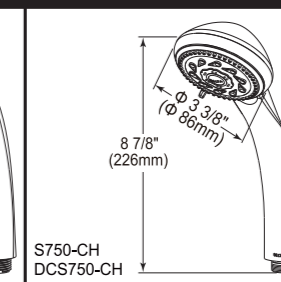
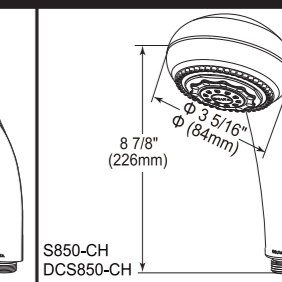
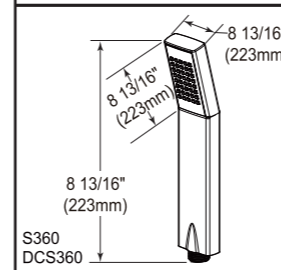
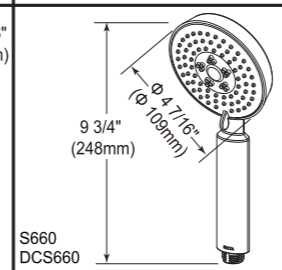
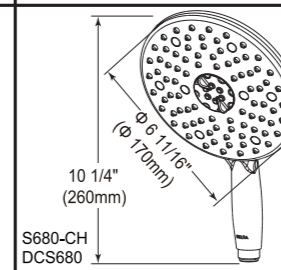
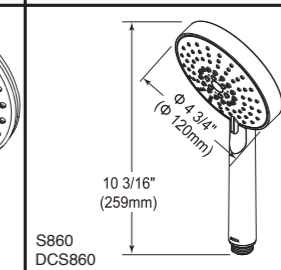
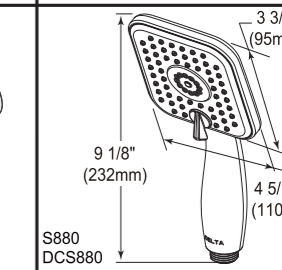
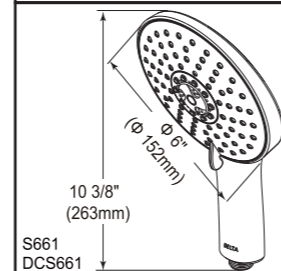
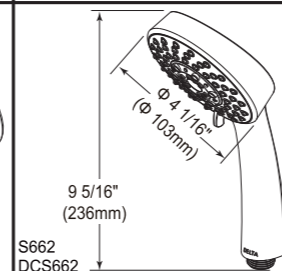
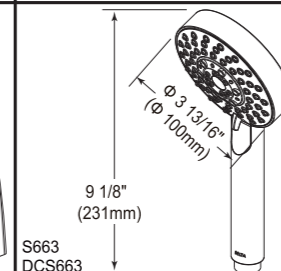
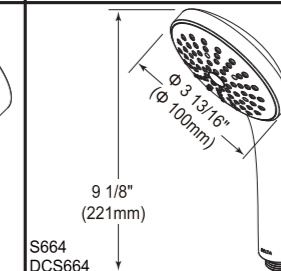
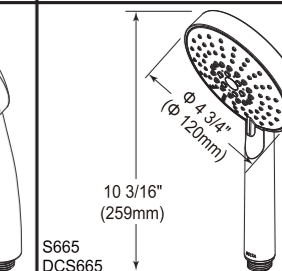
 <p>S350-CH DCS350-CH</p>	 <p>S450-CH DCS450-CH</p>	 <p>S650-CH DCS650-CH</p>	 <p>S750-CH DCS750-CH</p>	 <p>S850-CH DCS850-CH</p>
 <p>S360 DCS360</p>	 <p>S660 DCS660</p>	 <p>S680-CH DCS680</p>	 <p>S860 DCS860</p>	 <p>S880 DCS880</p>
 <p>S661 DCS661</p>	 <p>S662 DCS662</p>	 <p>S663 DCS663</p>	 <p>S664 DCS664</p>	 <p>S665 DCS665</p>

Installation and Connections / Instalación y conexiones / 安装和连接 / 설치 및 연결을 / Instalação

1. Drill holes and install holder, hole size 1/4" (6mm), figure 1.
 Perfore como la figura 1 e instale la base de pared, el diámetro de la perforación es 1/4" (6mm).
 按照图1钻孔和安装底座, 钻孔尺寸1/4" (6mm)。
 도면1에 따라 천공하고 벽좌에 설치, 천공 사이즈는 1/4"(6mm).
 Segundo o Diagrama 1, perfure buracos e instale base da parede, com tamanho de buraco de 1/4 "(6mm).

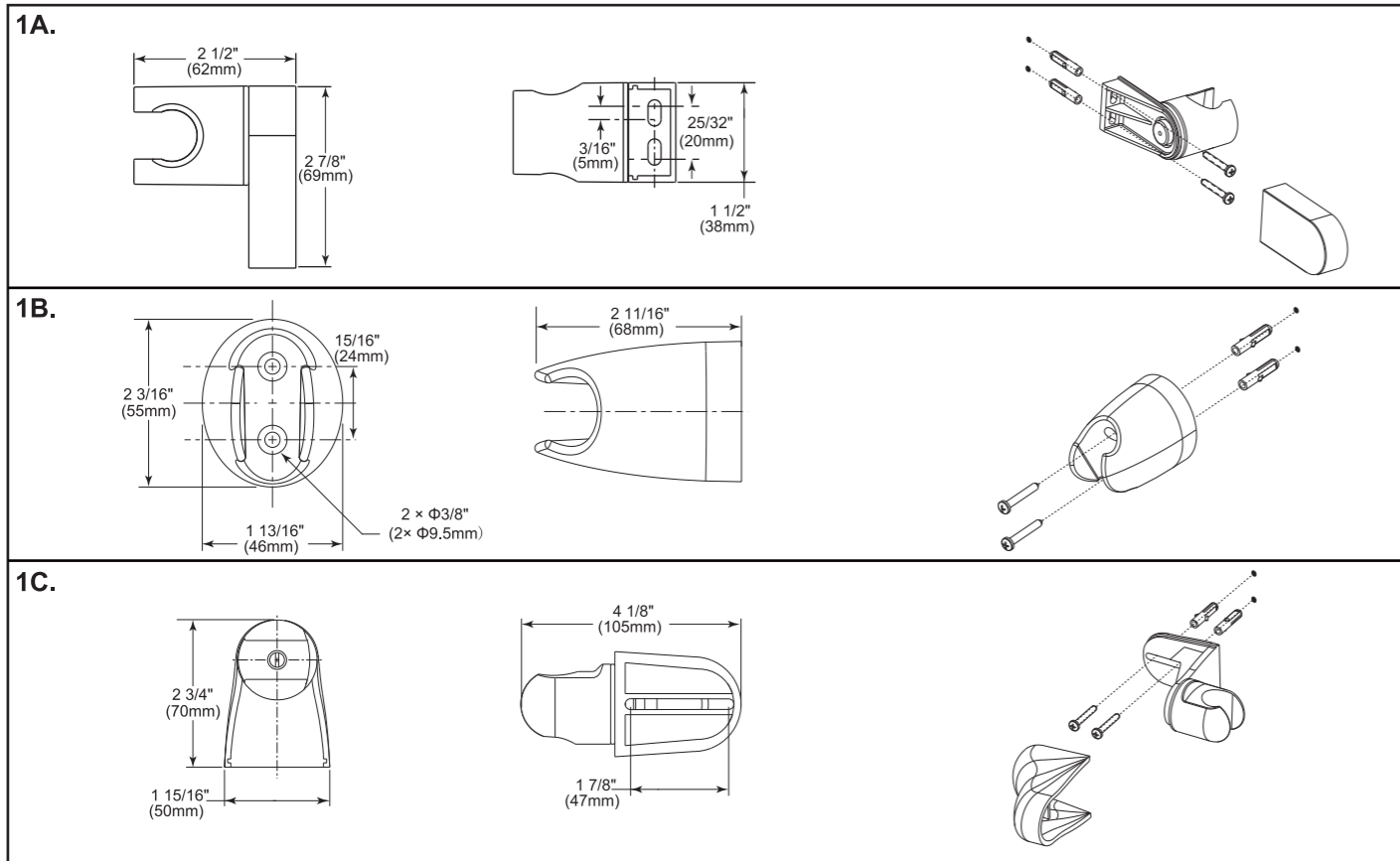

2. Connect the hose to your designated water supply, figure 2A. Connect tapered end of hose to hand shower, figure 2B.
Note: Ensure gasket (1) is inserted into the hose.
 Conecte la manguera al suministro de agua declaradas, la figura 2A. Conecte el extremo estrecho de la manguera de ducha de mano, figura 2B.
Nota: Asegúrese de empaque (1) se inserta en la manguera.
 将软管连接出水口, 图2A, 软管锥形的另一端(1)连接花洒, 图2B。注意: 连接时确定密封圈(2)已在软管内。
 지정된 물 공급, 그림 2A에 호스를 연결합니다. 손 샤워, 그림 2B에 호스 테이퍼 끝을 연결합니다. 참고: 가스켓(2) 확인은 호스에 삽입
 Conecte a mangueira de abastecimento de água para o seu designado, 2A figura. Ligue extremidade cônica da mangueira para chuveiro de mão, figura 2B.
Nota: Certifique junta (1) é inserida na mangueira.

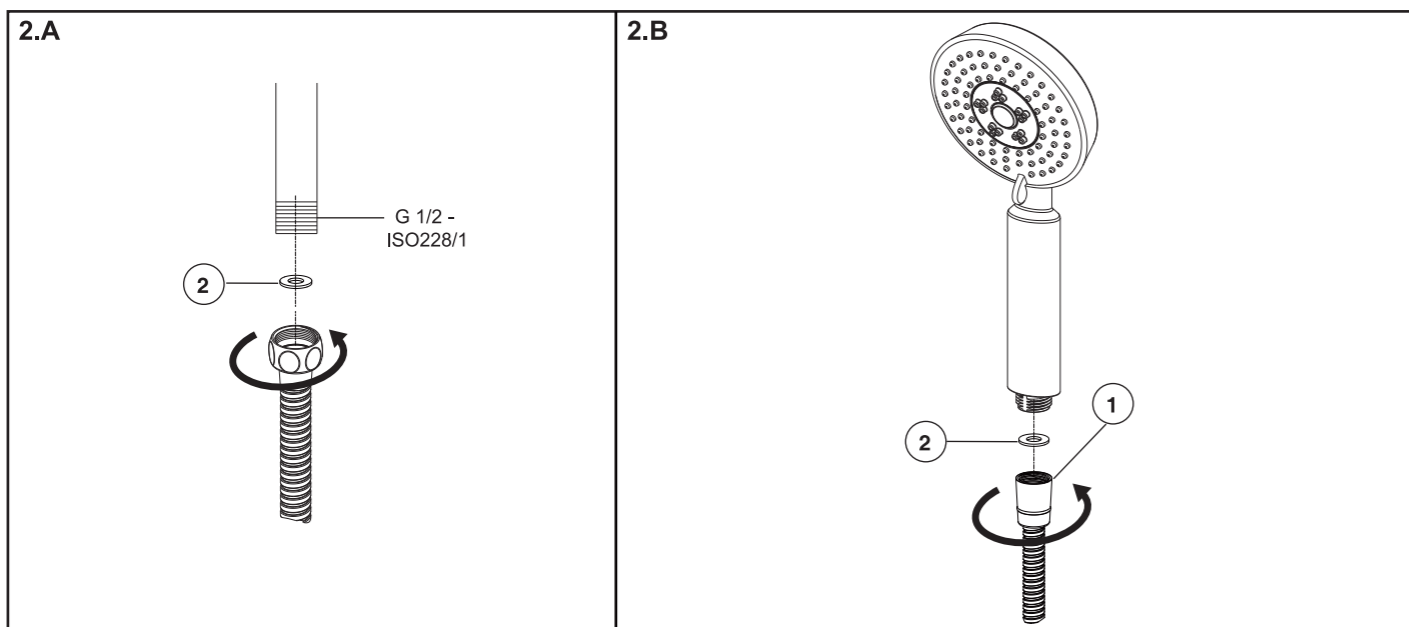

Parts / Piezas / 零件图 / 부품 / Partes

Single setting 1 función 単機能 단일기능 1 função	S350-CH DCS350-CH RP72951	S360 DCS360 RP44966	S450-CH DCS450-CH RP37529	S664 DCS664 RP76455	
3 setting 3 funciones 三功能 3종기능 3 função	S650-CH DCS650-CH RP37530	S660 DCS660 RP73436	S680-CH DCS680 RP74719	S880 DCS880 RP71099	
5 setting 5 funciones 五功能 5종기능 5 função	S850-CH DCS850-CH RP37531	S750-CH DCS750-CH RP44380	S662 DCS662 RP76453	S663 DCS663 RP76454	S665 / DCS665 S860 / DCS860 RP76456
7 setting 7 funciones 七功能 7종기능 7 função	S661 DCS661 RP76452				
Holder Asidero 牆座 받치는 것 Titular	RP44967	RP38995	RP33524		
Hose Manguera 软管 샤워연관 Mangueira	RP44968 Anti-twist, flexile hose Manguera anti-enrollado de ducha 防缠绕花洒软管 샤워연관 휘감김을 방지 Mangueira de chuveiro anti-enrolamento	RP49519 Tensile flexile hose Manguera extensible de ducha 可拉伸花洒软管 샤워연관 인장가능 Mangueira de chuveiro que pode extender-se	RP37528 Flexile hose Manguera de ducha 花洒软管 샤워연관 Mangueira de chuveiro		