

EDGE TREATMENT & GROOVING BITS



Convex Edge Bit

USE IN



Table Router

Hand Router

CNC

APPLICATION

Shallow bull nose profile for edging. creates a soft, gently rounded edge on any project or use this bit to plunge rout internal cut-outs for use as hand-holds.

MATERIALS



Hardwood

Softwood

MDF

Plywood

ITEM NUMBER	OVERALL DIA.	CARBIDE HEIGHT	MINOR HEIGHT	LARGE RADIUS	SHANK DIA.	OVERALL LENGTH
99-019	1"	1-5/8"	7/8"	39/64"	1/2"	3-1/16"

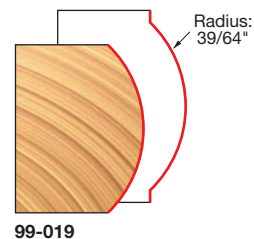
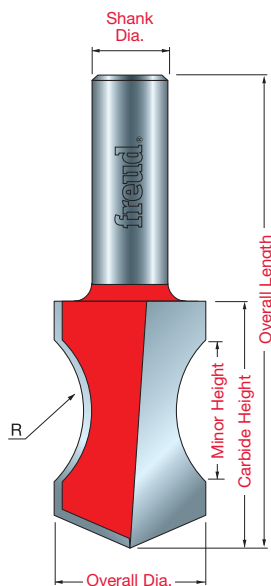

99-019

Example of interior cut-out for use as a hand-hold.

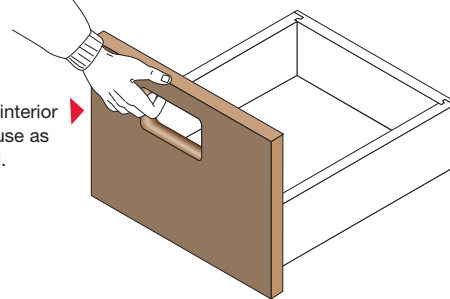

EDGE TREATMENT & GROOVING BITS



Rounding Over Bits

USE IN



Table Router

Hand Router

CNC

APPLICATION

Soften furniture edges and create decorative beads. For beading work, equip the bits with a 1/8" smaller bearing and step washer.

MATERIALS



Hardwood

Softwood

MDF

Plywood



ITEM NUMBER	OVERALL DIA.	BEARING DIA.	CARBIDE HEIGHT	LARGE RADIUS	SHANK DIA.	OVERALL LENGTH
34-100	5/8"	1/2"	1/2"	1/16"	1/4"	2-3/16"
34-104	3/4"	1/2"	1/2"	1/8"	1/4"	2-3/16"
34-106	13/16"	1/2"	1/2"	5/32"	1/4"	2-3/16"
34-108	7/8"	1/2"	1/2"	3/16"	1/4"	2-3/16"
34-110	1-1/8"	5/8"	1/2"	1/4"	1/4"	2-3/16"
34-112	1-1/4"	5/8"	1/2"	5/16"	1/4"	2-3/16"
34-114	1-3/8"	5/8"	5/8"	3/8"	1/4"	2-3/16"
34-116	1-1/2"	1/2"	3/4"	1/2"	1/4"	2-1/2"
34-117	5/8"	1/2"	1/2"	1/16"	1/2"	2-1/2"
34-118	3/4"	1/2"	1/2"	1/8"	1/2"	2-1/2"
34-119	7/8"	1/2"	1/2"	3/16"	1/2"	2-1/2"
34-120	1-1/4"	3/4"	1/2"	1/4"	1/2"	2-1/2"
34-122	1-1/8"	3/4"	1/2"	5/16"	1/2"	2-1/2"
34-124	1-1/2"	3/4"	5/8"	3/8"	1/2"	2-5/8"
34-126	1-5/8"	5/8"	3/4"	1/2"	1/2"	2-3/4"
34-127	1-7/8"	5/8"	7/8"	5/8"	1/2"	2-7/8"
34-128	2"	1/2"	1"	3/4"	1/2"	2-7/8"
34-130	2-1/4"	1/2"	1-1/4"	7/8"	1/2"	3-1/8"
34-132	2-1/2"	1/2"	1-1/4"	1"	1/2"	3-1/8"
34-134	2-3/4"	1/2"	1-3/8"	1-1/8"	1/2"	3-1/4"
34-136	3"	1/2"	1-1/2"	1-1/4"	1/2"	3-3/8"
34-138	3-1/4"	1/2"	1-9/16"	1-3/8"	1/2"	3-3/8"
34-140	3-1/2"	1/2"	1-3/4"	1-1/2"	1/2"	3-5/8"

Rounding Over Bits

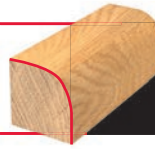

EDGE TREATMENT & GROOVING BITS

CONTINUED

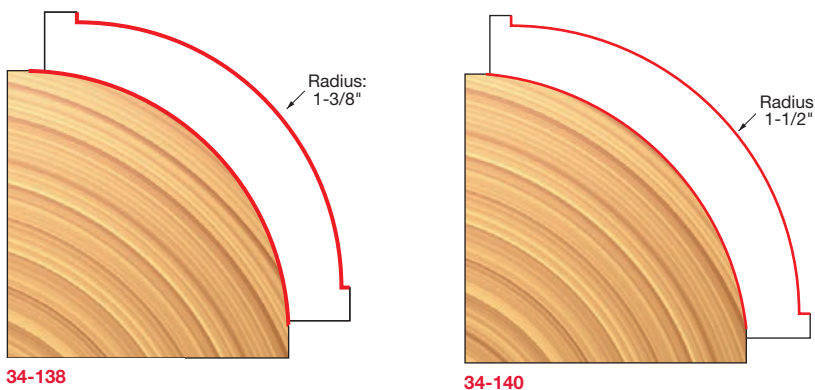
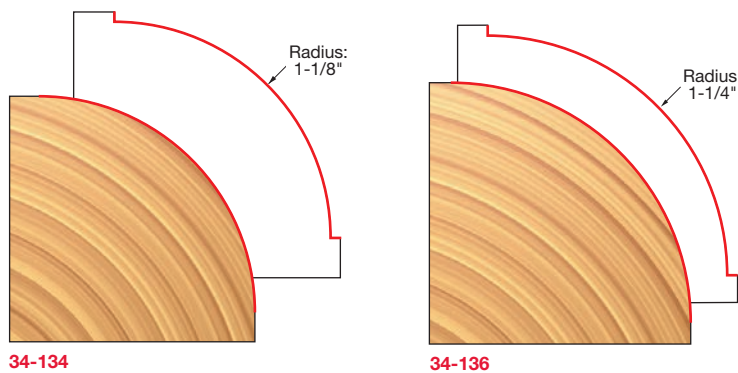
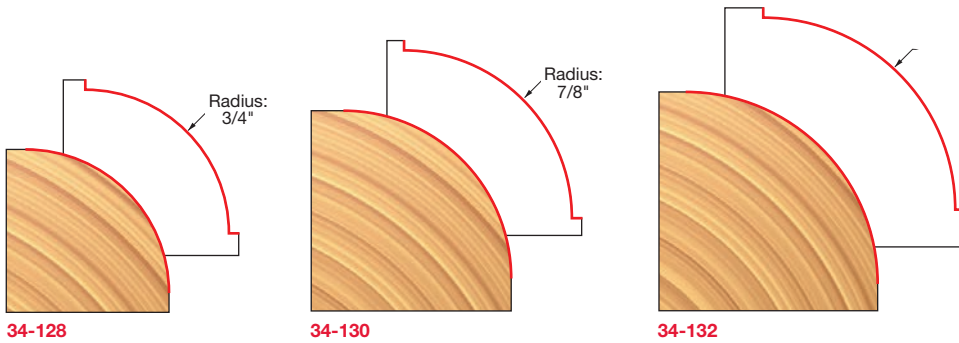
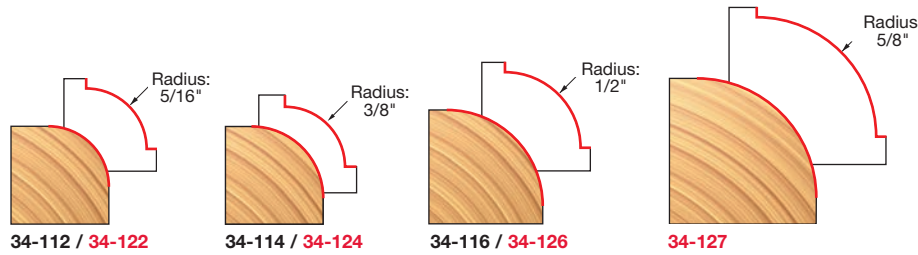
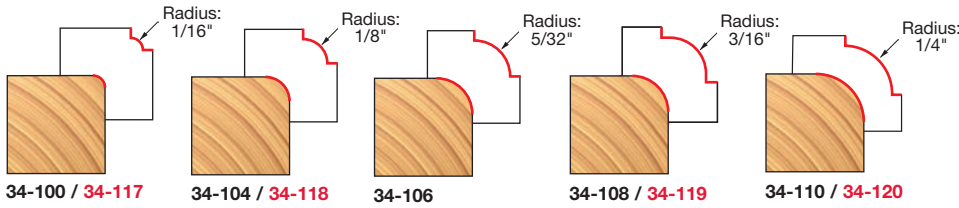

USE IN



Table Router



Hand Router



CNC

APPLICATION

Soften furniture edges and create decorative beads. For beading work, equip the bits with a 1/8" smaller bearing and step washer.

MATERIALS

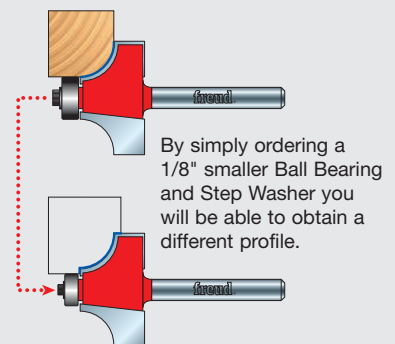
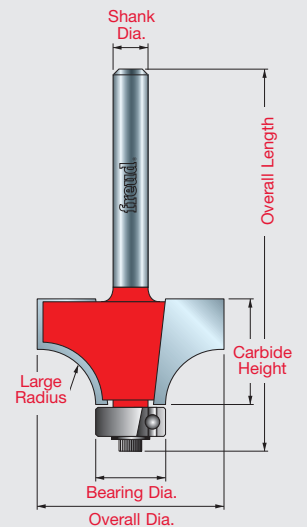

ROUTER BITS

* Solid Carbide

Red Item Numbers Indicate 1/2" Shank

All Profile Drawings 1:1 Scale