



2SHE Wall ventilators

Axial Wall Shutter Fans with Direct Drive Motors

- Heavy-duty guards have a coating to resist corrosion
- All ventilators are UL 705 listed
- OSHA compliant guards
- Enclosed motors
- Shipped ready to install

UL 705 Compliance

Meets the UL 705 Standard to ensure it adheres to rigorous safety and performance requirements and has undergone testing and evaluation.

Highly Durable

The heavy-duty guards feature a gray polyester coating designed to resist corrosion. This makes them suitable for use in a range of environments.

OSHA-compliant

Comes with an OSHA (Occupational Safety & Health Administration) compliant guard to ensure compliance with safety regulations.

Speed Regulation

All models in the SHE Series are speed-controllable (except 2SHE 30C1 and 2SHE 36D1).

Certifications



AMCA Worldwide Certified Ratings: Sound and Air Performance

Systemair certifies that the model shown herein is licensed to bear the AMCA Seal. The ratings shown are based on tests and procedures performed in accordance with AMCA Publication 211 and AMCA Publication 311 and comply with the requirements of the AMCA Certified Ratings Program. Check the AMCA Certified and Listed Product Search for our products <https://www.amca.org/certify/#certified-product-search>



UL Listed

This product is Listed by UL. UL has rigorously tested and confirmed that this product meets all of their stringent requirements. Search the UL Product iQ directory for more information about listed products at <https://productiq.ulprospector.com/>

Technical parameters

Nominal data

Voltage (nominal)	115	V
Frequency	60	Hz
Phases	1~	
Input power	471	W
Input current	4.4	A
Impeller speed	850	rpm
Air flow	max 6,081	cfm
Temperature of transported air	max 104	°F

Protection/Classification

Insulation class	B
------------------	---

Dimensions and weights

Weight	62	lb
--------	----	----

Optional

Motor type	AC
------------	----

Performance

Performance curve

in. wg.

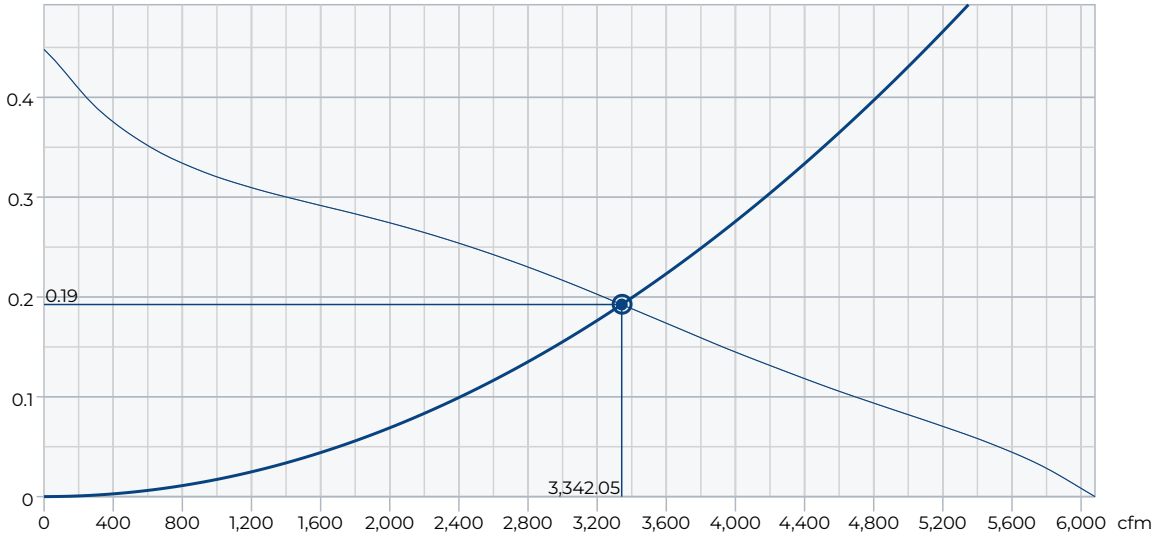

Performance data

Required air flow	3,344 cfm
Required static pressure	0.19 in. wg.
Working air flow	3,342 cfm
Working static pressure	0.19 in. wg.
Air density	0.075 lb/ft ³
Power	428 W
Fan control - RPM	850 rpm
Airflow efficiency	7.8 cfm/W

Sound power level

		63	125	250	500	1k	2k	4k	8k	Total
Inlet	dB(A)	50	56	61	69	71	70	68	63	76

Dimensions

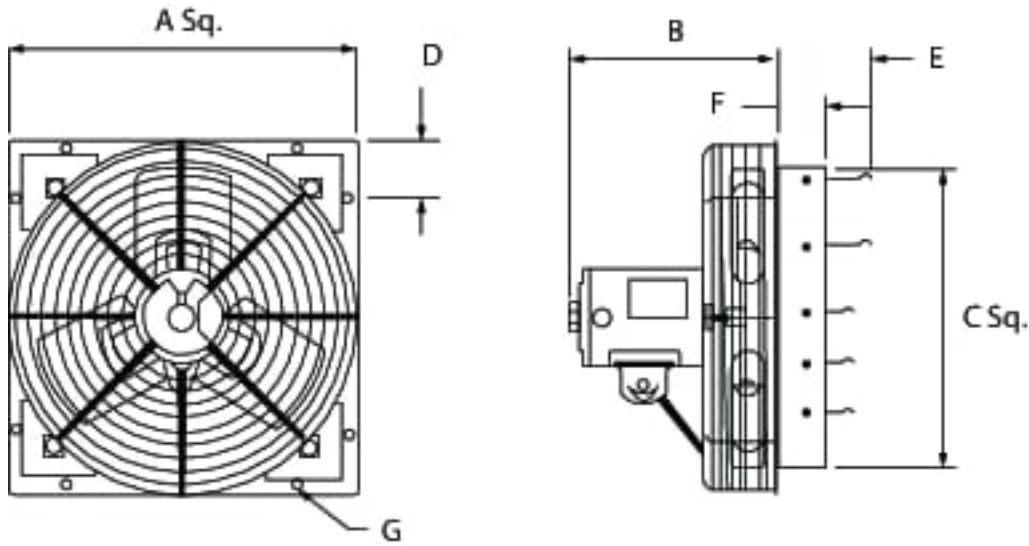

Model	A	B	C	D	E	F	G
2SHE 0721	11	5 3/8	8 1/8	3 1/2	3 1/2	2 1/4	1/4 X 1/2
2SHE 1021	13	6	10 1/8	3 1/2	3 1/2	2 1/4	1/4 X 1/2
2SHE 1221	15	6 1/8	12 1/4	3 1/2	3 1/2	2 1/4	1/4 X 1/2
2SHE 1621	19	8 3/8	16 1/8	3 1/2	3 1/2	2 1/4	1/4 X 1/2
2SHE 1871	21	9	18 1/8	3 1/2	3 1/2	2 1/4	1/4 X 1/2
2SHE 20B1W	23	10 1/4	20 1/8	3 1/2	3 1/2	2 1/4	1/4 X 1/2
2SHE 24B1W	27	9 7/8	24 1/8	3 1/2	3 1/2	2 1/4	1/4 X 1/2
2SHE 30C1	33	13 1/2	30	3 1/2	3	3	1/4 X 1/2
2SHE 36D1	39	13 1/2	36	3 1/2	3	3	1/4 X 1/2

Dimensions in inches

Wiring

CONNECTIONS

COM - WHITE

HIGH - BLACK

WHITE ———→ LINE 1

BLACK ———→ LINE 2

CCW LEAD END ROTATION

AHU Accessories

- FH 20 Dehumidistat (410727)
- 5ACC 01MS Motor disc. switch (47182)
- FTD7 7-day digital timer (49792)
- PT6 Attic Thermostat (494085)

Documents

- 481810 2SHE OIPM EN.PDF
- 2SHE Submittal Sheet EN.pdf
- 47104.dxf