

Honeywell Home

T10 & T10+ PRO SMART THERMOSTAT WITH REDLINK® 3.0

PRODUCT DATA

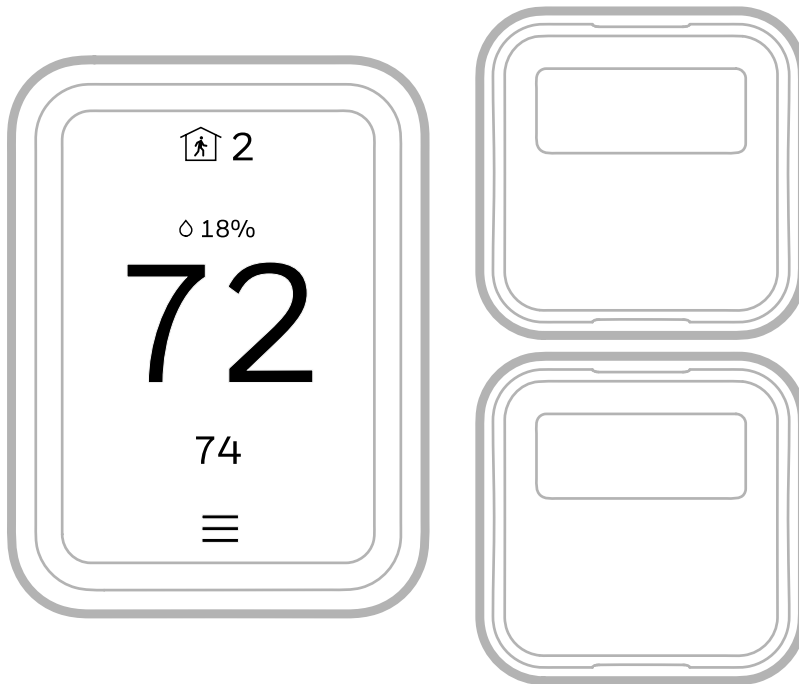

M37811A



33-00462-07

Table of Contents

APPLICATION	5
FEATURES	6
Apple® HomeKit™ Setup Code	6
SPECIFICATIONS	7
Model Numbers	9
Dimensions	10
SYSTEM INSTALLATION	12
When Installing This Product... ..	12
Finding Your Date Code	12
Selecting Thermostat Location	12
UWP Mounting System Installation	12
Optional Decorative Cover Plate Installation	13
Wiring UWP	14
Setting Slider Tabs	19
WIRING DIAGRAMS	20
Wiring at T10 or T10+ without EIM	20
Fan Coil Unit Wiring Diagrams without EIM	27
Whole house humidifier, dehumidifier, or ventilator wiring using the U slider tab	30
INSTALLING EQUIPMENT INTERFACE MODULE (IF USED)	31
EIM Wiring Diagrams	31
Fan Coil Unit Wiring Diagrams with EIM	35
Wiring Dry Contact Alerts with EIM	40
Linking the T10+ to an Optional EIM	41
To Replace the Equipment Interface Module (EIM)	43
To replace a T10+ connected to an EIM	43
SENSOR INSTALLATION	44
Wireless Indoor Sensor Installation	44
Wireless Outdoor Sensor Installation	46
Selecting Return Air Temperature Sensor Mounting Location	47
Selecting Discharge Air Temperature Sensor Mounting Location	47
Installing Discharge and/or Return Air Temperature Sensors (T10+ only)	49
Installing Wired Indoor Sensor	49
Installing Wired Outdoor Sensor	50
Floor/Slab Sensor (T10+ only)	51
INSTALLER SETUP (ISU)	53
New Installation	53
Revising Settings	53
Installer Setup Options (ISU)	53
WiFi SETUP	74
Connect to a Hidden WiFi Network	75
Unsuccessful WiFi Connection	75
SCHEDULING	76
Setting a Schedule On Thermostat	76
Scheduling Through the App	77
Schedule Override on Device	78

MAIN MENU	80
Main Menu Options	80
Management	81
INSTALLER OPTIONS	83
Installer Options Menu	83
GETTING THE MOST FROM THE T10 OR T10+ SMART THERMOSTAT	86
Apple® HomeKit™ Setup	86
Using Your Thermostat	87
Setting the Time/Date	88
Setting the Fan	88
Setting the System Mode	88
Using Priority	89
Selecting Sensors	89
Priority Screen	89
Alerts and Notifications	89
IAQ Reminders	90
Setting Preferences	91
Inactive Night Backlight	92
Fallback Room (T10+ only)	93
INDOOR AIR QUALITY CONTROL	94
Humidification	94
Dehumidification (Residential)	95
Ventilation	98
ADVANCED FEATURES	100
Cleaning the Thermostat Screen	100
Adjusting Security Settings	100
Dealer Information	100
Auto Changeover Operation	101
Em Heat and Auxiliary Heat Operation	101
Adaptive Intelligent Recovery	102
Compressor Protection	102
P + I Control	102
Heat Differential	102
Upstage Timer	103
Holdoff Timer	103
Programmed Recovery	103
Finish with High Heat stage and/or Finish with High Cool stage	104
Heat Pump and Backup Heat Lockout Operation	104
Fan Coil Unit Settings and Operation	104
Remote Setback (Occupancy Setback / Occupancy Sensor)	105
Dry Contact Alerts (ISU 6000- 6220)	109
Battery Replacement	111
Commercial Features	112
Overriding Schedules: Commercial Use	113
Initiating Occupancy Mode: Commercial Use	114
Ramp Rates	114
Custom Names	115

Economizer and Time of Day (TOD) Operation	115
Pre-Occupancy Purge	116
RESIDEO PRO APP	119
FAQ'S	120
WiFi connection questions	120
First Alert or Resideo account and app questions	120
Software and security questions	120
Other questions	121
TROUBLESHOOTING AND SUPPORT	122
Customer Assistance	125
5-year limited warranty	125
REGULATORY	126

APPLICATION

The T10 and T10+ Smart Thermostats feature effortless, 7-Day programming on an easy-to-use touchscreen.

Compatible with 24 VAC systems including:

- Up to 3 Heat/2 Cool heat pump systems (4 heat with T10+ & EIM)
- Up to 2 Heat/2 Cool conventional (3 Heat/4 Cool with T10+ & EIM)
- Dual Fuel systems
- Radiant hot water systems including hot water fan coil
- Humidification, dehumidification, or ventilation (All three with T10+ & EIM)
- 2-pipe or 4-pipe fan coil units with up to 3 speed fan (T10+ only)

FEATURES

- RedLINK 3.0 C7189R3002 or C7189R2002 Indoor Sensors (Up to 20 sensors per thermostat).
- Increase your content and profit per job by including RedLINK 3.0 indoor temperature, humidity, and motion sensors that meet your customers comfort and convenience needs. They can be used in combination for temperature averaging or individually. These devices also sense motion and you can select priority rooms based on where motion is detected or by scheduling.
- Flexible scheduling: You can choose to use location-based temperature control (**Geofence/Auto Away technology**), program a set schedule or use a combination of both to make sure your home is always comfortable.
- Location-based temperature control: Using Geofence/Auto Away technology, the T10 or T10+ Smart Thermostat will automatically use your smartphone's location, which can save energy when you leave and make your home comfortable by the time you return. See "[Scheduling](#)" on page 76 for more information.
- Smart scheduling: Adds a Sleep period to location-based temperature control. See "[Scheduling](#)" on page 76 for more information.
- Time-based scheduling: You can program a schedule in which every day is different, a schedule where weekdays and weekends are different or a schedule where every day is the same. There are four adjustable periods per day: Wake, Away, Home and Sleep. See "[Scheduling](#)" on page 76 for more information.
- No schedule: You can also choose to disable schedule and adjust the thermostat manually. See "[Main Menu](#)" on page 80.
- Tip: The First Alert or Resideo app can be used to manage multiple thermostats and multiple users in a household.
- Smart Alerts: T10 or T10+ Smart Thermostat can send alerts for occurrences such as extreme indoor temperatures and reminders for filter changes and other required maintenance.
- Auto change from Heat to Cool: When Auto mode is selected, the T10 or T10+ Smart Thermostat can automatically determine whether your home needs heating or cooling to reach the desired temperature.
- Adaptive Intelligent Recovery: T10 or T10+ Smart Thermostat learns your heating and cooling cycle times to make sure the system delivers the temperature you want, when you want it.

Apple® HomeKit™ Setup Code

The T10 or T10+ Smart Thermostat supports HomeKit. At thermostat, select the **MENU** icon at bottom of screen. Then choose **HomeKit Setup** from the options and follow the instructions (see "[Apple® HomeKit™ Setup](#)" on page 86).

SPECIFICATIONS

T10 & T10+ Thermostat Description.

Feature	Description
Powering Method	Common wire required
Stages: Up to 3H/2C* Heat pump Up to 2H/2C* conventional Radiant floor with slab sensor (T10+ only)	Equipment type: <ul style="list-style-type: none"> • Dual fuel • Hot water, steam, or hot water coil • Gas or oil furnace • High-efficiency or mid-efficiency • Cool only • Humidifier, Dehumidifier, or Ventilator control**
Changeover	Manual or Auto Changeover Selectable
System Setting	Em Heat-Heat-Off-Cool-Auto
Fan Setting	Auto-On-Circ. Multiple speed settings for 2-pipe or 4-pipe fan coil units

*4H/2C heat pump or 3H/4C conventional with T10+ & EIM.

** T10+ with EIM can control three IAQ devices.

Electrical ratings of T10 or T10+ Without EIM.

Terminal	Voltage (50/60Hz)	Running Current
W (Heat)	20-30 VAC	0.02-1.0 A
W2 (Aux) Heat	20-30 VAC	0.02-1.0 A
E (Emergency Heat)	20-30 VAC	0.02-0.5 A
Y (Compressor Stage 1)	20-30 VAC	0.02-1.0 A
Y2 (Compressor Stage 2 or stage 2 fan)	20-30 VAC	0.02-1.0 A
G (Fan)	20-30 VAC	0.02-0.5 A
O/B (Changeover)	20-30 VAC	0.02-0.5 A
L/A (Typically Heat Pump Fault)	20-30 VAC	0.02-0.5 A
U (Hum, Dehum, or Vent)	20-30 VAC	0.02-0.5 A

Electrical ratings of EIM (for use with T10+ models).

Terminal	Voltage (50/60Hz)	Max. Current Rating
O/B	18-30 VAC	1.00 A
Y (Compressor Stage 1)	18-30 VAC	1.00 A
Y2 (Compressor Stage 2 or stage 2 fan)	18-30 VAC	1.00 A
G (Fan)	18-30 VAC	0.50 A
W1	18-30 VAC	0.60 A
W2/Aux 1 (Heating)	18-30 VAC	0.60 A
W3/Aux 2 (Heating)	18-30 VAC	0.60 A
L (Input only)	18-30 VAC	0.60 A
U1, U1 U2, U2 U3, U3	18-30 VAC	0.50 A

Power Consumption: 3VA

RedLINK Communication:

Frequency: 900 MHz frequency range

Re-Sync Time: RedLINK devices re-establish communication within 6 minutes after AC power resumes.

Temperature Setting Range:

Heating: 40 to 90 °F (4.5 to 32 °C).

Cooling: 50 to 99 °F (10 to 37 °C).

NOTE: Adjustable high and low range-stop settings.

Humidification Setting Range:

0% to 90% RH.

Dehumidification Setting Range:

10% to 100% RH.

Humidity Display Range:

0% to 99%.

Humidity Sensor Accuracy:

± 5% RH from 30% to 50% RH at 75 F.

Cool Indication:

Display floods blue and says "Cooling to" when Cool is on.

Heat or Em Heat Indication:

Display floods orange and says "Heating to" when Heat is on.

AUX Heat Indication:

Display shows "Aux Heat On" above the room temperature.

Interstage Differential:

Comfort (default setting):

The thermostat keeps the indoor temperature within 1 degree of the setpoint (Differential less control). Unless the system is dual fuel, or a Differential setting is used, the thermostat turns on stage 2 when the capacity on stage 1 reaches 90%.

- See **ISU 3030** for cool differential options.
- See **ISU 3050** and **ISU 3090** for Backup Heat Differential options.

Clock Accuracy:

1 minute per month at 77 °F (25 °C). ± 2 minutes per month over the operating ambient temperature range. Automatically updates when connected to WiFi router and registered to account.

Mounting Means:

Thermostat mounts directly on the wall in the living space using mounting screws and anchors provided. Can mount to a horizontal 2 x 4 in. junction box using J-Box adapter (included).

Model Numbers

T10 Thermostats and Accessories (No longer available)

Product	Part Number	Operating Ambient Temperature	Operating Relative Humidity	Shipping Temperature	Dimensions in inches (mm)	Color
T10 thermostat	THX321WF2003W	T10 Thermostat 37 to 102 °F (2.8° to 38.9° C)	5% to 90% Non Condensing	-20 to 120 °F 28.9 to 48.9 °C	T10 Thermostat 4.9" H x 3.7" W x 0.93" D (125.4 H x 94.1 W x 23.68 D)	White
Kit with T10 thermostat with one C7189R2002 sensor	THX321WFS2001W					
Wireless indoor temperature, humidity, & motion sensor. Up to 20 per T10 thermostat (IAS) (We are transitioning to C7189R3002 sensors for all T10 models)	C7189R2002-2 (2 pack)	*0 to 120 °F (-17.8° to 48.9°C)	5% to 90% Non-Condensing	-20 to 120 °F (-28.9 to 48.9 °C)	2.6" W x 2.6" H x .78" D (66.25 W x 66.25 H x 19.7 D)	White

* For optimal battery life, operating temperature range of 35 to 114 °F (1.7 to 45.6 °C) is recommended.

T10+ and Accesories

Product	Part Number	Operating Ambient Temperature	Operating Relative Humidity	Shipping Temperature	Dimensions in in. (mm)	Color
T10+ thermostat	THX321WF3003W	T10 + 37 to 102 °F. (2.8 to 38.9 °C)	5% to 90% Non-Condensing	-20 to 120 °F (-28.9 to 48.9 °C)	T10+ 4.9" H x 3.7" W x 0.93" D (125.4mm H x 94.1mm W x 23.68mm D)	White
Kit with T10+ thermostat with one C7189R3002 sensor	THX321WFS3001W					
Kit with T10+ Thermostat, EIM, IAS, RATS/DATS	YTHM1004R3000					
Kit with T10+ Thermostat, EIM, IAS, RATS/DATS, OAS	YTHM1004R3001					
Wireless indoor temperature, humidity, & motion sensor. Up to 20 per T10+ thermostat. (IAS)	C7189R3002-2 (2-pack)	*0 to 120 °F (17.8 to 48.9 °C)	5% to 90% Non-Condensing	-20 to 120 °F (-28.9 to 48.9 °C)	2.6" W x 2.6" H x 0.78" D (66.25 W x 66.25 H x 19.7 D)	White
Wireless outdoor temperature & humidity sensor (OAS)	C7089R3013	-40 to 140 °F (-40 to 60 °C)	0% to 90% Non-Condensing	-40 to 140 °F (-40 to 60 °C)	5" x 3-1/2" x 1-11/16" (127 x 89 x 43)	Grey
Equipment Interface Module (EIM)	THM04R3000	-40 to 165 °F (-40 to 73.9 °C)	5% to 95% Non-Condensing	-20 to 165 °F (-28.9 to 73.9 °C)	4-53/64" W x 9-11/32" H x 1-19/32" D (123 W x 237 H x 41 D)	Grey
Floor/Slab sensor for radiant floor heat (T10+ only. 10K ohm)	AC112-01					
Discharge or return sensor. (Two are included with the T10+ & EIM kits)	C7735A1000					

* For optimal battery life, operating temperature range of 35 to 114 °F (1.7 to 45.6 °C) is recommended.

Accessories for either T10 or T10+

Product	Part Number	Dimensions in in. (mm)
Large Cover Plate & J Box Adapter Included with T10 & T10+ models other than THX321WFS2001W	THP2400A1080	6.11" W x 6.11" H (155.3 X 155.3)
Large molded Cover Plate & J Box Adapter Included with THX321WFS2001W model of T10 & T10+ models	Cannot be ordered as a separate accessory	5-1/2" W x 5-13/64" H (140 x 131)
Wired indoor temperature sensor (10K ohm)	C7189U1005	1-1/2" W x 2-1/4" H x 3/4" D (38 W x 57 H x 19 D)
Wired outdoor temperature sensor (10K ohm)	C7089U1006	2-1/4" W x 3/8" H with 60" lead wires (57 x 10 with 1524 mm lead wires)
Wire saver module or C wire adapter (add a C wire).	Various versions of this made. Starts with THP9045A	

Dimensions

Figure 1: Dimensions of T10 & 10+ thermostat in inches (mm)

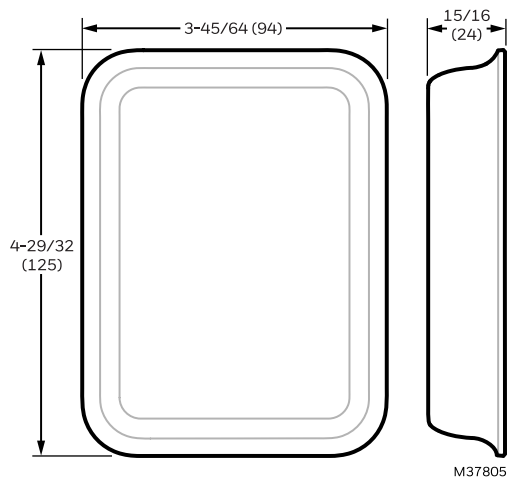

Figure 2: Dimensions of C7189R2002 & C7189R3002 sensors in inches (mm)

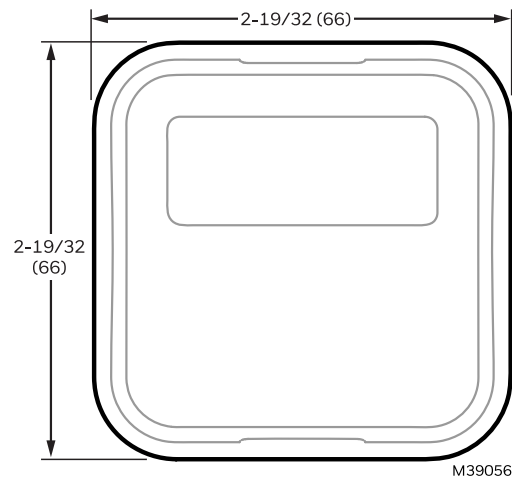

Figure 3: Dimensions of THM04R3000 EIM in inches (mm)

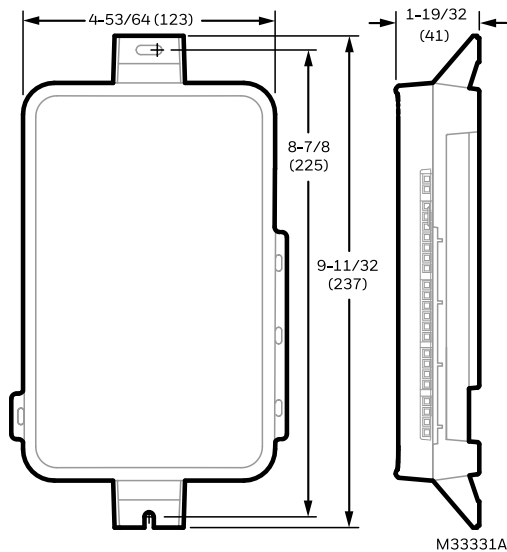

Figure 4: Dimensions of C7089R3013 wireless outdoor sensor in inches (mm)

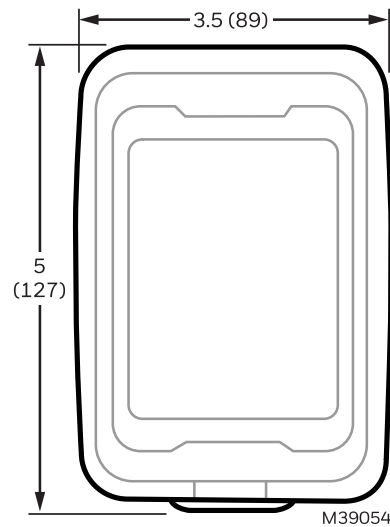

Figure 5: Dimensions of J-Box adapter included with all T10 & T10+ models in inches (mm)

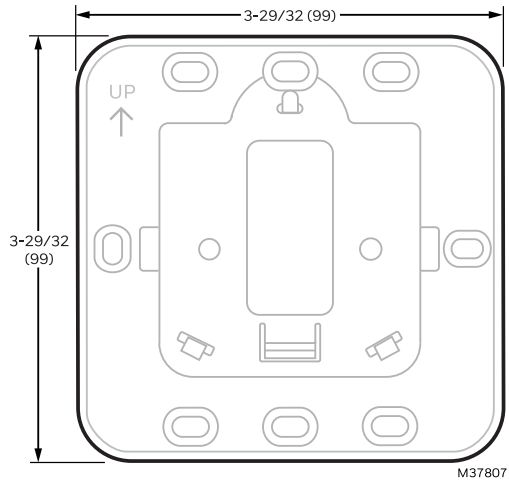

Figure 6: Dimensions of molded grey cover plate included with THX321WFS2001W in inches (mm)

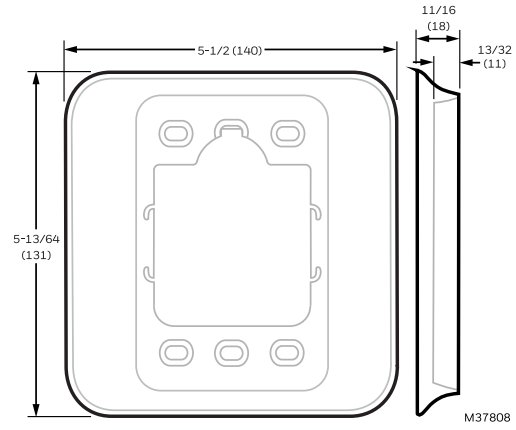
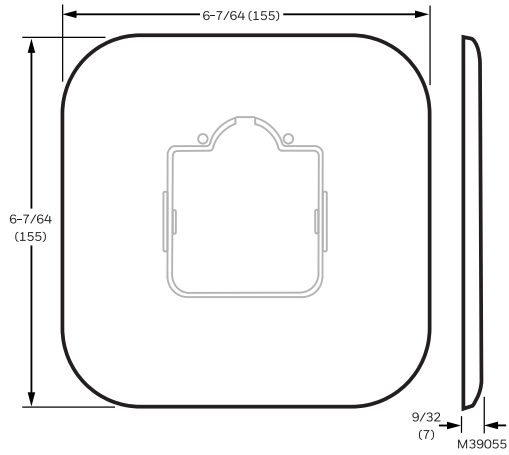

Figure 7: Dimensions of flat white cover plate included with all T10 & 10+ models other than THX321WFS2001W in inches (mm)



SYSTEM INSTALLATION

When Installing This Product...

1. Read these instructions carefully. Failure to follow the instructions can damage the product or cause a hazardous condition.
2. Check the ratings given in the instructions to make sure the product is suitable for your application.
3. Installer must be a trained, experienced service technician.
4. After completing installation, use these instructions to verify the product operation.

Finding Your Date Code

You will need the thermostat Date Code to:

- Add or remove RedLINK 3.0 accessories
- Make changes to Installer Setup
- Perform an Installer Test
- Reset Thermostat to Factory Default Settings

To find the Date Code: Press the **MENU** (three horizontal lines). Scroll down and select **Dealer Information**.



CAUTION: ELECTRICAL HAZARD

Can cause electrical shock or equipment damage. Disconnect power supply before connecting wiring.

Selecting Thermostat Location

Install the thermostat about 5 ft. (1.5m) above the floor in an area with good air circulation at average temperature.

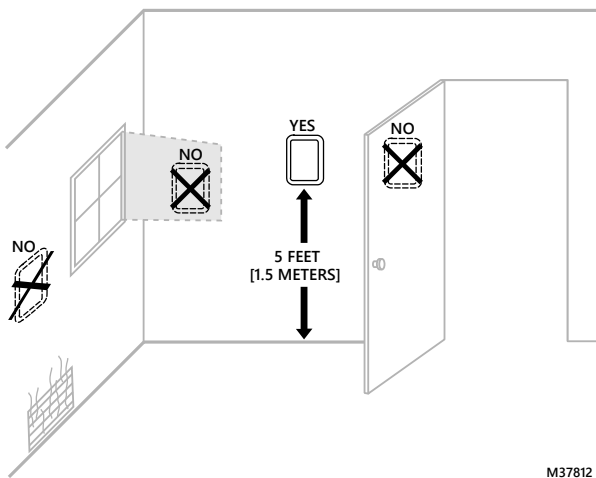

Figure 8: Selecting thermostat location

Do not install the thermostat where it can be affected by:

- Drafts or dead spots behind doors and in corners
- Hot or cold air from ducts
- Radiant heat from sun or appliances
- Concealed pipes and chimneys
- Unheated (uncooled) areas such as an outside wall behind the thermostat

UWP Mounting System Installation

1. Open package to find the UWP. See Step 1 in the image below.
2. Position the UWP on the wall. Level and mark hole positions. See Step 2 in the image below. Drill holes at marked positions, and then lightly tap supplied wall anchors into wall using a hammer. Drill 7/32" holes for drywall.
3. Pull the door open and insert wires through the wiring hole of the UWP. See Step 3 in the image below.

- Place the UWP over the wall anchors. Insert and tighten mounting screws supplied with the UWP. Do not over-tighten. Tighten until the UWP no longer moves. Close the door. See Step 4 in the image below. Use 3x supplied screws #8 1-1/2".

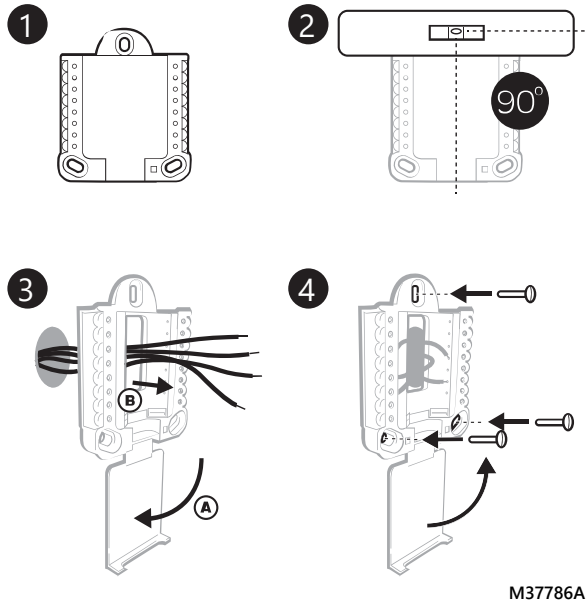

Figure 9: UWP Installation

Optional Decorative Cover Plate Installation

Use the Optional Cover Plate when:

- Mounting the thermostat to an electrical junction box
 - Or when you need to cover paint gap from the old thermostat.
- Separate the Junction Box Adapter from the Cover Plate. See Step 5 in the image below.
 - Mount the Junction Box Adapter to the wall or an electrical box using any of the eight screw holes. Insert and tighten mounting screws supplied with Cover Plate Kit. Do not over-tighten. Make sure the Adapter Plate is level. See Step 6 in the image below. Use 2x supplied screws #6 5/8".
 - Attach the UWP by hanging it on the top hook of the Junction Box Adapter and then snapping the bottom of the UWP in place. See Step 7 in the image below.
 - Snap the Cover Plate onto the Junction Box Adapter. See Step 8 in the image below.

NOTE: Cover plate included with T10 or T10+ can vary by model.

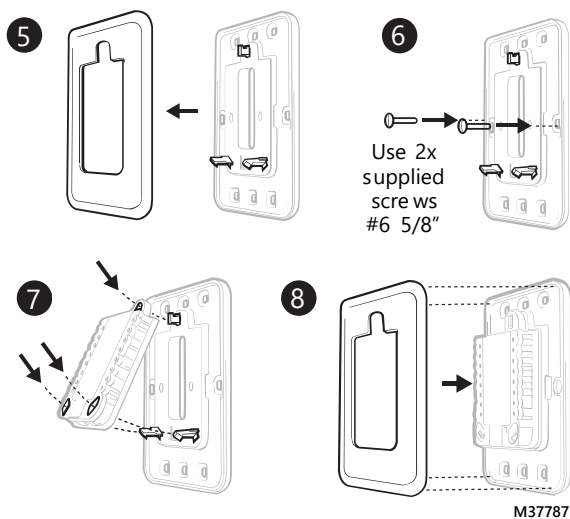

Figure 10: Decorative Cover Plate Installation

Wiring UWP

NOTE: If T10+ & EIM are used, UWP only wires to R and C of a 24 VAC power supply. Usually R and C from UWP goes to R & C at upper right of EIM.

Push down on the tabs to put the wires into the inner holes of their corresponding terminals on the UWP (one wire per terminal) until they are firmly in place.

Gently tug on the wires to verify they are secure.

If you need to release the wires again, push down the terminal tabs on the sides of the UWP. This wiring is just an example, yours may vary.

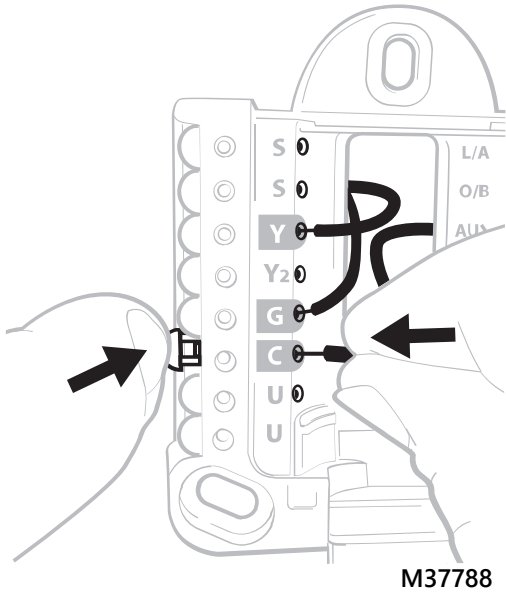

Figure 11: Wiring the UWP

Terminal Designations

Terminals on T10 or T10+ Without EIM

Conventional Systems		Heat Pump Systems	
Terminal	Description	Terminal	Description
S/S	Input for a wired sensor	S/S	Sensor options in charts
Y	Compressor Stage 1	Y	Compressor Stage 1
Y2	Compressor Stage 2	Y2	Compressor Stage 2
G	Fan Relay	G	Fan Relay
C	24VAC Common wire from secondary side of cooling transformer (if 2 transformers)	C	24VAC Common wire from secondary side of cooling transformer
K*	Connect to K on C-wire adapter	K*	Connect to K on C-wire adapter
U/U**	Relay for humidifier, dehumidifier, ventilator, or Economizer	U/U**	Relay for humidifier, dehumidifier, ventilator, or Economizer
L/A	Economizer fault	L/A	Typically used for compressor monitor
W	Heat Stage 1	O/B	Changeover valve for heat pumps
W2	Heat Stage 2	AUX	Backup Heat
		E	Emergency Heat
R	24 VAC Heating transformer	R	24 VAC Heating transformer
Rc	24 VAC Cooling transformer	Rc	24 VAC Cooling transformer

*The THP9045A C-wire adapter is used on heat/cool systems when you only have four wires at the thermostat and you need an extra wire for a common wire. Use the K terminal in place of the Y and G terminals on conventional or heat pump systems to provide control of the fan and the compressor through a single wire the unused wire then becomes the common wire. See THP9045 instructions for more information.

** See note on Wiring U terminals on the following page.

Terminals on THM04R3000 Equipment Interface Module (EIM) Used With T10+ Models Only.

Conventional Systems		Heat Pump Systems	
Terminal	Description	Terminal	Description
S1, S2, S3, S4 (Two of each)	Input for indoor sensor, outdoor sensor, Floor sensor, RATS, DATS, or Dry Contact Alert	S1, S2, S3, S4 (Two of each)	Input for indoor sensor, outdoor sensor, Floor sensor, RATS, DATS, or Dry Contact Alert
Y	Compressor Stage 1	Y	Compressor Stage 1
Y2	Compressor Stage 2	Y2	Compressor Stage 2
G	Fan Relay	G	Fan Relay
C	Common from HVAC transformer when R is jumped to Rc. Common from separate transformer if R is not jumpered	C	Common from HVAC transformer when R is jumped to Rc. Common from separate transformer if R is not jumpered
U1, U2, U3 (Two of each)	Relay for humidifier, dehumidifier, ventilator or Economizer	U1, U2, U3 (Two of each)	Relay for humidifier, dehumidifier, or ventilator or Economizer
L	Economizer fault code	L	Typically used for compressor monitor
O/B	Not used for conventional applications	O/B	Changeover valve for heat pumps
W1	Heat Stage 1	W1	Not used for heat pump applications
W2	Heat Stage 2	AUX1	Stage 1 of AUX/EM heat
W3	Heat Stage 3	AUX2	Stage 2 of AUX/EM heat
R	24V from transformer to power EIM	R	24V from transformer to power EIM
Rc	24 VAC Cooling transformer	Rc	24 VAC Cooling transformer
Rh	24 VAC Heat transformer	Rh	24 VAC Heat transformer

2-Pipe Fan Coil Unit Terminals

Supported by T10+ with firmware 03.03.08.02 or later and EIM (if used) with firmware 01.02.01.00 or later

2-pipe fan coil unit terminals at thermostat/UWP when EIM is not used with T10+

Terminal	Description
Rc R	R and Rc are usually jumpered together (slider switch up) on a 2-pipe FCU with the 24 VAC hot to R . If the Aux Heat is powered by a separate transformer you may slide the R/Rc switch down, then aux heat is wired to R and Aux . FCU is wired to Rc , C , Y , G , etc.
C	24 VAC common from fan coil unit transformer
Y	Heat/Cool relay
W	Not used on 2-pipe fan coil unit
G	Low speed fan
Y2	Medium speed fan
U (upper U terminal)	High speed fan. U slider switch must be up
Aux / W2	Auxiliary Heat (Some 2-pipe fan coil units do not have auxiliary heat)
S, S*	Optional wired 10K/20K pipe sensor for changeover
L/A - A*	Dry contact switch for pipe changeover from Heat to Cool
O/B	Not used on 2-pipe fan coil unit
*The T10+ uses either a wired 10K or 20K pipe sensor to the S terminals, or a dry contact switch to L/A to tell the T10+ whether the pipe is hot or cold. The ISU settings allow you to choose the method being used. If a dry contact switch is wired to L/A, the T10+ allows you to use the S terminals for a wired indoor or outdoor sensor.	

2-pipe fan coil unit terminals when EIM is is used with T10+

Terminal	Description
R Rc Rh	Typically R , Rh and Rc would be jumpered together for a 2-pipe fan coil unit with that transformer wired to R and C . If jumpers are removed, R and C power the EIM, Rc is the 24 volt hot from fan coil unit. Rh and Aux may be used for an auxiliary heat source if that source is powered by a separate transformer. If using the L/A for Heat/Cool changeover, R and Rc must be jumpered
C	24 VAC common from the transformer powering the fan coil unit.
Y	Heat/Cool relay
W	Not used on 2-pipe fan coil unit
G	Low speed fan
Y2	Medium speed fan
U1, U2, U3	High speed fan. During setup, select which U contacts are used for this. Jumper one of the U terminals from the set selected to R as shown in wiring diagrams
Aux1	Auxiliary Heat (Some 2-pipe fan coil units don't have Auxiliary Heat)
S1, S2, S3, S4*	Optional wired 10K/20K pipe sensor for changeover the Set of S terminals used for this is selected during setup. The other 3 sets of S terminals could be used for an optional 10K/20K wired indoor sensor, 10K wired outdoor sensor, dry contact alert, or remote setback with dry contact occupancy sensor
L*	Dry contact switch for pipe changeover from Heat to Cool
OB	Not used on 2-pipe fan coil unit
* The T10+ uses either a wired 10K or 20K pipe sensor to the S terminals, or a dry contact switch to L/A to tell the T10+ whether the pipe is hot or cold. The ISU settings allow you to choose the method being used. If a dry contact switch is wired to L/A, the T10+ allows you to use the S terminals for a wired indoor or outdoor sensor.	

4-Pipe Fan Coil Unit Terminals

Supported by T10+ with firmware 03.03.08.02 or later and EIM (if used) with firmware 01.02.01.00 or later

4-pipe fan coil unit terminals at thermostat /UWP when EIM is not used with T10+

Terminal	Description
R Rc	R and Rc must be jumpered together (slider switch up) on a 4-pipe FCU with the 24 VAC hot from FCU transformer to R. If the Aux Heat is powered by a separate transformer an isolation relay will be needed from the Aux terminal on UWP
C	24 VAC common from fan coil unit transformer
Y	Cool relay
W	Heat relay
G	Low speed fan
Y2	Medium speed fan
U (Upper U terminal)	High speed fan. U slider switch must be up
Aux/W2	Auxiliary Heat
S,S	Optional 10K/20K wired indoor sensor or 10K wired outdoor sensor
L/A - A	Optional remote setback switch
O/B	Not used on 4-pipe fan coil unit

4-pipe fan coil unit terminals when EIM is used with T10+

Terminal	Description
R Rc Rh	Typically R/Rh/Rc terminals are all jumpered together for this application. Rh, and Rc must be jumpered together for a 4-pipe fan coil unit. The R jumper may be removed to power the EIM with a separate transformer unless the L is used for changeover. If Aux Heat is powered off a separate transformer, an isolation relay would be needed.
C	24 VAC common from the transformer powering the fan coil unit.
Y	Cool relay
W	Heat relay
G	Low speed fan
Y2	Medium speed fan
U1, U2, U3	High speed fan. During setup, select which U contacts are used for this. Jumper one of the U terminals from the set selected to R as shown in wiring diagrams. Additional U contacts can be used for humidifier, dehumidifier, or ventilator
Aux1	Auxiliary Heat (Some 4-pipe fan coil units don't have auxiliary heat)
S1, S2, S3, S4	Any set of S terminals can be used for an optional 10K/20K wired indoor sensor, a 10K wired outdoor sensor, dry contact alerts, or remote setback with dry contact occupancy sensor.
O/B	Not used on 4-pipe fan coil unit

Setting Slider Tabs

Set R Slider Tab

- Use built-in jumper (**R Slider Tab**) to differentiate between one or two transformer systems.
- If there is only one R wire, and it is connected to the **R**, **Rc**, or **RH** terminal on the old thermostat, set the slider to the **up** position (**1 wire**).
- If there is one wire connected to the **R** terminal and one wire connected to the **Rc** terminal, set the slider to the **down** position (**2 wires**).

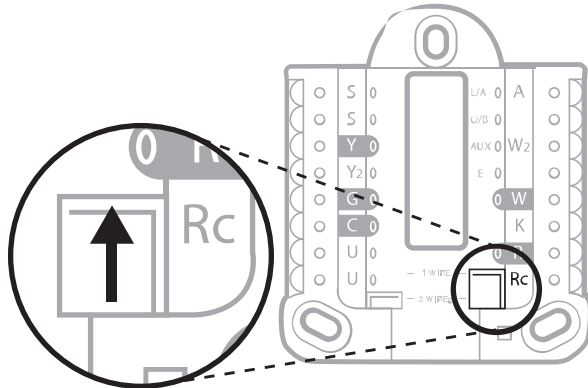

M37789

Figure 12: Setting the R Slider tab

Set U Slider Tab

- Use built-in jumper (U Slider Tab) for IAQ device.
- When the **U Slider Tab** is in the down position (**2 wires**) the U contacts are a dry set of contacts.
- If your IAQ device is powered by the cooling transformer, move the **U Slider Tab** to the up position (1 wire). When this is done, the lower U terminal is internally jumped to the Rc terminal. In this application, you would hook up one wire from your IAQ device to the upper U terminal and the other to the common side of the cooling transformer. The 1 wire setting is most commonly used when using a fresh air damper for ventilation or using low speed fan for dehumidification.
- See "[Wiring Diagrams](#)" on the next page.

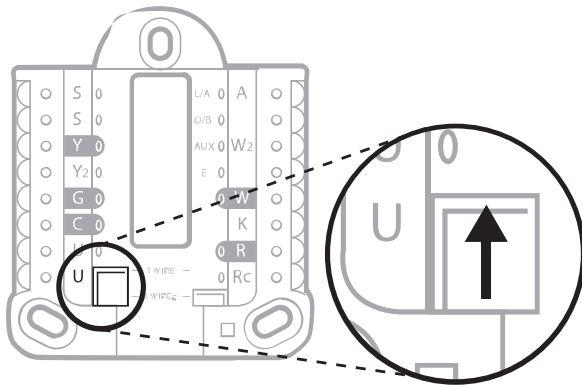

M37790

Figure 13: Setting the U Slider Tab

WIRING DIAGRAMS

1. Use 18- to 22- gauge thermostat wire. Shielded cable is not required.
2. Set the R Slider Tab on the UWP to the up position (1 wire) for 1 transformer systems or the down position (2 wires) for 2 transformer systems. See ["Setting Slider Tabs" on the previous page.](#)
3. Set the U Slider Tab as shown in the diagrams.
4. When T10+ is used with THM04R3000 EIM, wire only R and C to T10+ to power the thermostat. Then follow the wiring diagrams included in EIM literature.

Wiring at T10 or T10+ without EIM

Figure 14: Heat only: Gas or oil furnace

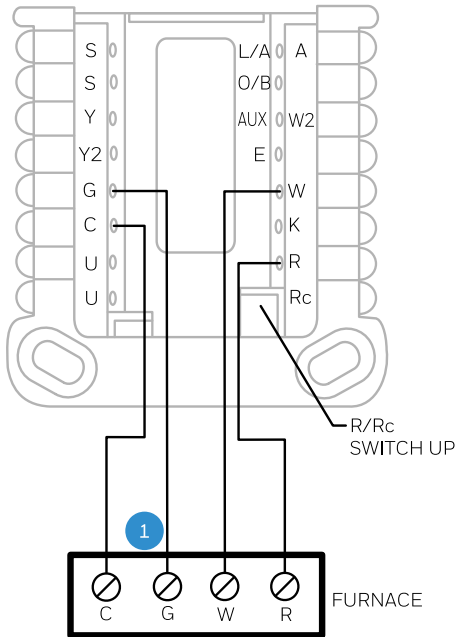

MCR39490

- 1 G USED FOR INDEPENDENT FAN CONTROL ONLY. MOST HEAT ONLY, GAS OR OIL FORCED AIR SYSTEMS DO NOT USE A FAN (G) WIRE.

Figure 15: Cool only

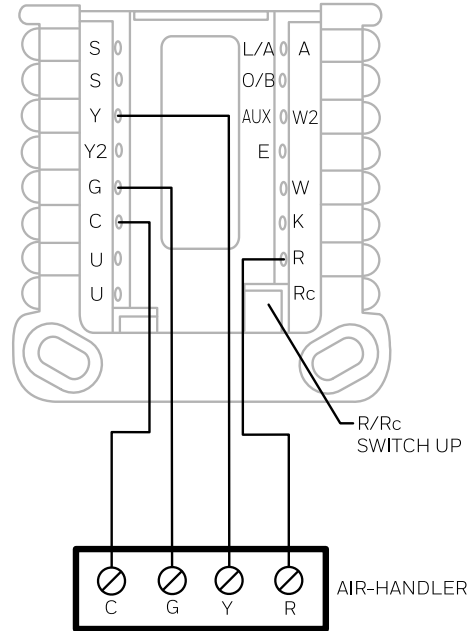

MCR39491

Figure 16: 1H/1C gas furnace

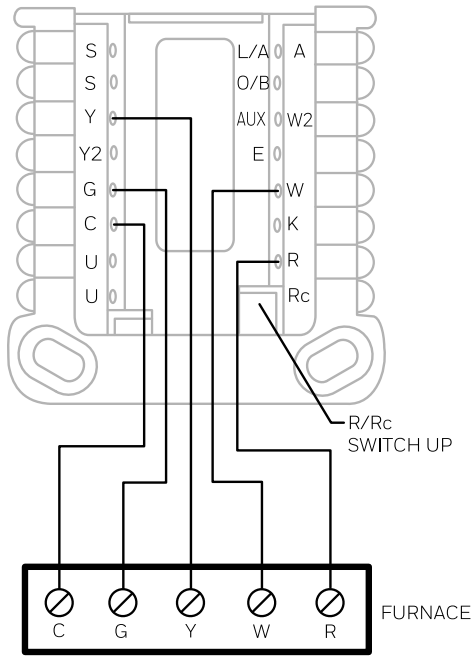

MCR39493

Figure 17: 2H/1C gas furnace

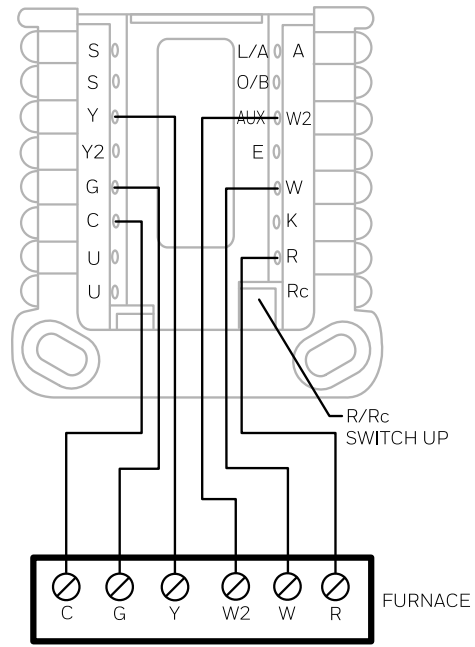

MCR39496

Figure 18: 2-transformer system; 1H/1C oil furnace

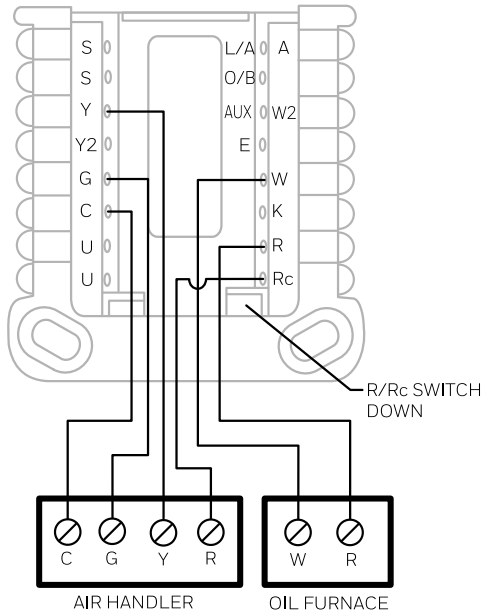

MCR39494

Figure 19: 2-transformer system; hot water heat with air-conditioning (or hot water coil)

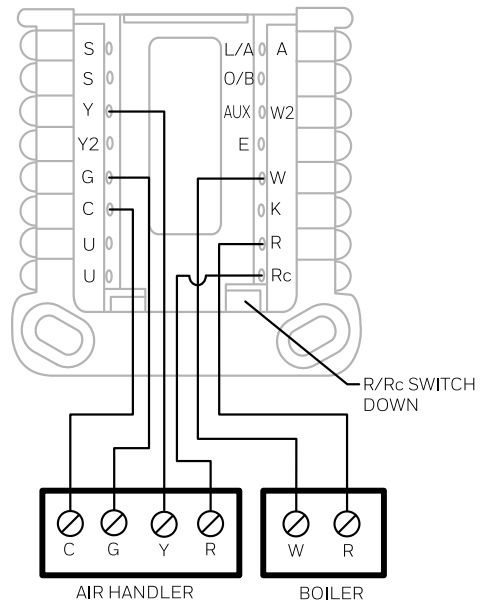

MCR39495

Figure 20: Hot water heat with power open zone valve

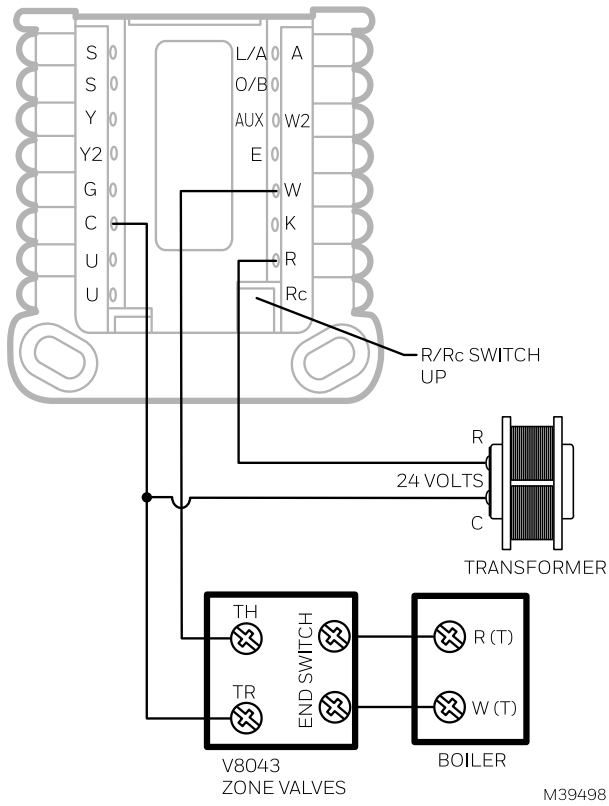

Figure 21: Hot water boiler, heat only

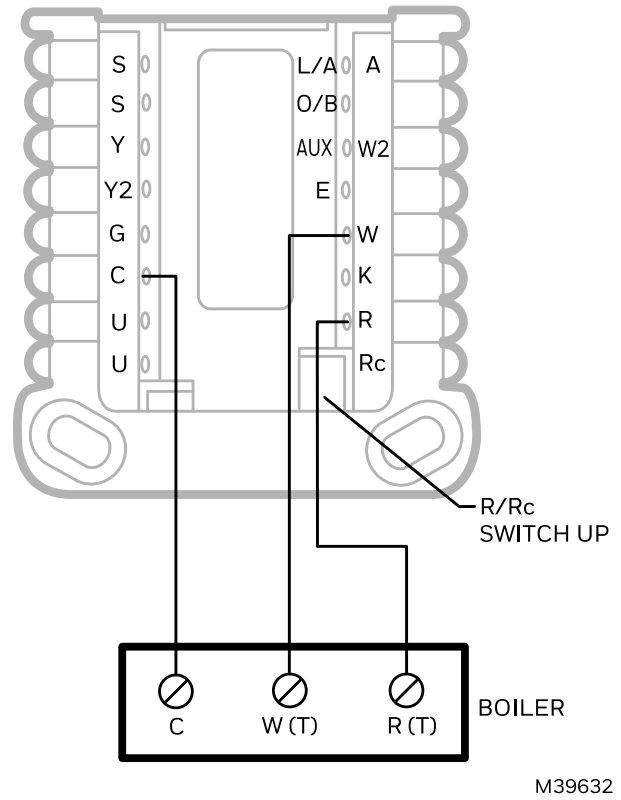

Figure 22: Series 20 valve (power open and power closed)

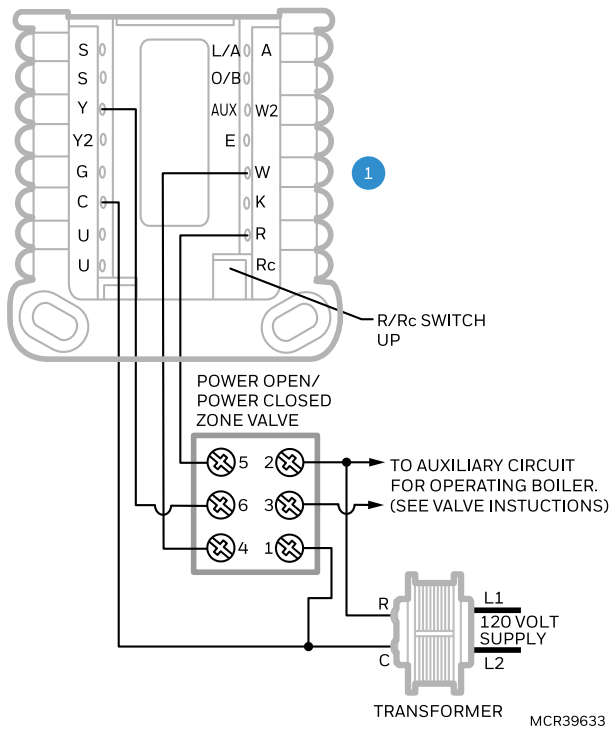
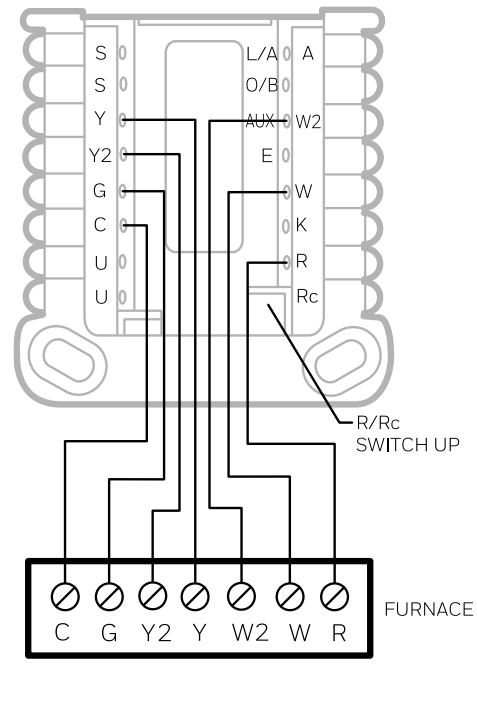
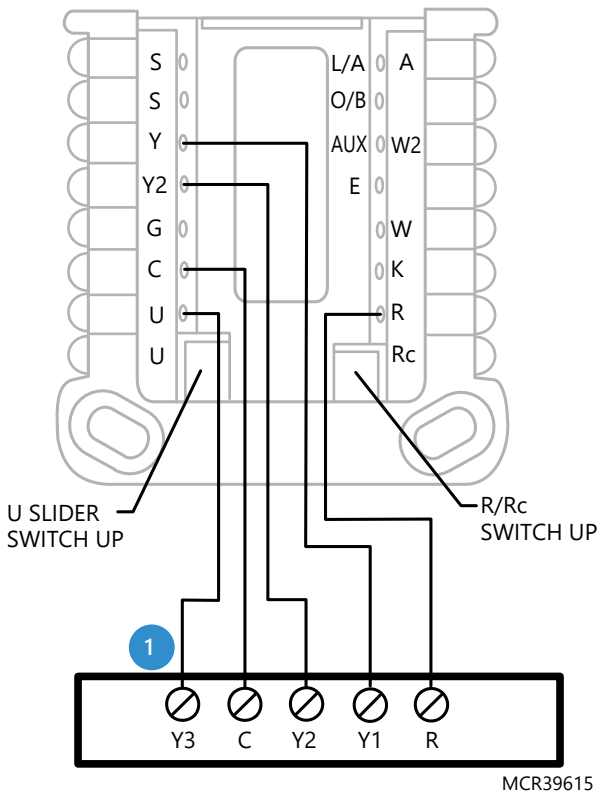

Figure 23: 2H/2C Gas Furnace



1 THERMOSTAT MUST BE CONFIGURED FOR RADIANT HEAT WITH 0 (ZERO) COOL STAGES.

Figure 24: Wiring a third Cool stage without EIM



1 G, W, W2, ETC. ARE WIRED AS NORMAL.

Figure 25: 1H/1C Heat Pump without Aux Heat

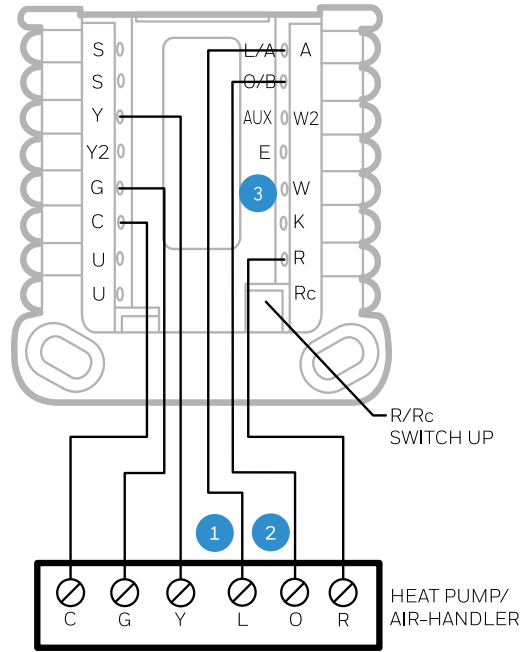

MCR39500

- 1 L ONLY CONNECTED IF HEAT PUMP HAS A FAULT TERMINAL.
- 2 SOME HEAT PUMPS USE B RATHER THAN O FOR REVERSING VALVE.
- 3 **IMPORTANT: DO NOT CONNECT ANY WIRE TO W FOR HEAT PUMP APPLICATIONS! THIS CAN CAUSE HEAT TO RUN CONTINUOUSLY.**

Figure 26: 2H/1C Heat Pump with Electric Aux Heat

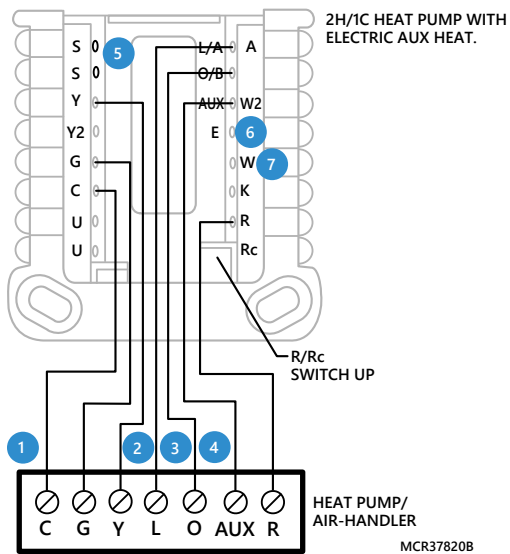

- 1 COMMON REQUIRED.
- 2 L ONLY CONNECTED IF HEAT PUMP HAS A FAULT TERMINAL.
- 3 SOME HEAT PUMPS USE B RATHER THAN O FOR REVERSING VALVE.
- 4 DIFFERENT HEAT PUMP MODELS LABEL THE AUXILIARY HEAT TERMINAL DIFFERENTLY THAN SHOWN. CONSULT HEAT PUMP WIRING GUIDE.
- 5 LOCKOUT OF AUX HEAT ON HIGH OUTDOOR TEMPERATURE CAN BE DONE THROUGH ROUTER/INTERNET CONNECTION AND APP, WIRED OUTDOOR SENSOR OR WIRELESS OUTDOOR SENSOR.
- 6 MOST HEAT PUMPS SHARE THE SAME SET OF HEAT STRIPS FOR AUX AND EM HEAT. IN THOSE CASES E ISN'T USED. IF SEPARATE AUX AND E WIRES ARE USED, WIRE ONE SET OF STRIPS TO E TO BE ENERGIZED IN EM HEAT AND A DIFFERENT SET OF STRIPS TO AUX TO BE ENERGIZED IN AUX HEAT.
- 7 **IMPORTANT: DO NOT CONNECT ANY WIRE TO W FOR HEAT PUMP APPLICATIONS! THIS CAN CAUSE HEAT TO RUN CONTINUOUSLY..**

Figure 27: 2H/2C Heat pump without Aux Heat

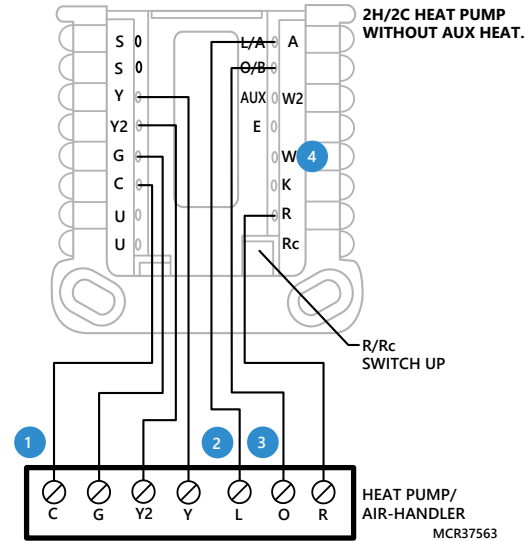

- 1 COMMON REQUIRED
- 2 L ONLY CONNECTED IF HEAT PUMP HAS A FAULT TERMINAL.
- 3 SOME HEAT PUMPS USE B RATHER THAN O FOR REVERSING VALVE.
- 4 **IMPORTANT: DO NOT CONNECT ANY WIRE TO W FOR HEAT PUMP APPLICATIONS! THIS CAN CAUSE HEAT TO RUN CONTINUOUSLY.**

Figure 28: 3H/2C Heat pump with electric Aux Heat

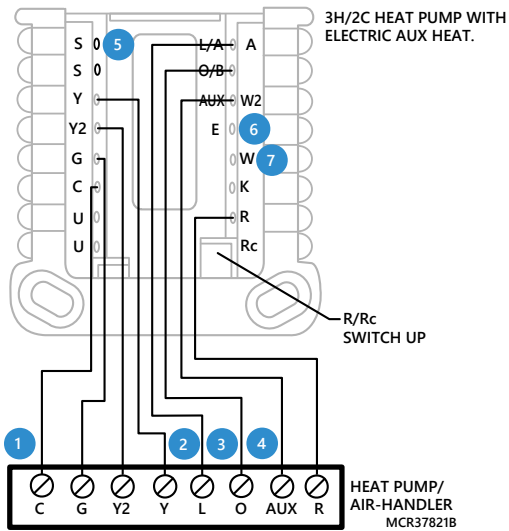

- 1 COMMON REQUIRED.
- 2 L ONLY CONNECTED IF HEAT PUMP HAS A FAULT TERMINAL.
- 3 SOME HEAT PUMPS USE B RATHER THAN O FOR REVERSING VALVE.
- 4 DIFFERENT HEAT PUMP MODELS LABEL THE AUXILIARY HEAT TERMINAL DIFFERENTLY THAN SHOWN. CONSULT HEAT PUMP WIRING GUIDE.
- 5 LOCKOUT OF AUX HEAT ON HIGH OUTDOOR TEMPERATURE CAN BE DONE THROUGH ROUTER/INTERNET CONNECTION AND APP, WIRED OUTDOOR SENSOR OR WIRELESS OUTDOOR SENSOR.
- 6 **IMPORTANT: DO NOT CONNECT ANY WIRE TO W FOR HEAT PUMP APPLICATIONS! THIS CAN CAUSE HEAT TO RUN CONTINUOUSLY..**
- 7 MOST HEAT PUMPS SHARE THE SAME SET OF HEAT STRIPS FOR AUX AND EM HEAT. IN THOSE CASES E ISN'T USED. IF SEPARATE AUX AND E WIRES ARE USED, WIRE ONE SET OF STRIPS TO E TO BE ENERGIZED IN EM HEAT AND A DIFFERENT SET OF STRIPS TO AUX TO BE ENERGIZED IN AUX HEAT.

Figure 29: Dual fuel 2H/1C Heat pump

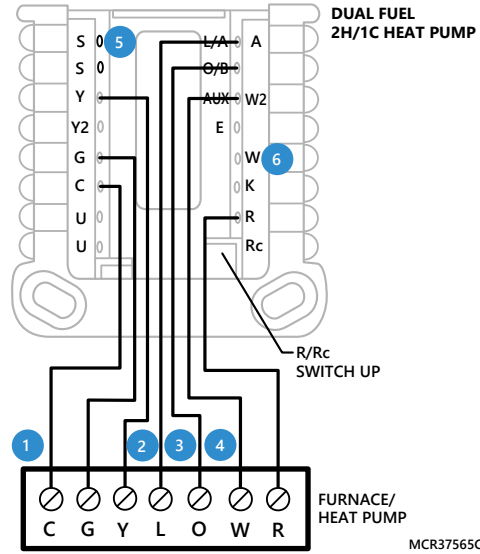

- 1 COMMON REQUIRED
- 2 L ONLY CONNECTED IF HEAT PUMP HAS A FAULT TERMINAL.
- 3 SOME HEAT PUMPS USE B RATHER THAN O FOR REVERSING VALVE.
- 4 THE HEAT PUMP AND FURNACE HAVE SEPARATE BOARDS. THEY ARE SHOWN TOGETHER HERE TO SIMPLIFY THIS DIAGRAM. W IS FROM THE FURNACE BOARD.
- 5 BALANCE POINT LOCKOUT CAN BE DONE THROUGH ROUTER/INTERNET CONNECTION AND APP, WIRED OUTDOOR SENSOR OR WIRELESS OUTDOOR SENSOR.
- 6 **IMPORTANT: DO NOT CONNECT ANY WIRE TO W FOR HEAT PUMP APPLICATIONS! THIS CAN CAUSE HEAT TO RUN CONTINUOUSLY.**

Figure 30: Dual Fuel, 3H/2C Heat Pump

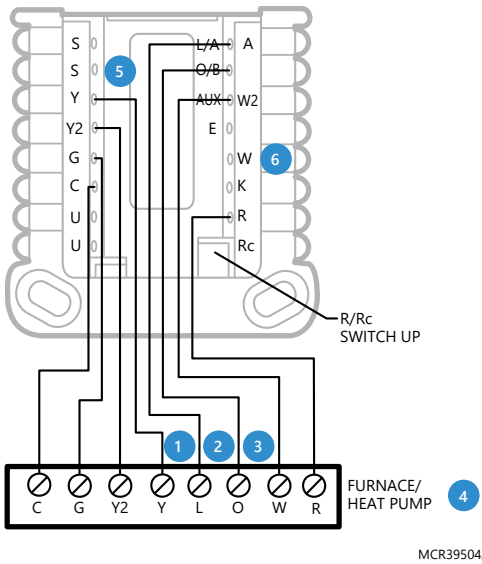

- 1 COMMON REQUIRED.
- 2 L ONLY CONNECTED IF HEAT PUMP HAS A FAULT TERMINAL.
- 3 SOME HEAT PUMPS USE B RATHER THAN O FOR REVERSING VALVE.
- 4 THE HEAT PUMP AND FURNACE HAVE SEPARATE BOARDS. THEY ARE SHOWN TOGETHER HERE TO SIMPLIFY THIS DIAGRAM. **w** IS FROM THE FURNACE BOARD.
- 5 OPTIONAL: C7089U1006 WIRES TO THE TWO **S** TERMINALS.
- 6 **IMPORTANT: DO NOT CONNECT ANY WIRE TO **W** FOR HEAT PUMP APPLICATIONS! THIS CAN CAUSE HEAT TO RUN CONTINUOUSLY..**

Fan Coil Unit Wiring Diagrams without EIM

Figure 31: Typical wiring of 4-pipe fan coil

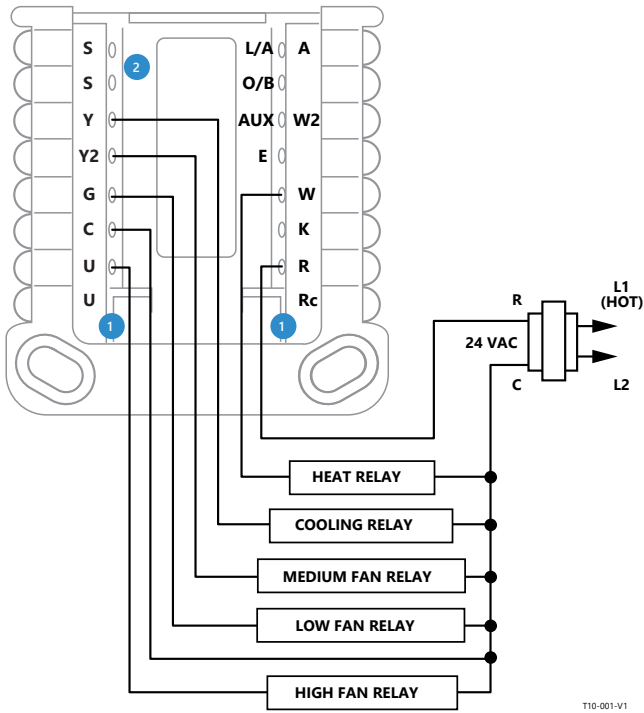

- 1 THE R/RC AND U SLIDER SWITCHES SHOULD BE SET TO THE UP POSITION AS SHOWN.
- 2 S TERMINALS CAN BE USED FOR A WIRED INDOOR SENSOR OR OUTDOOR SENSOR. SEE THE REMOTE SETBACK WIRING OPTIONS IF A SENSOR/SWITCH WAS WIRED TO S TERMINALS ON PREVIOUS THERMOSTAT.

T10-001-V1

Figure 32: Typical wiring of 2-pipe fan coil with reheat using wired 10K/20K Heat/cool changeover pipe sensor

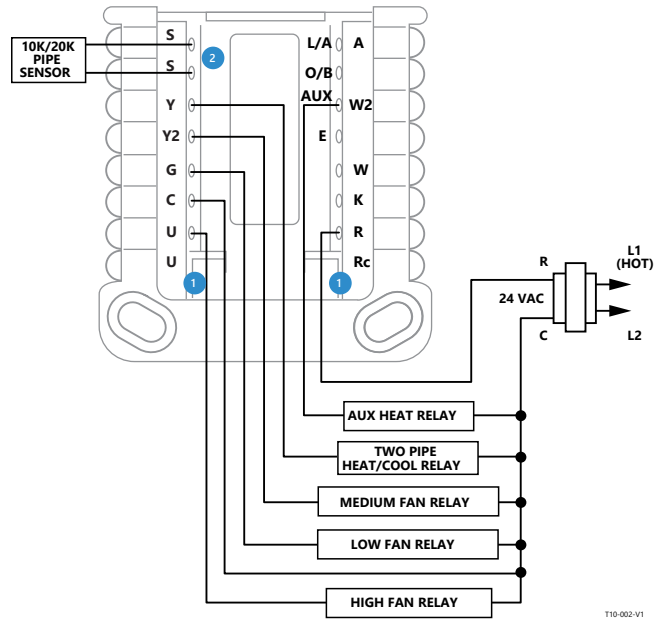

- 1 THE R/RC AND U SLIDER SWITCHES SHOULD BE SET TO THE UP POSITION AS SHOWN.
- 2 S TERMINALS CAN BE USED FOR A WIRED 10K OR 20K PIPE SENSOR FOR HEAT/COOL CHANGEOVER.

T10-002-V1

Figure 33: Typical wiring of 2-pipe fan coil without reheat using wired 10K/20K Heat/Cool changeover pipe sensor

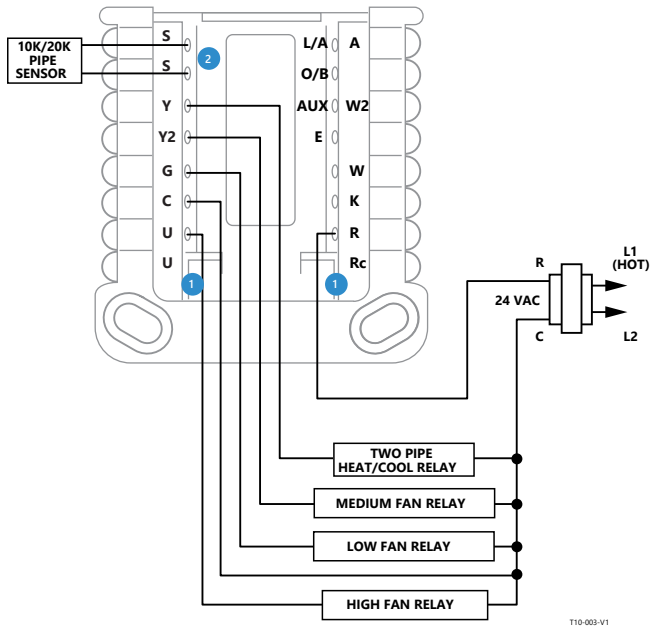

- 1 THE R/Rc AND U SLIDER SWITCHES SHOULD BE SET TO THE UP POSITION AS SHOWN.
- 2 S TERMINALS CAN BE USED FOR A WIRED 10K OR 20K PIPE SENSOR FOR HEAT/COOL CHANGEOVER. SEE THE REMOTE SETBACK WIRING OPTIONS IF A SENSOR/SWITCH WAS WIRED TO S TERMINALS ON PREVIOUS THERMOSTAT.

Figure 34: Typical wiring of 2-pipe fan coil with reheat using dry contact switch for Heat/Cool changeover

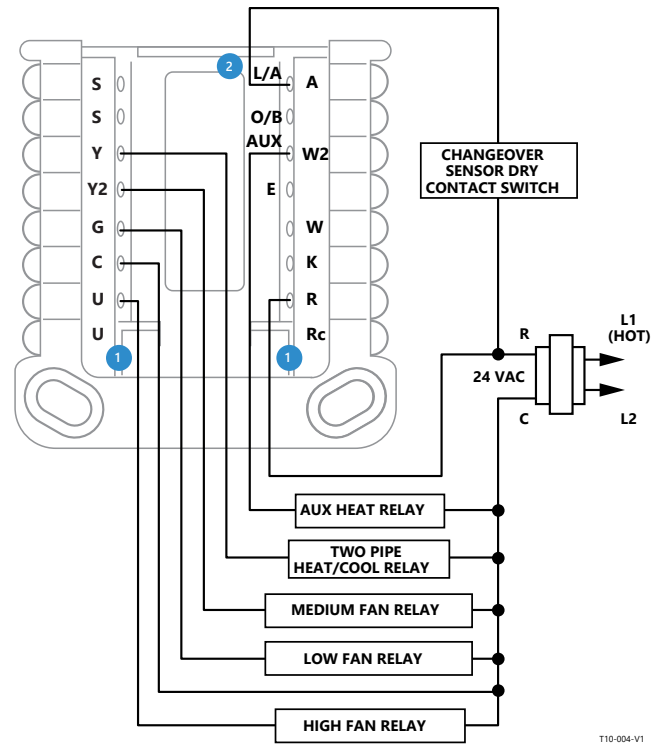

- 1 THE R/Rc AND U SLIDER SWITCHES SHOULD BE SET TO THE UP POSITION AS SHOWN.
- 2 WIRE THE DRY CONTACT CHANGEOVER SWITCH TO R AT THE FAN COIL UNIT AND L AT T10+ AS SHOWN. T10+ CAN BE CONFIGURED FOR THE CHANGEOVER SWITCH TO BE NORMALLY OPEN IN COOL OR HEAT MODE.

Figure 35: Typical wiring of 2-pipe fan coil without reheat using dry contact switch for Heat/Cool changeover

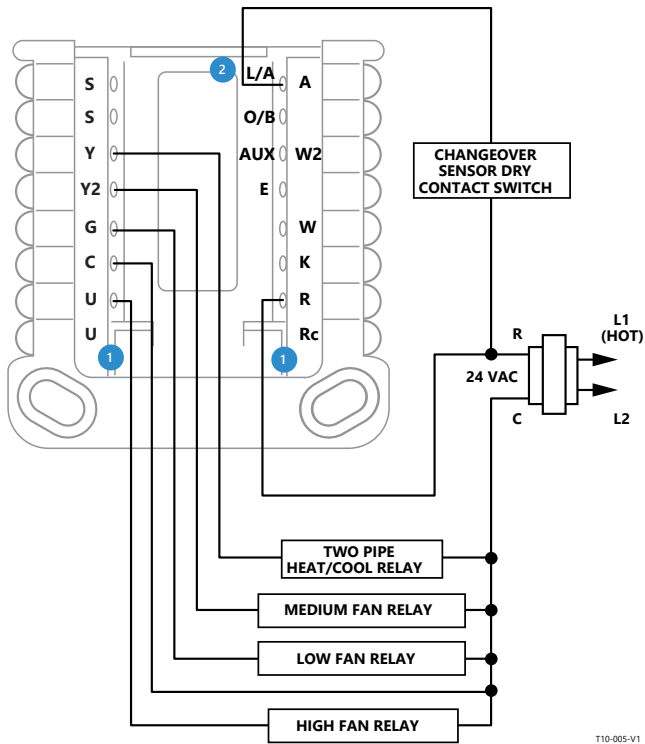

T10-005-V1

- 1 THE R/RC AND U SLIDER SWITCHES SHOULD BE SET TO THE UP POSITION AS SHOWN.
- 2 WIRE THE DRY CONTACT CHANGEOVER SWITCH TO R AT THE FAN COIL UNIT AND L AT T10+ AS SHOWN. T10+ CAN BE CONFIGURED FOR THE CHANGEOVER SWITCH TO BE NORMALLY OPEN IN COOL OR HEAT MODE.

Whole house humidifier, dehumidifier, or ventilator wiring using the U slider tab

Figure 36: Wired to humidifier, dehumidifier, or ventilator with built-in transformer

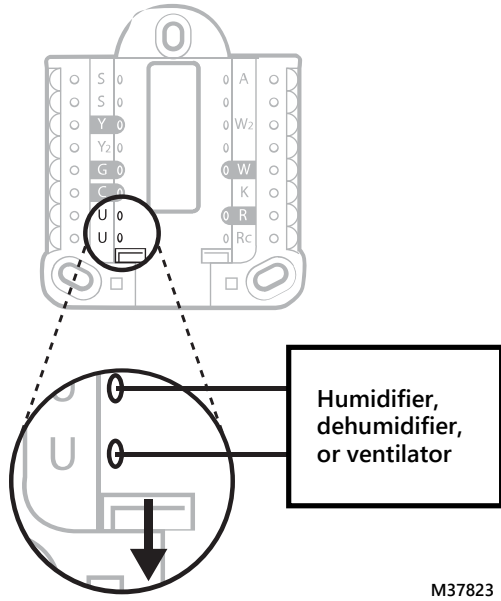

Figure 37: Wired to fresh air damper powered by furnace transformer

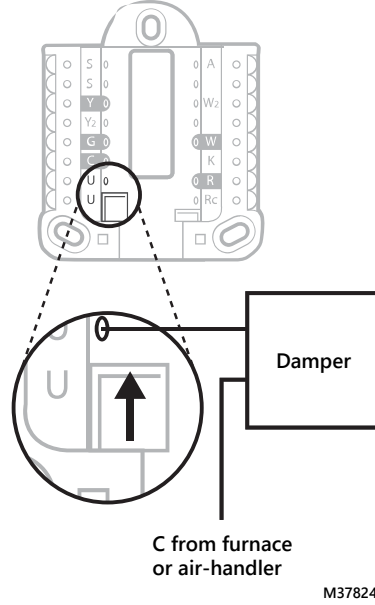

Figure 38: Wired to humidifier, ventilator, or damper powered by external transformer

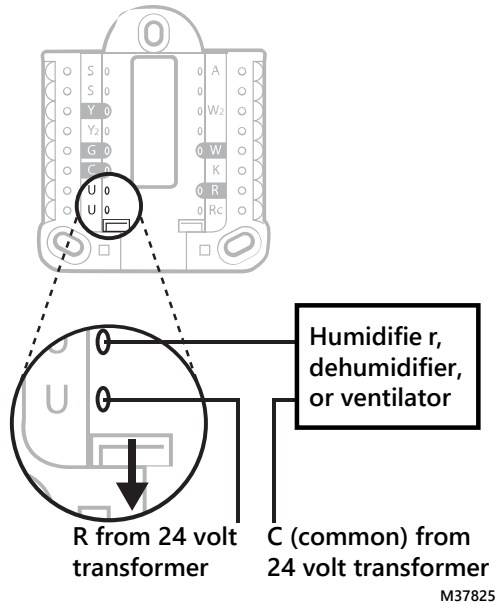
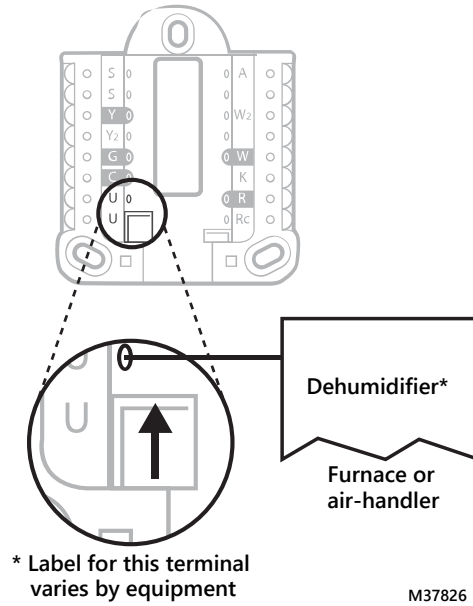

Figure 39: Wired to low speed fan terminal on HVAC for dehumidification



INSTALLING EQUIPMENT INTERFACE MODULE (IF USED)

1. Mount the EIM near the HVAC equipment or on the equipment itself. Use screws and anchors as appropriate for the mounting surface.
2. To wire the EIM, strip 1/4" insulation, then insert wires (For wiring diagrams, see "EIM Wiring Diagrams" below.)

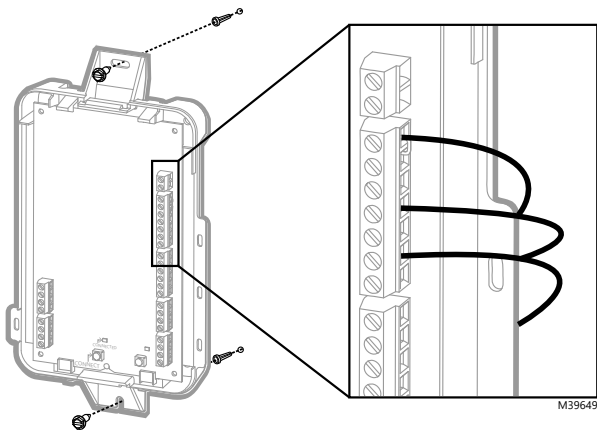
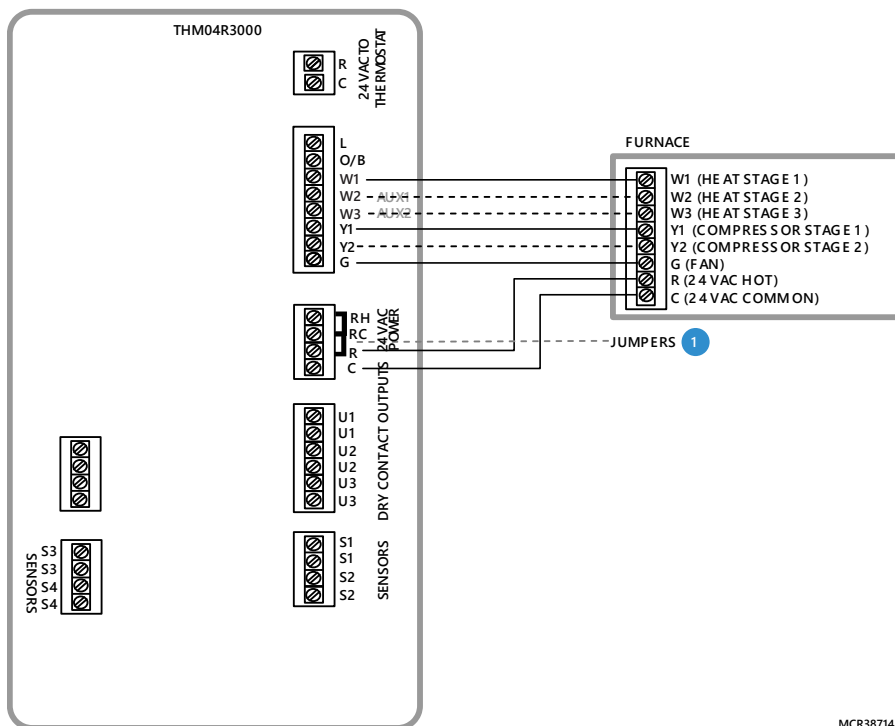

Figure 40: Strip 1/4" insulation, then insert wires as shown.

EIM Wiring Diagrams

Figure 41: Typical wiring of a conventional system with up to 3 stage Heat and 2 stage Cool with one transformer



MCR38714

- 1 Remove jumper(s) if using separate transformers.

NOTE: See following pages for additional thermostat wiring guidelines for other system types, sensor wiring, IAQ Control, and other dry contact wiring options.

Figure 42: Wiring a third cool stage with EIM

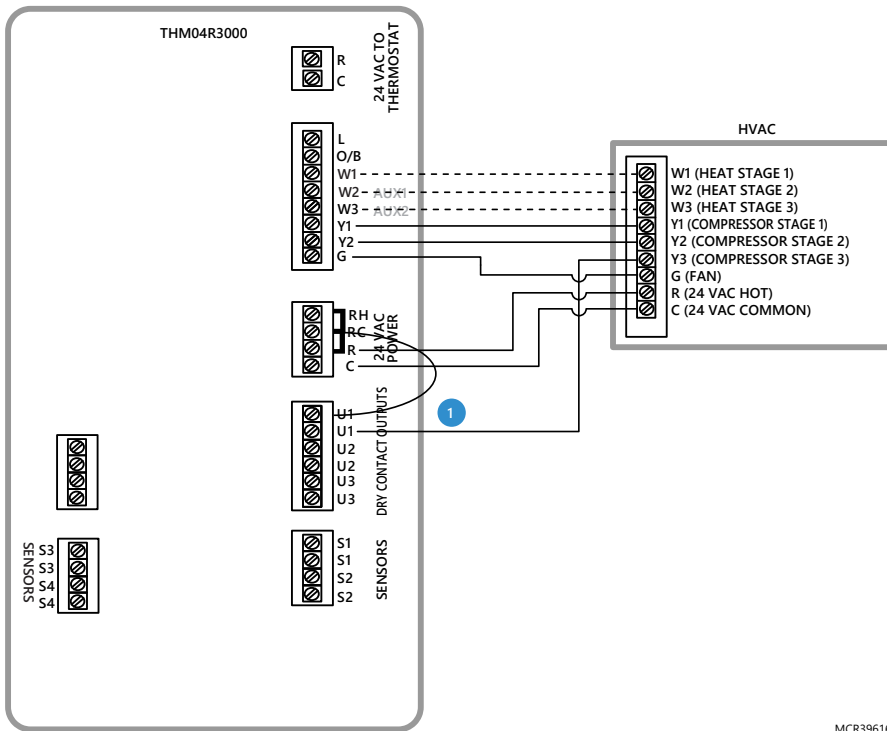

MCR39616

- 1 Any set of U terminals (U1, U2, U3) can be assigned to control stage 3. Jumper the other U from that set to Rc as shown.

Figure 43: Typical wiring of a heat pump system with up to four-stage Heat and two-stage Cool with one transformer

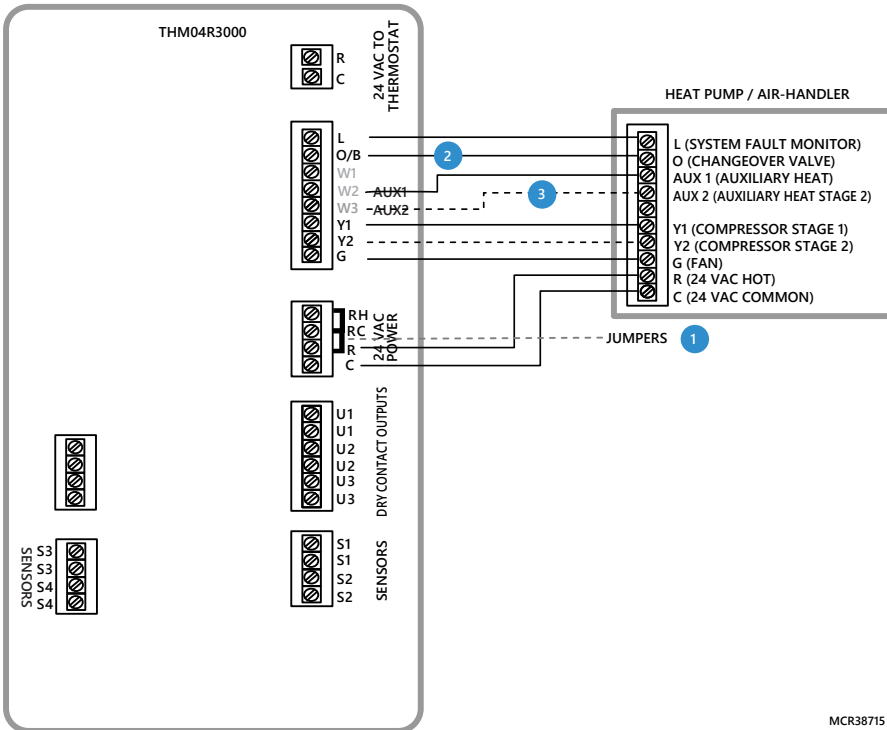

MCR38715

- 1 Remove jumper(s) if using separate transformers.
- 2 The changeover valve will be labeled O if energized in cool or B if energized in heat.
- 3 The Auxiliary heat stage(s) are labeled differently on different heat pump air handlers. Most heat pumps applications only have one stage of auxiliary heat.

NOTE: See following pages for additional thermostat wiring guidelines for other system types, sensor wiring, IAQ Control, and other dry contact wiring options.

Figure 44: Typical wiring of a Dual Fuel heat pump system with 1 or 2-stage furnace and 1 or 2-stage heat pump

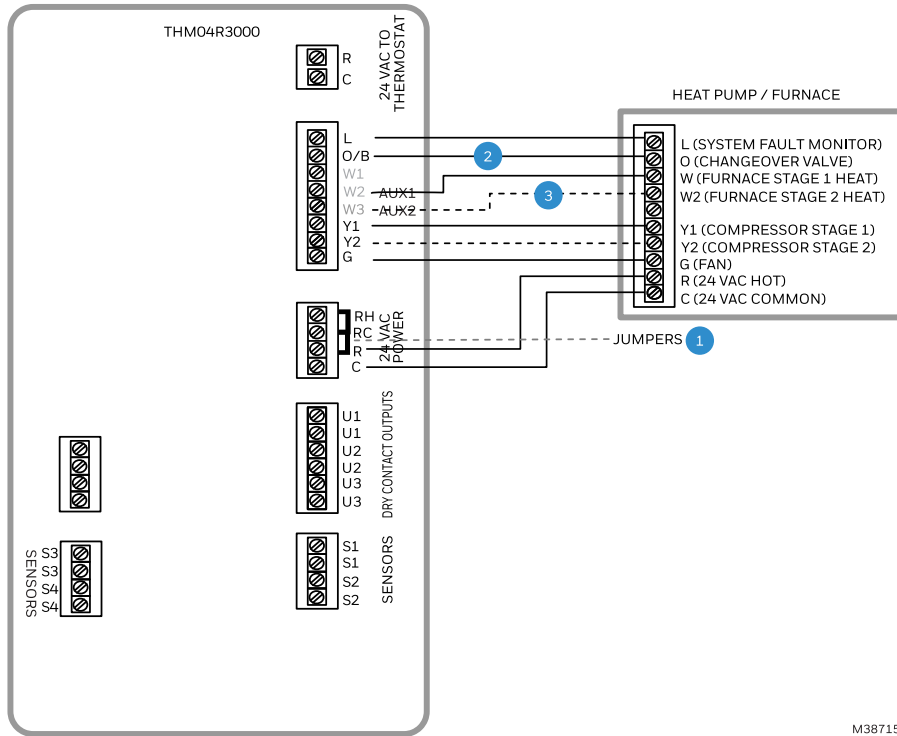

M38715A

- 1 Remove jumper(s) if using separate transformers.
- 2 The changeover valve will be labeled O if energized in cool or B if energized in heat.
- 3 The Heat Pump and Furnace have separate boards, they are shown together here to simplify this diagram.

NOTE: See following pages for additional thermostat wiring guidelines for other system types, sensor wiring, IAQ Control, and other dry contact wiring options.

Figure 45: Typical wiring of a heat pump system with boiler backup

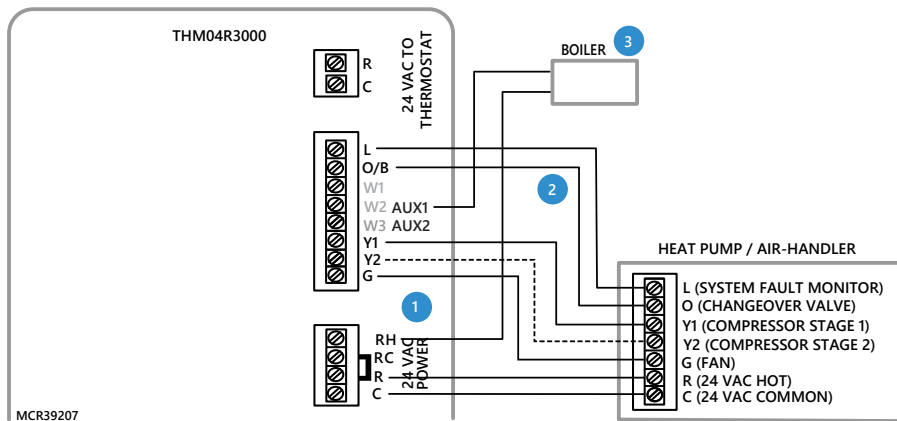

MCR39207

- 1 Remove jumper since the boiler has a separate transformer than the heat pump.
- 2 The changeover valve will be labeled O if energized in cool or B if energized in heat.
- 3 If using a hot water relay panel, the wires shown going to the boiler would instead wire to R and W on one of the zones of the panel.

NOTE: See following pages for additional thermostat wiring guidelines for other system types, sensor wiring, IAQ Control, and other dry contact wiring options.

Figure 46: Typical wiring of a heat pump system with a zone valve for Backup Heat

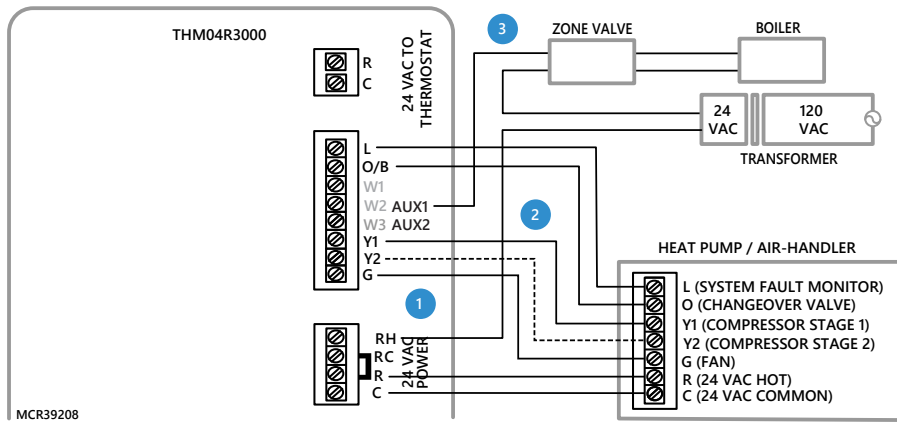

- 1 Remove jumper since the valve is powered by a separate transformer than the heat pump.
- 2 The changeover valve will be labeled O if energized in cool or B if energized in heat.
- 3 The wires that power the valve are shown on the left side of the valve. The end-switch wires from the valves go to the boiler.

NOTE: See following pages for additional thermostat wiring guidelines for other system types, sensor wiring, IAQ Control, and other dry contact wiring options.

Figure 47: Typical wiring of a spring-closed, power-open zone valve with end-switch

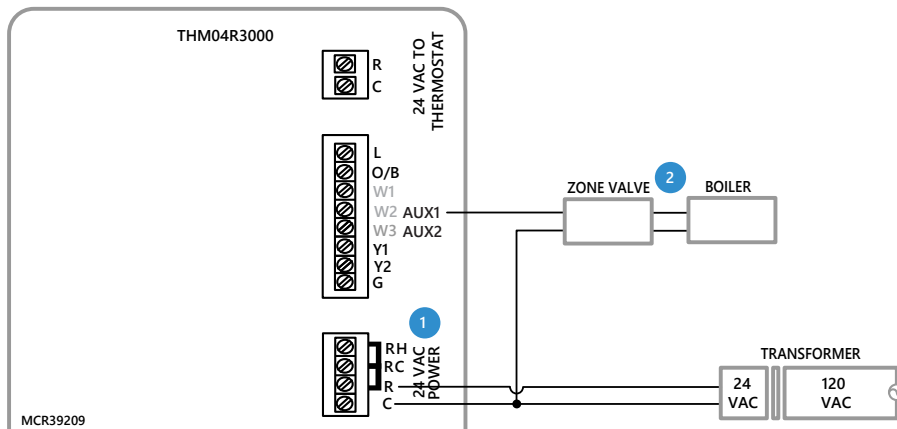

- 1 If also controlling cooling with a separate transformer, remove RH at EIM. Valve transformer C would not wire to EIM. Cooling transformer wire to R and C with R to RC jumper installed.
- 2 The wires that power the valve are shown on the left side of the valve. The end-switch wires from the valves go to the boiler.
- 3 If using an AC112-01 or equivalent slab sensor, wire that to any of the 4 sets of S terminals on EIM and make sure the ISU Settings match the wiring.

Figure 48: Typical wiring of a series 20, power-open/power-closed zone valve

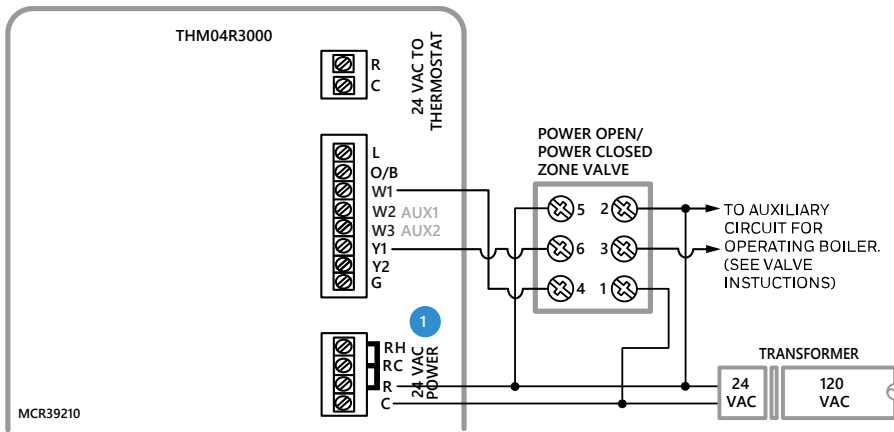

- 1 If also controlling cooling with a separate transformer, remove RH Jumper wire the valve transformer to RH at EIM. Valve transformer C would not wire to EIM. Cooling transformer wire to R and C with R to RC jumper installed.
 - 2 If using an AC112-01 or equivalent slab sensor, wire that to any of the 4 sets of S terminals on EIM and make sure the ISU Settings match the wiring.
- NOTE:** See following pages for additional thermostat wiring guidelines for other system types, sensor wiring, IAQ Control, and other dry contact wiring options.

Fan Coil Unit Wiring Diagrams with EIM

Figure 49: Typical wiring of 4-pipe fan coil

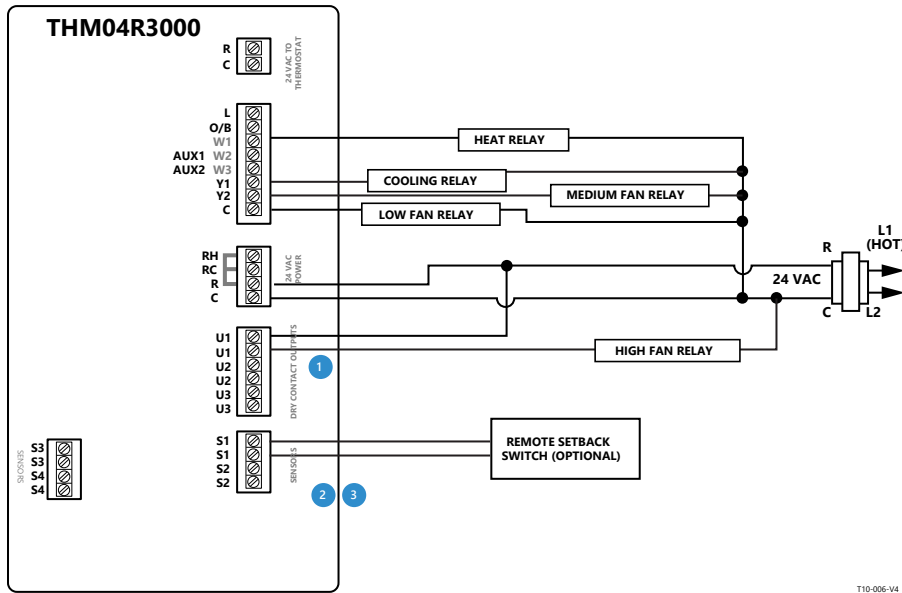

- 1 Any set of U contacts can be set to control high speed fan. One of those U contacts must be jumped to the fan coil transformer R as shown.
- 2 S terminals can be used for a wired indoor sensor or outdoor sensor.
- 3 If a remote setback switch is used, that switch wires to any set of S terminals at the EIM. Configure ISU settings 2240, 6010, 6020, 6030, & 6040 on the T10+ for remote setback.

Figure 50: Typical wiring of 2-pipe fan coil with reheat using wired 10K/20K Heat/Cool changeover pipe sensor

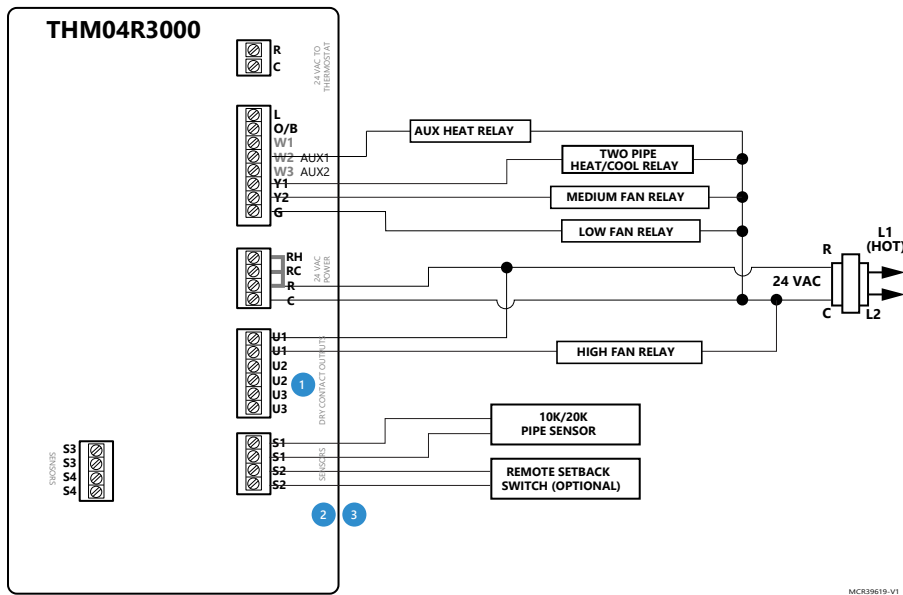

- 1 Any set of U contacts can be set to control high speed fan. One of those U contacts must be jumped to the fan coil transformer R as shown.
- 2 S terminals can be used for a 10K or 20K pipe sensor for Heat/Cool changeover.
- 3 If a remote setback switch is used, that switch wires to any set of S terminals at the EIM. Configure ISU settings 2240, 6010, 6020, 6030, & 6040 on the T10+ for remote setback.

Figure 51: Typical wiring of 2-pipe fan coil without reheat using wired 10K/20K Heat/Cool changeover pipe sensor

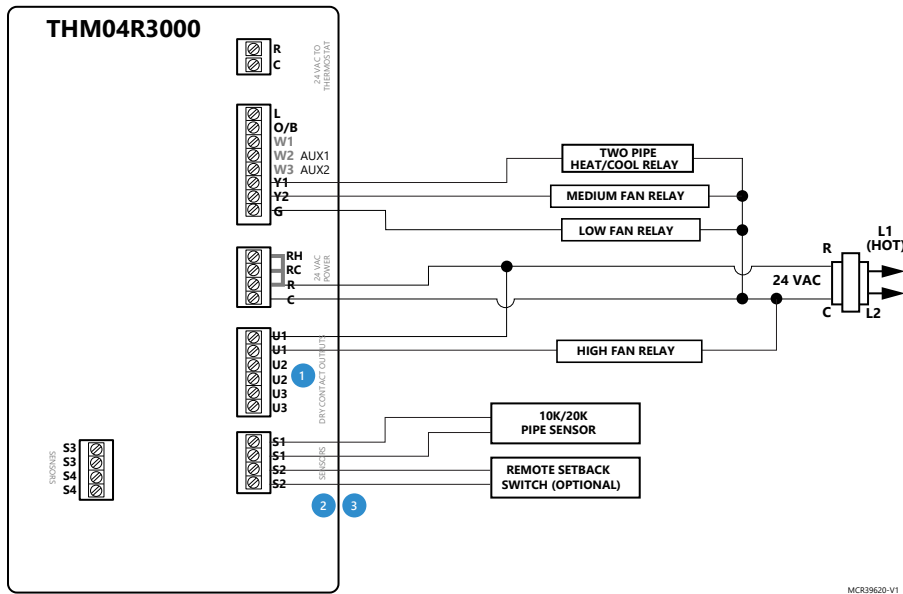

- 1 Any set of U contacts can be set to control high speed fan. One of those U contacts must be jumped to the fan coil transformer R as shown.
- 2 S terminals can be used for a 10K or 20K pipe sensor for Heat/Cool changeover.
- 3 If a remote setback switch is used, that switch wires to any set of S terminals at the EIM. Configure ISU settings 2240, 6010, 6020, 6030, & 6040 on the T10+ for remote setback.

Figure 52: Typical wiring of 2 pipe fan coil with reheat using dry contact switch for heat/cool changeover

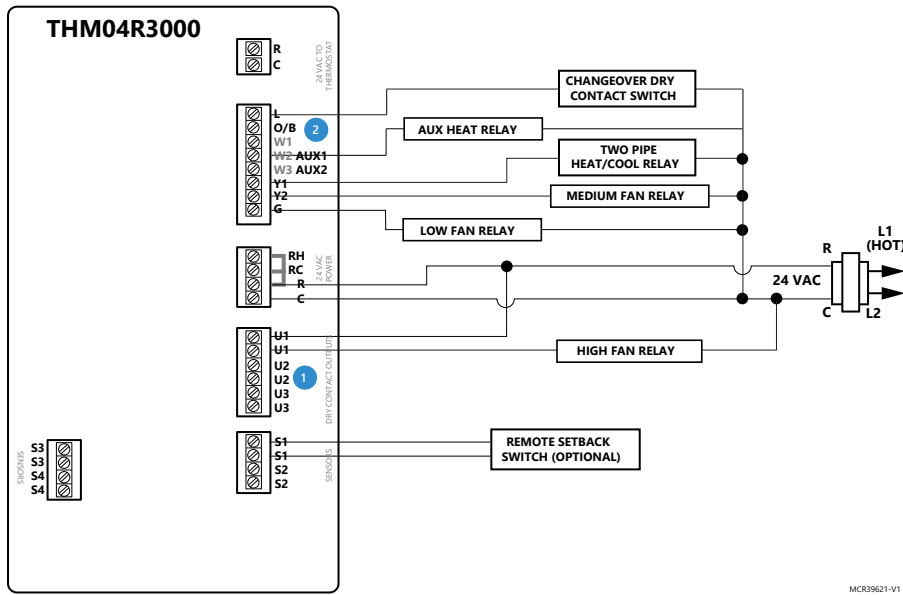

- 1 Any set of U contacts can be set to control high speed fan. One of those U contacts must be jumped to the fan coil transformer R as shown.
- 2 Wire the dry contact changeover switch to R at the fan coil unit and L at EIM as shown. T10+ can be configured for the changeover switch to be normally open in Cool or Heat mode.

Figure 53: Typical wiring of 2 pipe fan coil without reheat using dry contact switch for Heat/Cool changeover

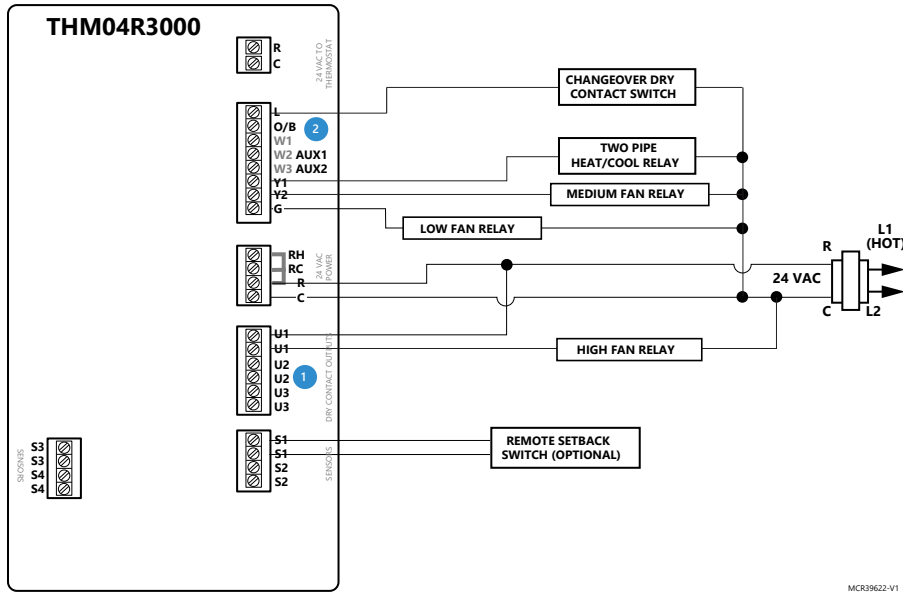

- 1 Any set of U contacts can be set to control high speed fan. One of those U contacts must be jumped to the fan coil transformer R as shown.
- 2 Wire the dry contact changeover switch to R at the fan coil unit and L at EIM as shown. T10+ can be configured for the changeover switch to be normally open in Cool or Heat mode.

Figure 54: Typical wiring EIM to a hot water relay panel

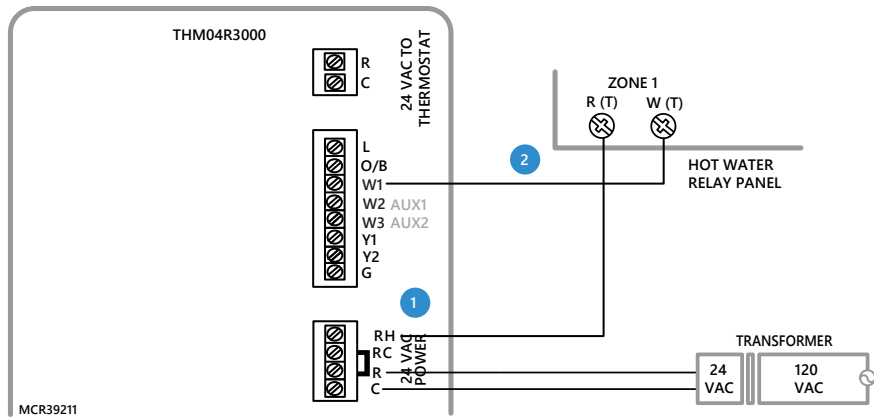

- 1 RH jumper removed. EIM powered by separate transformer.
- 2 If using an AC112-01 or equivalent slab sensor for the zone controlled by the thermostat, wire that to any of the 4 sets of S terminals on EIM and make sure the ISU settings match the wiring.

Figure 55: Typical wiring EIM to a Resideo TrueZONE forced air zone panel for conventional heat

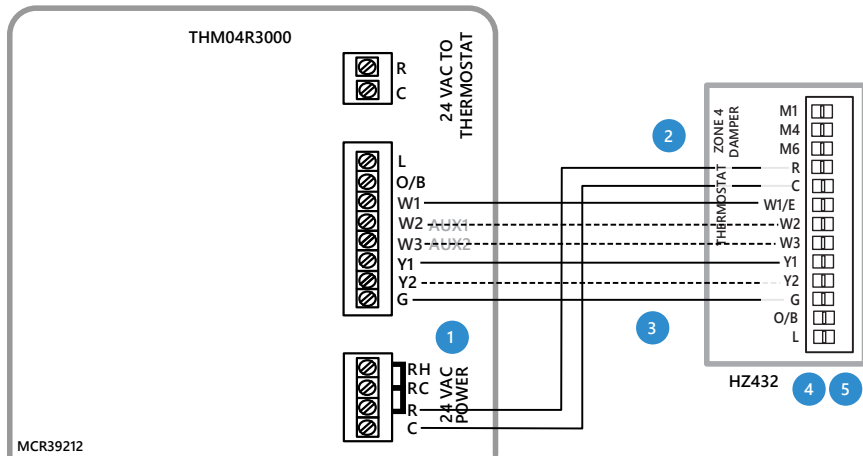

- 1 R to Rc jumper removed if EIM is powered by a separate transformer.
- 2 Zone 4 is shown in this drawing. The EIM can wire to any zone on the TrueZONE panel.
- 3 Dotted lines for Multistage only.
- 4 Wire the dampers, transformer and HVAC to zone panel as shown in zone panel installation guide.
- 5 It is not recommended to use a discharge sensor with the EIM on a zoned system. A discharge sensor can be wired to the zone panel for High and Low limit temperature protection.

Figure 56: Typical wiring EIM to a Resideo TrueZONE forced air zone panel for heat pump with electric Aux Heat application

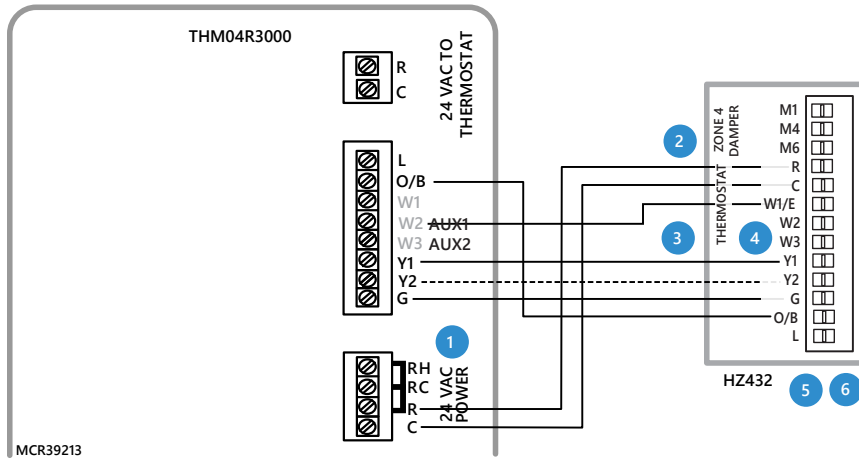

- 1 R to Rc jumper removed if EIM is powered by a separate transformer.
- 2 Zone 4 is shown in this drawing. The EIM can wire to any zone on the TrueZONE panel.
- 3 Y2 is for 2 stage compressor only.
- 4 Add a jumper from W1/E to W3 at zone panel if Y2 is used. Add a jumper at zone panel from W1/E to W2 if Y2 is not used.
- 5 Wire the dampers, transformer and HVAC to zone panel as shown in zone panel installation guide.
- 6 It is not recommended to use a discharge sensor with the EIM on a zoned system. A discharge sensor can be wired to the zone panel for High and Low limit temperature protection.

Figure 57: Typical wiring EIM to a Resideo TrueZONE forced air zone panel for dual fuel heat pump application

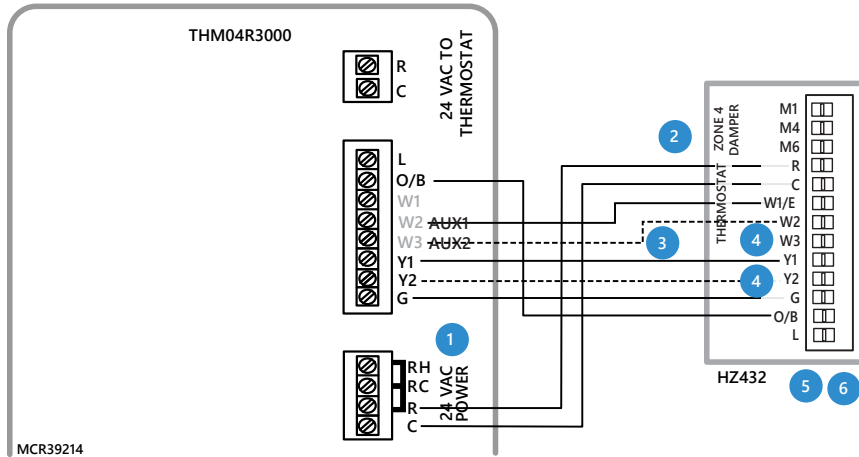

- 1 R to Rc jumper removed if EIM is powered by a separate transformer.
- 2 Zone 4 is shown in this drawing. The EIM can wire to any zone on the TrueZONE panel.
- 3 W2 is for 2 stage furnace only.
- 4 Y2 is for 2 stage compressor only.
- 5 Wire the dampers, transformer and HVAC to zone panel as shown in zone panel installation guide.
- 6 It is not recommended to use a discharge sensor with the EIM on a zoned system. A discharge sensor can be wired to the zone panel for High and Low limit temperature protection.

Wiring Dry Contact Alerts with EIM

Figure 58: Dry contact alerts

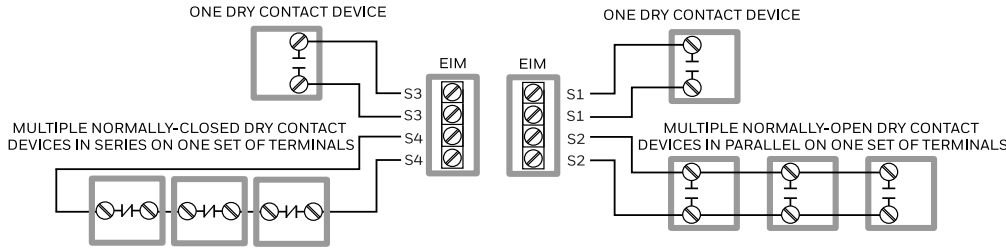

M39654

Figure 59: U terminals can be used for humidification, dehumidification or ventilation

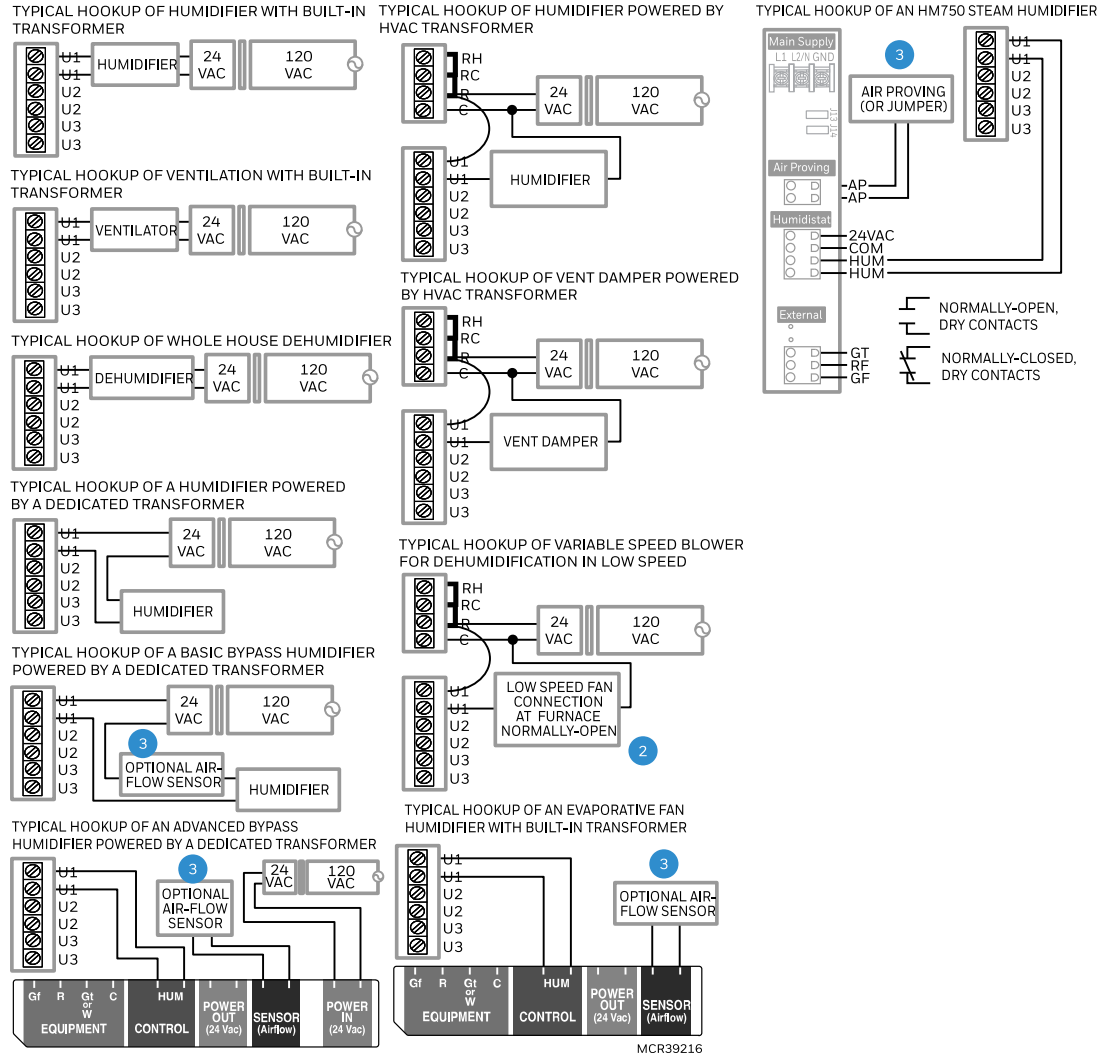

MCR39216

- 1 Any combination of relays (U1, U2, U3) can be used. They are set in the thermostat Installer Setup.
- 2 Wire the U relay to the low speed fan for dehumidification control at the equipment. The EIM relay can be set to normally open or normally closed in the thermostat Installer Setup.
- 3 An optional 50027910-001 Air-Flow switch (AFS) is recommended to ensure air flow when the humidifier is running. If the AFS is used, set dip switch 1 to Off (Left). The T10+ can be configured to only run the humidifier with a call for heat or fan, so the AFS would only be needed to ensure no water flow through the humidifier pad if there is a fan failure. The T10+ can alternately be configured for a fan failure alert (ISU 6000, 6150 and 6160).

Linking the T10+ to an Optional EIM

1. When the T10+ is powered, follow the onscreen prompts until you see **Do you have an Equipment Interface Module (EIM)?**

Select **Yes, I have an EIM**.



2. Press and release the **CONNECT** button at the EIM when the thermostat prompts you. Make sure the “Connected” lights is flashing green. The EIM will continue to flash the connected light for 15 minutes and reset this timer every time a new RedLINK 3.0 device is added.

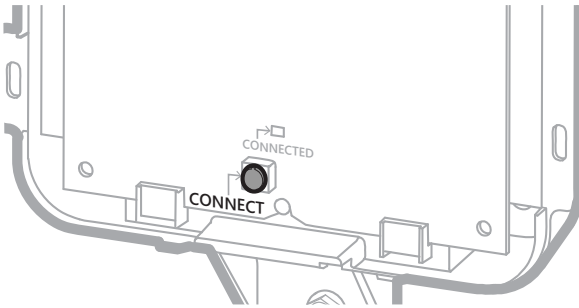

M34176A

Figure 60: EIM Connect Button

NOTE: If the **CONNECTED** light does NOT flash green, another system may be in **Listening Mode**. Please exit Listening Mode on the other system and try again.

- Green Flashing: In Listening Mode. System is ready to add RedLINK 3.0 devices.
- Green Steady: RedLINK 3.0 devices are communicating.
- Red: RedLINK 3.0 device(s) are not communicating. Check EIM and RedLINK devices.

3. Return to the thermostat and press **Next** (shown in the left image below).

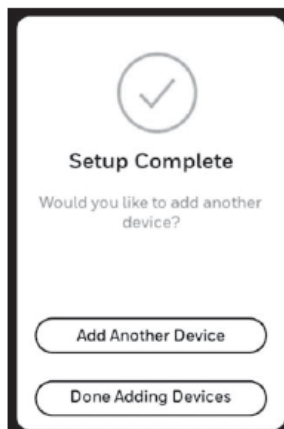
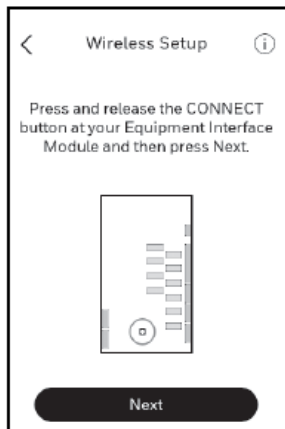

4. Adding RedLINK 3.0 Accessories to the T10 or T10+ Thermostat.

NOTE: The EIM and wireless outdoor sensor can only be connected to a T10+. The T10 installation will skip the EIM section and go directly to the wireless indoor sensor during initial setup.

5. Select **Add Another Device** and follow the prompts on screen.

6. Install batteries in RedLINK 3.0 accessories.

- Wireless Outdoor Sensor RedLINK 3.0 C7089R3013 (T10+ only).
- Wireless Indoor Sensor (C7189R3002 or C7189R2002)

7. Connect each RedLINK 3.0 accessory.

NOTE: Make sure RedLINK 3.0 accessories are at least 2 feet away from the thermostat (or EIM, if used) during the linking process.

8. While the “Connect Device” screen is displayed (Listening Mode), press and quickly release the **CONNECT** button on each new RedLINK 3.0 accessory.

9. After a short delay (up to 20 seconds), check the thermostat to confirm the connection of each RedLINK 3.0 accessory.

NOTE: If adding a wireless indoor sensor or wireless outdoor sensor (outdoor on T10+ only) after the initial setup has been completed, go to Menu > Installer Options > Devices and Sensors, and select **Add**.

10. Follow the instructions on thermostat screen. After each RedLINK 3.0 accessory is added and any follow up questions are set, the thermostat will ask if you want to add another device or are done adding devices.

NOTE: Examples of follow up questions and instructions for the wireless indoor sensor shown below.

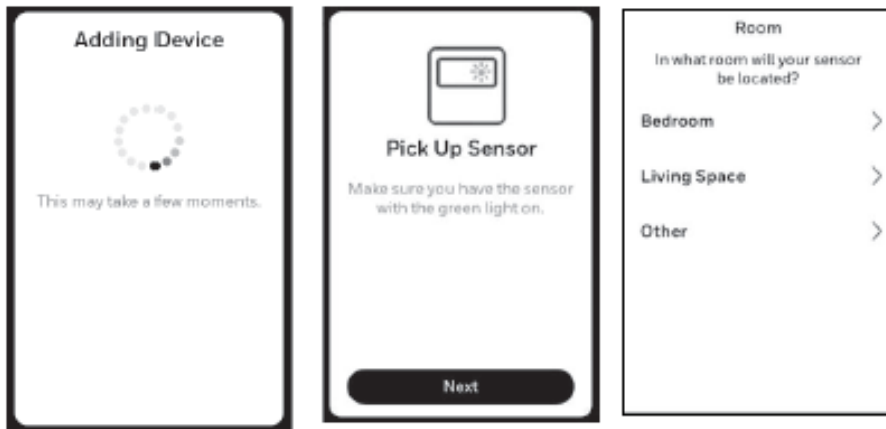

11. Once all RedLINK 3.0 accessories have been added and you have completed the on-screen follow-up questions and instructions, the display will say “Setup Complete”. Select **Done Adding Devices**.

12. Follow the onscreen display instructions to complete system setup for heating and cooling type, humidifier, dehumidifier, ventilator settings, etc.

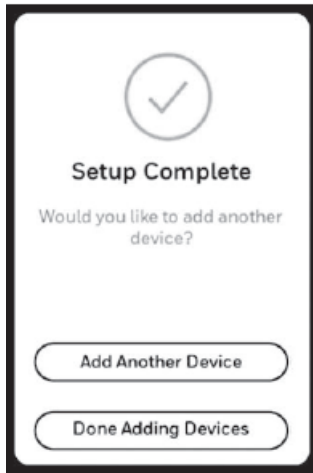

To Replace the Equipment Interface Module (EIM)

When you replace an EIM, you must reset the RedLINK 3.0 accessories before connecting them to the new thermostat. Follow the instructions below:

At the Indoor Sensor or other RedLINK 3.0 accessory:

Press and hold the **CONNECT** button on the accessory until the status light glows amber (hold for about 10 seconds). To reconnect the thermostat, go to Step 4.

At the thermostat:

Go to **Installer Options**, choose **Reset**, then **Factory reset**. This will clear the EIM and any other RedLINK 3.0 devices from T10+ as well as the system settings. After doing Factory Reset, follow thermostat prompts to link new EIM and configure system settings.

To replace a T10+ connected to an EIM

Press and hold the connect button on the EIM until the connect light turns amber approximately 10 seconds. This should clear the EIM from the thermostat and any RedLINK 3.0 accessories. Then it is ready to be connected to a new T10+ thermostat using the original setup process.

NOTE: The new T10+ will also guide you through the setup steps during initial setup when you choose that you have an EIM.

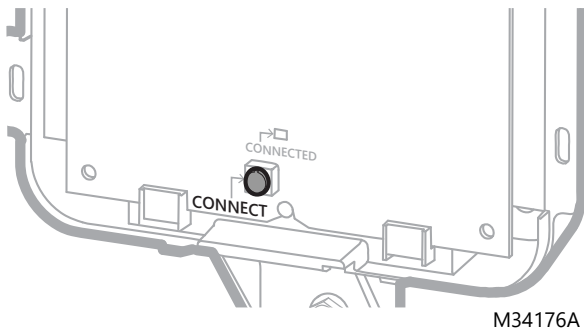

Figure 61: EIM Connect Button

SENSOR INSTALLATION

Wireless Indoor Sensor Installation

C7189R2002 or C7189R3002 Wireless Indoor Sensor

1. Remove white cover from gray base and Insert (2) AAA Alkaline batteries in the sensor.

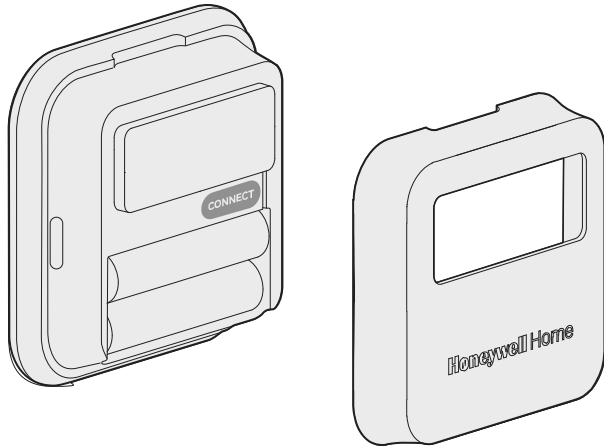
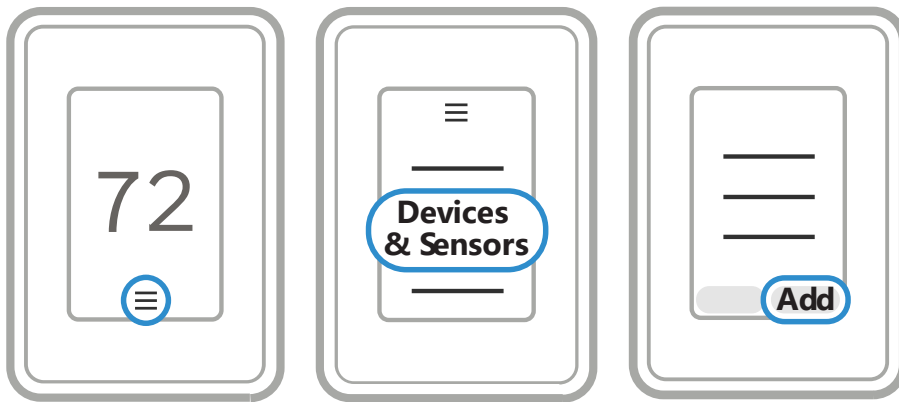

Figure 62: Sensor cover removal

2. Open the **Menu**.
3. Tap **Devices & Sensors**.
4. Tap **Add**.

Follow the on-screen instructions.



M39060

5. Snap the sensor onto the wall-plate.
6. Adhere the included command strip to the wall-plate. Then adhere the sensor to the wall. Level sensor for appearance. (See the sensor instructions for proper placement.)

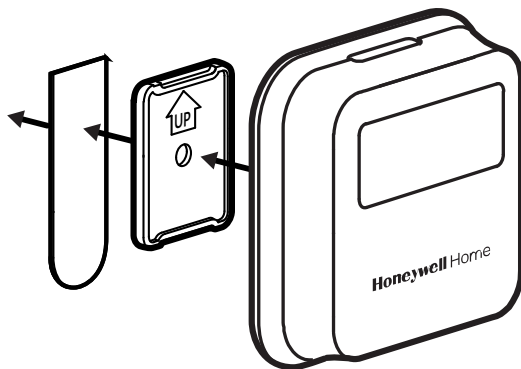

M39058

Figure 63: Sensor mounting

Placement Tips

- DO place about 5 feet above the floor.
- DO place on inside walls.
- DON'T place behind furniture or doors.
- DON'T place in direct sunlight.
- DON'T place above air vents.

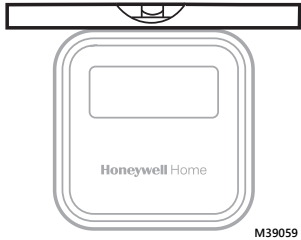

Figure 64: Sensor leveling

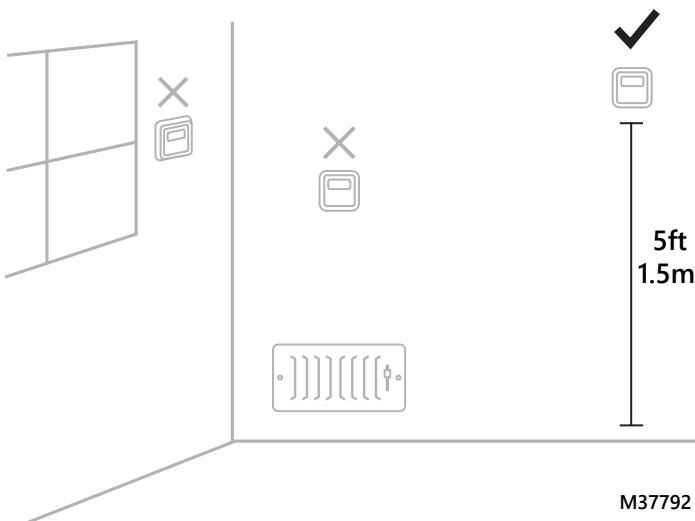

Figure 65: Sensor Placement

These sensors can be linked to the thermostat when doing the initial Installer setup or at a later date.

- During initial installer setup, the thermostat will offer setup options under “RedLINK Devices” for “Add device” or “Set up later”.
- To add a sensor after initial setup has been done, select the **Menu** icon, then **Devices & Sensors**, then **Add**.
 - The display screen will walk you through linking and naming the sensor.

Wireless Outdoor Sensor Installation

C7089R3013 Wireless Outdoor Sensor (T10+ Only)

The C7089R3013 wireless outdoor temperature & humidity sensor can be used with up to eight T10+ thermostats for heat pump compressor lockouts, Aux Heat lockouts, humidity frost control, and ventilation lockouts. Alternately, Internet weather could be used for these lockouts. A wired outdoor sensor can be used for all outdoor lockouts other than High Dewpoint Lockout for ventilation.

Connecting Wireless Outdoor Sensor

When the T10+ thermostat is in the wireless setup mode and prompts you to do so, press and quickly release the **CONNECT** button on the Wireless Outdoor Sensor. After a short delay (up to 15 seconds), the thermostat will display "Wireless Outdoor Sensor Added."

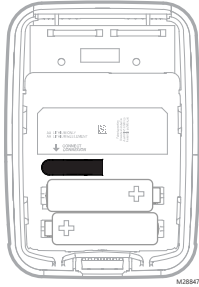

Figure 66: Wireless outdoor sensor connect button

Mount Outdoor Sensor

1. Mount the sensor on a vertical exterior wall, at least 6 inches below any overhang. Choose a location protected from direct sunlight.

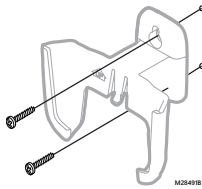

Figure 67: Mounting outdoor sensor

2. Place sensor securely in bracket, facing away.

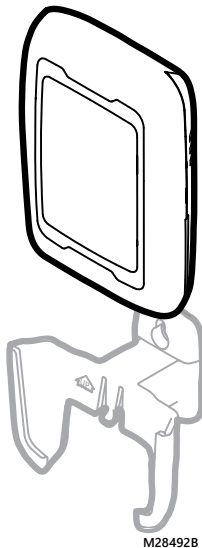

Figure 68: Mounting outdoor sensor 2

Selecting Return Air Temperature Sensor Mounting Location

NOTE: When the return sensor is used with T10+ & EIM, If there's a communication loss with the thermostat, the backup algorithm will turn on heating stages if the return air temperature is $< 56.0^{\circ}\text{F}$ and run until the return air temperature reaches 58°F .

NOTE: The backup algorithm will turn on cooling stages if the return air temperature is $> 88.0^{\circ}\text{F}$ and run until the return air temperature reaches 86° .

Install the Return Air Temperature Sensor on the return duct in a location where the air is mixed well. Mount the Return Air Temperature Sensor downstream of a Bypass Humidifier, Dehumidifier or Ventilator.

Selecting Discharge Air Temperature Sensor Mounting Location

1. Mount the Discharge Air Temperature Sensor on the supply duct in a location where the air is mixed well. Mount the Discharge Air Temperature Sensor out of sight of the A-Coil/Heat Exchanger when possible.
2. When possible, mount the Discharge Air Temperature Sensor upstream of a Steam Humidifier, a Fan Powered Humidifier or a Dehumidifier that is ducted to the supply.
3. Resideo does not recommend wiring a discharge sensor to the EIM in a zoned system. A discharge air sensor can be wired to a Resideo TrueZONE panel and the panel will do the high/low limit protection for the system.
4. If space does not allow a Discharge Air Temperature Sensor upstream of a Steam Humidifier or Fan Powered Humidifier, mount the Discharge Air Temperature Sensor downstream of the Humidifier.

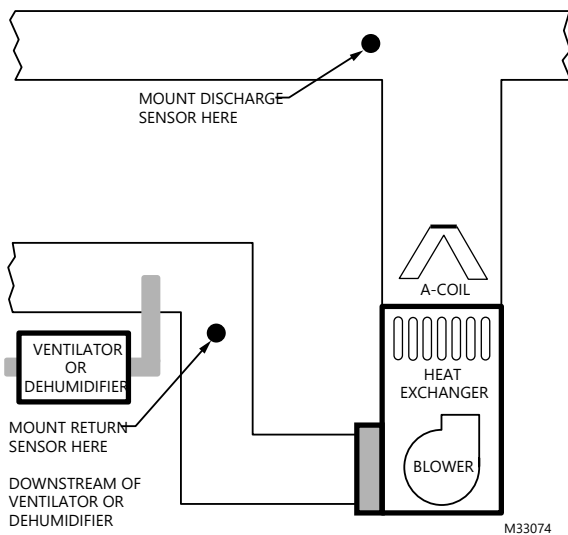

Figure 69: Discharge Sensor Location 1

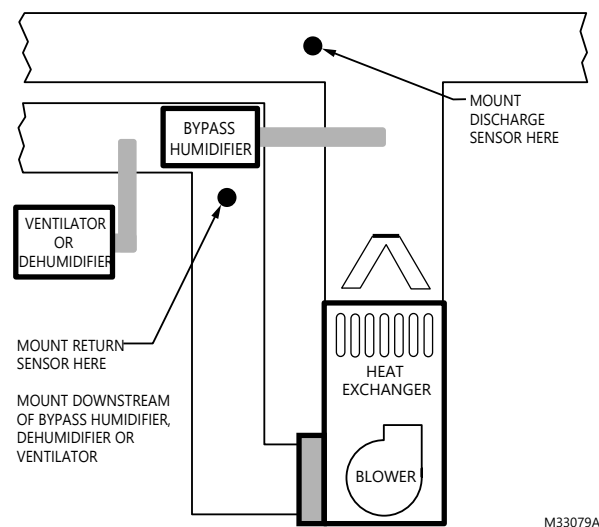

Figure 70: Discharge Sensor Location 2

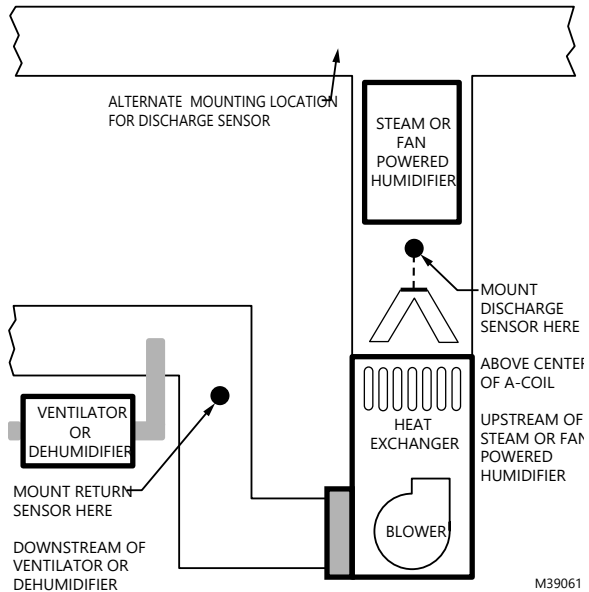

Figure 71: Discharge Sensor Location 3

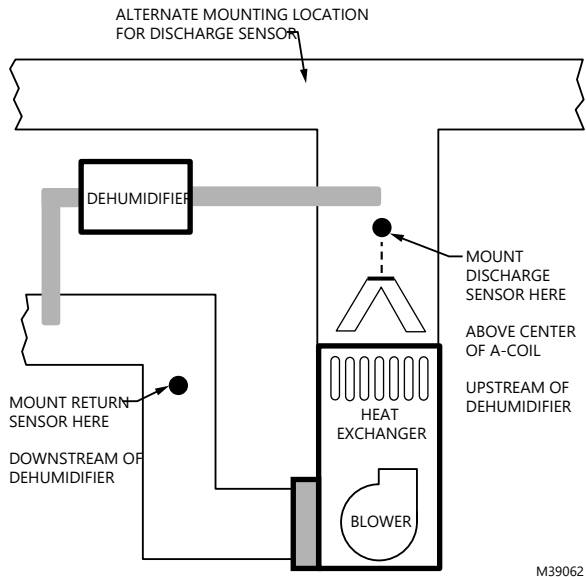

Figure 72: Discharge Sensor Location 4

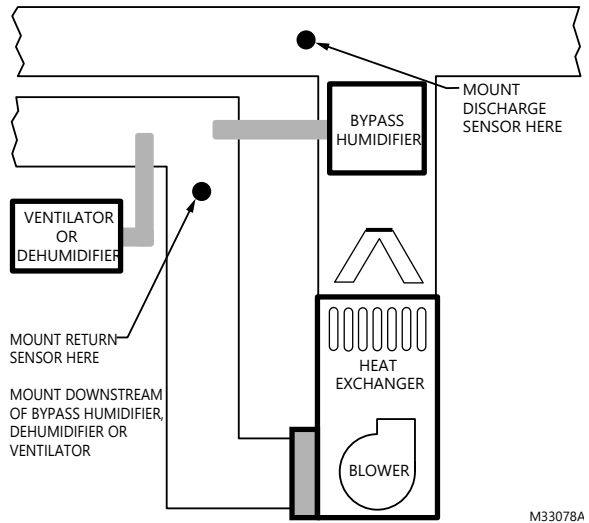

Figure 73: Discharge Sensor Location 5

Installing Discharge and/or Return Air Temperature Sensors (T10+ only)

Use the following steps to mount the Discharge/Return Air Sensors:

1. Attach plastic cover to the sensor probe.
2. Drill 1/4-inch hole for the sensor probe and mount it to the ductwork with enclosed screws.
3. Connect wires to S1, S2, S3, or S4 terminals at the EIM or S terminals at T10+ when EIM is not used.
4. Configure the T10+ thermostat for discharge and/or return sensor.

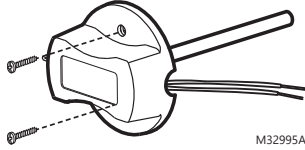

Figure 74: Mounting Discharge/Return Air Sensor.

Installing Wired Indoor Sensor

C7189U1005 (10K) Wired Indoor Sensor

ISU setting 5000.

Use the following steps to mount the sensor:

1. Remove the cover from the remote sensor.

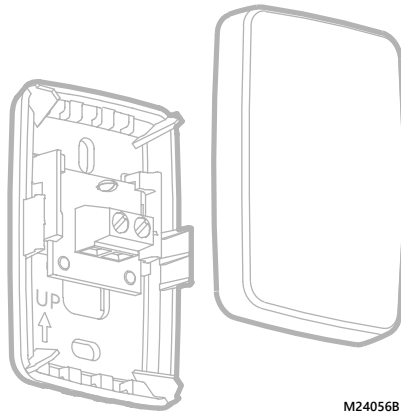

Figure 75: Remove the cover.

2. Pull wires through wire hole.
3. Position wallplate on wall, level and mark screw hole positions with pencil.
4. Drill holes at marked positions, then tap in supplied wall anchors.
5. Place wall plate over anchors, insert and tighten mounting screws see image below.

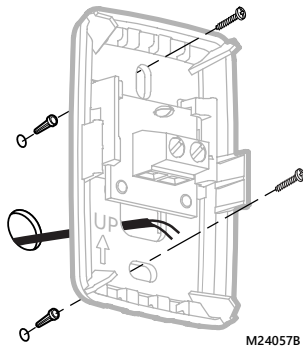

Figure 76: Mount wall plate to wall.

6. Replace the cover on the remote sensor.

**CAUTION: ELECTRICAL HAZARD**

Can cause electrical shock or equipment damage. Disconnect power supply before connecting wiring.

Wiring 1 C7189U1005 sensor (10k ohm) for temperature control. Select 10K in the Installer Setup (ISU 5030) when using C7189U1005 sensor(s).

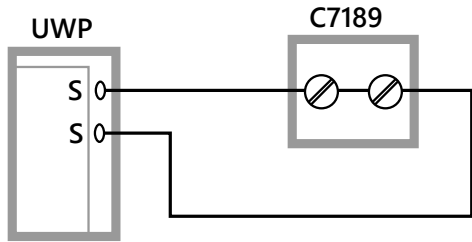

NOTE: IF EIM IS USED, WIRE TO ANY OF THE AVAILABLE SETS OF S (S1, S2, S3, S4)

M39063

Figure 77: Wiring 1 C7189 sensor.

Wiring 4 C7189U1005 sensors (10k ohm) for temperature averaging network. Select 10K in the Installer Setup (ISU 5030) when using C7189U1005 sensor(s).

If EIM is used, wire to any of the available sets of S (S1, S2, S3, S4).

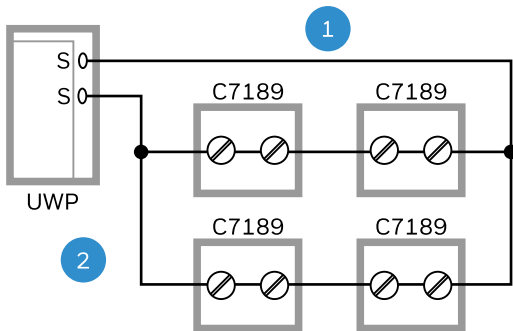

1 THE NUMBER OF C7189U SENSORS MUST BE A SQUARE NUMBER (1, 4, 9, 16, ETC.)

2 IF EIM IS USED, WIRE TO ANY OF THE AVAILABLE SETS OF S (S1, S2, S3, S4)

M39064

Figure 78: Wiring 4 C7189U sensors

NOTE: If EIM is used, wire to any of the available sets of S (S1, S2, S3, S4).

Installing Wired Outdoor Sensor

See ISU 1060 "Outdoor Temperature" for correct thermostat configuration.

Follow instructions included with C7089U1006 wired outdoor sensor.

Location and Mounting

Mount the sensor where:

- there is good air circulation.
- it can measure true outdoor ambient temperature.
- surface is flat.
- wire distance between C7089U and thermostat is less than 200 feet.

Do not mount the sensor:

- In direct sunlight.
- Where hot or cold air blows on the sensor. Discharge line from an outdoor compressor unit, vent or fan causes inaccurate temperature readings.
- Where snow, ice or debris can cover it.

Use the following steps to mount the sensor:

1. Remove the sensor from the mounting clip.
2. Mark the area on the location selected for mounting the sensor mounting clip.
3. Mount the clip.

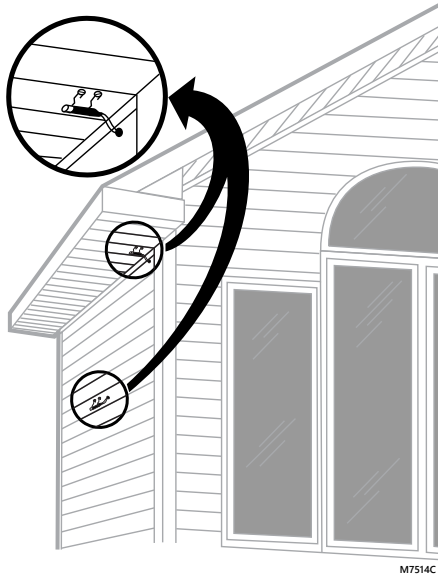

Figure 79: Outdoor sensor mounting clip installation



CAUTION: Electrical Interference (Noise) Hazard.

Can cause erratic system operation. Keep wiring at least one foot away from large inductive loads such as motors, line starters, lighting ballasts and large power distribution panels. Use shielded cable to reduce interference when rerouting is not possible.

Floor/Slab Sensor (T10+ only)

The T10+ Smart Thermostat can be used with a floor/slab sensor to control the ambient air temperature or floor temperature or both. You can choose among the following temperature control modes.

A mode: Controls and displays the ambient air temperature only.

- F mode: Controls and displays the floor temperature only using an external floor temperature sensor. This control mode is suitable for areas such as bathrooms where floor temperature could be scheduled to be warm only during occupied, morning and evening periods.
- Floor temperature is indicated by “FLR” above the actual floor temperature.
- Actual ambient air temperature could also be displayed in the Thermostat MENU/TEMP. AF mode: Controls and displays the ambient air temperature as well as maintains the floor temperature within desired floor temperature limits using an external floor temperature sensor. Setting the minimum and maximum floor temperature limits is a way to enhance comfort and to protect the floor covering at the same time.
- Actual floor temperature could also be displayed in the Thermostat MENU/ TEMPERATURES.

NOTE: To set the thermostat temperature control mode, go to **"Installer Setup Options (ISU)"** on page 53 and see settings (1055 & 5120-5170).

Floor/slab sensor wiring shown on following page.

Floor Temperature Sensor Installation

T10+ Thermostat is compatible with the following 10K ohm floor temperature sensors: AC112-01.

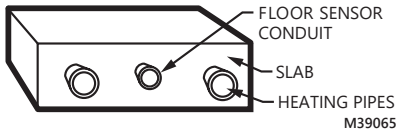

Figure 80: Floor sensor conduit position in a slab

The floor temperature sensor needs to be installed mid way between the piping to ensure proper temperature reading (not over or right next to piping). Example: For a 12" pipe spacing install the sensor 6" away from the piping and ensure the sensor is vertically centered.

We recommend installing the floor temperature sensor inside of min. 0.5" PEX pipe. This simplifies future sensor replacement, if required.

In a small room, position the sensor in the center of the floor. In larger rooms, ensure the sensor is at least 7 feet from the wall.

Recommended Floor Temperatures Settings

Recommended maximum floor temperature is 90 °F (32 °C) for most floor covering types except wood. Suggested maximum floor temperature for wood floor is 85 °F (29.5 °C). Freeze protection temperature for garages and basements is suggested to be set between 41 °F - 45 °F (5 °C - 7.2 °C).

See ISU settings (1055, 3250, and 5120-5170)

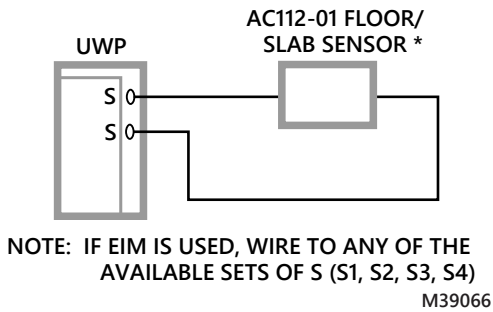

Figure 81: Floor sensor and UWP installation

Wire the floor/slab sensor to the S terminals on the UWP if EIM is not used. If EIM is used, wire floor/slab sensor to any of the sets of S terminals. Make sure the floor/slab sensor settings match the wiring. See ISU settings (1055, 3250, and 5120-5170).

* A 10K ohm TekMar slab sensor could be used in place of the AC112 01 Floor sensor

Important

Erratic temperature readings from a sensor can occur as a result of any of the wiring practices described below. Avoid these practices to assure correct operation. Use shielded cable to reduce interference if rerouting of sensor wiring is not possible.

- Be sure wires have a cable separate from the thermostat cable.
- Do not route temperature sensor wiring with building power wiring, next to control contacts or near light dimming circuits, electric motors or welding equipment.
- Avoid poor wiring connections.
- Avoid intermittent or missing building earth ground.

OR

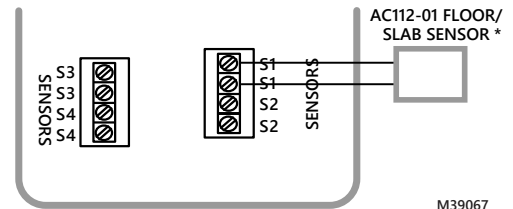

Figure 82: Floor sensor and EIM installation

INSTALLER SETUP (ISU)

New Installation

1. After the thermostat has powered up, touch **GET STARTED** on the thermostat.
2. After selecting the correct option for each setting, Touch **NEXT** at the bottom of the display to advance to the next option.
3. To see a list of all setup parameters, go to "**Installer Setup Options (ISU)**" below. The thermostat displays the ISU name.
4. To finish setup and save your settings, touch **Done** in the upper left of display.

Revising Settings

If this is not a new installation and you want to access the Installer setup to change settings:

1. Touch the **Menu** icon (3 horizontal lines at bottom of display).
2. Scroll down and touch **Thermostat Information**.
3. Write down the date code from that screen. The touch the left arrow at top of display to go to previous screen.
4. Scroll down until **Installer Options** is shown. Touch **Installer Options** and enter date code.
5. Select **Installer Setup**.
6. After selecting the correct option for each setting, Touch **NEXT** at the bottom of the display to advance to the next option.
7. To see a list of all setup parameters, go to "**Installer Setup Options (ISU)**" below.
8. To finish setup and save your settings, touch **Done** in the upper left of display.

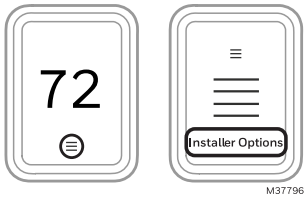

M37796

Installer Setup Options (ISU)

NOTE: Firmware is occasionally updated at the factory or over the air. Some ISU settings may not be shown on models that lack the latest firmware. Light commercial and fan coil unit settings available on T10+ with firmware 03.03.08.02 or later)

ISU #	Heading	Question	Options	Contingent previous setting?	EIM needed?	T10, T10+ or both	Notes
1000	Language	What language would you like to use?	<ul style="list-style-type: none"> • English • Francais • Espanol 		No	Both	ISU number not displayed during initial setup
1010	Application	What type of installation will this thermostat be used for?	<ul style="list-style-type: none"> • Residential • Commercial 		No	T10+	Available on T10+ & EIM with latest firmware
None shown	Room	In what type of room will this thermostat be installed?	<ul style="list-style-type: none"> • Bedroom • Living space • Area • Unit name or Other 	Options shown vary for Residential or light commercial	No	Both (light commercial for T10+ only)	Only shown during initial setup
1030	Home Screen	Would you like the device name displayed on the home screen?	<ul style="list-style-type: none"> • No • Yes 	1010 = light commercial	No	T10+	
1050	Units	Which temperature scale would you like to use?	<ul style="list-style-type: none"> • Fahrenheit • Celsius 		No	Both	

ISU #	Heading	Question	Options	Contingent previous setting?	EIM needed?	T10, T10+ or both	Notes
No ISU number	Equipment Interface Module	Do you have an Equipment Interface Module (EIM)?	<ul style="list-style-type: none"> • Yes, I have an EIM • No 			T10+	Only shown during initial setup
No ISU number	Wireless setup	Press and release CONNECT button on the Equipment Interface module (EIM). When the Connect light is flashing green on the EIM, then press Next.	NEXT		Yes	T10+	Only shown during initial setup
1055	Floor sensor	Floor sensor	<ul style="list-style-type: none"> • No or • Wired 		No	T10+	
1060	Outdoor Temperature	Outdoor Temperature	<ul style="list-style-type: none"> • None • Wired • Wireless* • Internet <p>(*Wireless automatically selected if sensor added during setup)</p>	Wireless only shown if C7089R3013 has been linked to T10+ during setup.	No	See notes	*T10 & T10+ have this setting but wireless outdoor sensor only for T10+
2000	System Type	System Type	<ul style="list-style-type: none"> • Conventional Forced Air Heat • Heat Pump • Radiant Heat • Fan Coil* • Other • None (Cool only) 		No	Both	*Fan coil option only shown here for T10+ with latest firmware. For older firmware and T10 models: If you select Conventional Forced Air here, you will get the option for Hot Water Fan Coil in 2010.
2010	Equipment type	Equipment type	<ul style="list-style-type: none"> • Standard Efficiency Gas Forced Air • High Efficiency Gas Forced Air • Oil Forced Air • Electric Forced Air • Hot Water Fan Coil* 	2000 = Conventional Forced Air Heat	No	Both	*If a T10+ with firmware 03.03.08.02 or later, there is a setting for Fan Coil under 2000 (row above). When selected, you will see options for Hot Water Fan Coil, 2-pipe, or 4-pipe in ISU 2010
		Equipment type	<ul style="list-style-type: none"> • Air to Air Heat Pump • Geothermal Heat Pump 	2000 set to Heat Pump	No	Both	
		Equipment type	<ul style="list-style-type: none"> • Gravity or • Other 	2000 = other	No	Both	
		Equipment type	<ul style="list-style-type: none"> • Hot water radiant heat • Hot water radiant floor heat* • Steam 	2000 set to Radiant Heat	No	Both*	*Hot water radiant floor heat for T10+ only
		Equipment type	<ul style="list-style-type: none"> • Hot water fan coil • 2-pipe • 4-pipe 	2000 = fan coil	No		2-pipe and 4-pipe for T10+ only. Added with Firmware 03.03.08.02 or later

ISU #	Heading	Question	Options	Contingent previous setting?	EIM needed?	T10, T10+ or both	Notes
2054	Fan coil	Changeover sensor	<ul style="list-style-type: none"> None Dry contact 10K 20K 	2010 = 2-pipe	No	T10+	Method for T10+ to determine if pipe is hot or cold. The 2-pipe FCU wiring diagrams show how this should be wired to the T10+ or EIM
2055	Fan coil	Changeover sensor setup	<ul style="list-style-type: none"> Dry contact open in Cool Dry contact open in Heat 	2054 = dry contact	No	T10+	
2056	Fan coil	Changeover wiring assignment	<ul style="list-style-type: none"> None Thermostat S1 EIM S1-S4 (If EIM is used, only EIM S1-S4 options are shown) 	2054 = 10K or 20K	No	T10+	
2060	Reversing Valve	Reversing Valve	<ul style="list-style-type: none"> 0 (O/B on Cool) or B (O/B on Heat) 	2000 set to Heat Pump	No	Both	
2070	Equipment stages	Cool stages	<ul style="list-style-type: none"> 0-2 stages if 1010 = Residential 0-4 if 1010 = Light Commercial 	2000 set to other than Heat Pump	EIM needed for 4 cool stages	Both	
		Heat stages	<ul style="list-style-type: none"> 1-2 if EIM is not used 1-3 if EIM is used. 		No	Both	
		Radiant Heat Stages	<ul style="list-style-type: none"> 1 if 1055 = Yes 1 or 2 if 1055 = No & 2000 = Radiant 	1055 set to Wired or 2000 = Radiant Heat	No	Both	
		Compressor Stages	<ul style="list-style-type: none"> 1 2 	2000 set to Heat Pump	No	Both	
		Fan Coil Heat Stages	<ul style="list-style-type: none"> 1 2 3 	2010 = Hot Water Fan Coil	See notes	Both	EIM needed for 3 stages
		Electric Forced Air Heat Stages	<ul style="list-style-type: none"> 1 2 3 	2010 = Electric Forced Air	See notes	Both	EIM needed for 3 stages.
		Fan coil stages	<ul style="list-style-type: none"> 1 	2000 = fan coil	No	T10+	
		Backup Heat Stages	<ul style="list-style-type: none"> 0 1 2* 	2000 set to Heat Pump or 2-Pipe Fan Coil	See notes	Both	*2 only shown for heat pump and using EIM
2080	Terminal assignment	What terminals are wired to cool stage 3?	<ul style="list-style-type: none"> U on UWP when EIM isn't used U1-U3 if EIM is used 	2070 = 3 or 4 Cool stages	No	T10+	See wiring diagrams for cool 3-4 wiring.
2090	Terminal assignment	What terminals are wired to cool stage 4?	<ul style="list-style-type: none"> U1-U3 if EIM is used. 	2070 = 4 Cool stages	Yes	T10+	

ISU #	Heading	Question	Options	Contingent previous setting?	EIM needed?	T10, T10+ or both	Notes
2105	Fan Control	Fan stages	<ul style="list-style-type: none"> 1 - 3 	2010 = 2-pipe or 4-pipe Fan Coil	No	T10+	During setup, T10+ instructs where to wire this to. There are also wiring diagrams in this file. * If only 2 fan speeds are used, ISU 2106 will say High Speed rather than Medium Speed
2106	Fan Coil	Medium * Fan Speed Wiring Assignment	<ul style="list-style-type: none"> None Y2 EIM Y2* 	2105 = 2 - 3	No	T10+	
2107	Fan Coil	High * Fan Speed Wiring Assignment	<ul style="list-style-type: none"> None Thermostat U1 EIM U1 EIM U2 EIM U3 	2105 = 3	No	T10+	
2110	Fan Control	Fan Operation in Heat	<ul style="list-style-type: none"> Equipment Controls fan Thermostat controls fan 	2010 = other, Electric Forced Air	No	Both	
2120	Backup heat type	Backup heat type	<ul style="list-style-type: none"> None Standard Efficiency Gas Forced Air High-Efficiency Gas Forced Air Oil Forced Air Electric Forced Air Hot Water Fan Coil Hot Water Radiant Heat Other 	1055 = wired floor sensor, or 2000 = Radiant Heat	No	Both	
2130	Backup heat stages	Backup heat stages	<ul style="list-style-type: none"> 1 2 * (Only 1 if 2070 = 2 Radiant Heat stages)	ISU 1055 = Wired or 2000 = Radiant & 2120 = other than None	No	Both	* EIM needed for 2 backup stages.
2150	Backup Heat operation	Backup Heat operation	<ul style="list-style-type: none"> NOT Allowed to Run with Fan Coil Heat Allowed to Run with Fan Coil Heat 	2010 = Hot Water Fan Coil and 2130 = other than 0	No	T10+	
2160	Fan Control	Backup Heat Fan Control	<ul style="list-style-type: none"> Equipment controls fan Thermostat controls fan 	2120 = electric or other	No	Both	
2175	Backup Heat	Aux/E Terminal Control	<ul style="list-style-type: none"> Drive Aux and E together Aux and E independent 	2070 Backup Heat stages = 1	No*	Both	*2175 is not shown and defaults to drive aux and E together when EIM is used.
2180	Backup Heat	Backup Heat Type	<ul style="list-style-type: none"> Electric Forced Air Standard Efficiency Gas Forced Air High Efficiency Gas Forced Air Oil Forced Air Hot Water Fan Coil Hot Water Radiant Heat Other 	2070 Backup Heat stages = 1 or 2	No	Both	

ISU #	Heading	Question	Options	Contingent previous setting?	EIM needed?	T10, T10+ or both	Notes
2185	Emergency Heat	Emergency Heat Type	<ul style="list-style-type: none"> Electric Forced Air Standard Efficiency Gas Forced Air High Efficiency Gas Forced Air Oil Forced Air Hot Water Fan Coil Hot Water Radiant Heat Other 	2175 = independent	No*	Both	*2175 & 2185 are not an option when EIM is used.
2190	External Fossil Fuel Kit	External Fossil Fuel Kit	<ul style="list-style-type: none"> Thermostat Controls Backup Heat External Fossil Fuel Kit Controls Backup Heat 	2000 = heat pump, 2180 = Gas or oil forced air	No	Both	When set for external fossil fuel kit, the thermostat may run the heat pump and backup heat at the same time, assuming the external fossil fuel kit will do the lockouts
2200	Backup Heat Operation	Backup Heat Operation	<ul style="list-style-type: none"> NOT Allowed to Run with Heat Pump Allowed to Run with Heat Pump 	2180 set for Hot Water or Other	No	Both	
2205	Emergency Heat Operation	Emergency Heat Operation	<ul style="list-style-type: none"> NOT Allowed to Run with Heat Pump Allowed to Run with Heat Pump 	2150 set for Hot Water or Other	No*	Both	*2175 and 2205 are not options when EIM is used.
2210	Fan Control	Backup Heat Fan Operation	<ul style="list-style-type: none"> No Fan Equipment controls fan Thermostat controls fan 	2180 = other	No	T10+	
2216	Economizer/ Time of Day	Economizer / Time of Day	<ul style="list-style-type: none"> None Economizer Time of Day 	1010 = Commercial	No	T10+	See wiring diagrams for Economizer
2217	Economizer	What terminals are wired to the Economizer output?	<ul style="list-style-type: none"> U on UWP when EIM isn't used U1-U3 if EIM <u>is</u> used 	2216 = Economizer	No	T10+	See wiring diagrams for Economizer
2218	Time of Day	What terminals are wired to the Time of Day output?	<ul style="list-style-type: none"> U on UWP when EIM isn't used U1-U3 if EIM <u>is</u> used 	2216 = Time of Day	No	T10+	See wiring diagrams for Time of Day
2220	L Terminal alert	What is the L Terminal used for?	<ul style="list-style-type: none"> Economizer Failure indication Heat Pump Fault indication 	Options shown if ISU 2000 = heat pump or 2216= Economizer. If 2054 = Dry Contact, then 2220 is not shown	No	T10+	
2230	Control mode	Control Mode	<ul style="list-style-type: none"> Air and Floor Air only Floor only 	1055 set to Wired	No	T10+	No Floor only option if there is a Cool stage or Backup Heat stage.
2240	Occupancy sensing	Remote Setback	<ul style="list-style-type: none"> No Remote Setback L Terminal (No EIM) Dry contacts (EIM Used) Wireless sensor 	Wireless sensor (s) option requires C7189R2002 or C7189R3002 wireless indoor sensor(s)	No	T10+	See the "Remote Setback (Occupancy Setback / Occupancy Sensor)" on page 105 sections for the uses of this setting, its operation and its wiring options

ISU #	Heading	Question	Options	Contingent previous setting?	EIM needed?	T10, T10+ or both	Notes
3000	Changeover	Changeover	<ul style="list-style-type: none"> Manual Automatic 	Any system with at least 1 Heat stage & 1 Cool stage	No	Both	
3015	Auto Changeover Differential		0-5F (0.00 to 2.50C)	3000= auto	No	Both	
3020	Staging control	Finish with high cool stage	<ul style="list-style-type: none"> No Yes 	2 cool/ compressor stages	No	Both	
3021	Staging control	Finish with high heat stage	<ul style="list-style-type: none"> No Yes 	At least 2 heat stages	No	Both	
3030	Staging control	Cool differential stage 2	<ul style="list-style-type: none"> Comfort 1.0°F / .50°C 1.5°F / .75°C 2.0°F / 1.00°C 2.5°F / 1.25°C 3.0°F / 1.50°C 3.5°F / 1.75°C 	2 cool stages selected	No	Both	
3050	Staging control	Radiant heat differential	<ul style="list-style-type: none"> Comfort 1.0°F / .50°C 1.5°F / .75°C 2.0°F / 1.00°C 2.5°F / 1.25°C 3.0°F / 1.50°C 3.5°F / 1.75°C 	There are 2 stages of radiant heat selected for 2070.	No	Both	
		Heat Differentials	<ul style="list-style-type: none"> Stage 2: Comfort 1.0°F - 3.5°F 	2000 = Conventional Forced air + 2070 = 2 or 3	No	T10+	
			<ul style="list-style-type: none"> Stage 3: Comfort 1.5°F to 4.0°F 	2000 = Conventional Forced air + 2070 = 3	Yes	T10+	
3060	Staging control	Compressor Heat Differential Stage 2	<ul style="list-style-type: none"> Comfort 1.0°F / .50°C 1.5°F / .75°C 2.0°F / 1.00°C 2.5°F / 1.25°C 3.0°F / 1.50°C 3.5°F / 1.75°C 	2000 = Heat Pump and 2070 Compressor stages = 2	No	Both	
3080	Staging control	Backup Heat differentials	Stage 1: <ul style="list-style-type: none"> Comfort* 2.0°F to 15°F (1.00°C to 7.5°C) 	Radiant heat with 1 or 2 backup heat stages	No	Both	*If 2 stages of backup heat. The 2nd backup stage is forced to be at least .5 degrees higher than first stage Backup Heat.
			Stage 2: <ul style="list-style-type: none"> Comfort* 2.5°F to 15.5°F (1.25°C to 7.75°C) 	Radiant heat with 2 backup heat stages	Yes	T10+	

ISU #	Heading	Question	Options	Contingent previous setting?	EIM needed?	T10, T10+ or both	Notes
3090	Staging control	Backup Heat differentials	Stage 1: <ul style="list-style-type: none"> Comfort* 2.0°F to 15°F (1.00°C to 7.5°C) 	Heat pump of FCU with 1 or 2 backup heat stages	No	Both	
			Stage 2: <ul style="list-style-type: none"> Comfort* 2.5°F to 15.5°F (1.25°C to 7.75°C) 	Heat pump selected with 2 Backup Heat stages	Yes	T10+	
3110	Staging control	Backup heat upstage timer	<ul style="list-style-type: none"> Off 30 minutes 45 minutes 60 minutes 75 minutes 90 minutes 2 hours 3 hours 4 hours 5 hours 6 hours 8 hours 10 hours 12 hours 14 hours 16 hours 	3090 set for other than "Comfort"	No	Both	<p>*Comfort setting not available for Dual Fuel.</p> <p>See section on Backup heat differentials, Upstage Timer, and Holdoff Timer.</p> <p>For an FCU, the thermostat will automatically switch to Em Heat mode and run the backup heat if the thermostat had been in heat mode and pipe sensor detects pipe is no longer in the heat temperature threshold.</p> <p>If you don't want to switch to the backup heat when that pipe is warm, set a high Differential setting and set the timers to the maximum settings.</p>
		Backup Heat holdoff timer	<ul style="list-style-type: none"> Auto 15 minutes 30 minutes 45 minutes 60 minutes 75 minutes 90 minutes 105 minutes 120 minutes 	Upstage timer set to other than "Off".	No	T10+	
3120	Equipment Lock-outs	Compressor Lock-out/Balance point	<ul style="list-style-type: none"> Off -15°F to 50°F (-26.0°C to 15.5°C) 	Configured for heat pump with an Aux Heat stage	No	Both	
		Backup Heat Lock-out	<ul style="list-style-type: none"> Off 55°F to 65°F (-15°C to 18.5°C) 		No	Both	
3125	Equipment Lock-outs	Fan Lockout after cool call ends	<ul style="list-style-type: none"> Off 5-120 minutes in 5 minute increments 	2070 = at least 1 cool/compressor stage	No	T10+	This locks out the fan after a cool call even if the fan is set to On or Circ mode or if the fan is set to run for air temperature balancing.
3140	Cycle rates	Cool Cycles Per hour	Stage 1: Settings 1-6	2000 = other than heat pump. 2070 = 1 or 2	No	Both	
			Stage 2: <ul style="list-style-type: none"> Settings 1-6 	2000 = other than heat pump. 2070 = 2	No	Both	
		Compressor Cycles Per Hour	Stage 1: <ul style="list-style-type: none"> Settings 1-6 	2000 = heat pump	No	Both	
			Stage 2: <ul style="list-style-type: none"> Settings 1-6 	2000 = heat pump, 2070 = 2	No	Both	

ISU #	Heading	Question	Options	Contingent previous setting?	EIM needed?	T10, T10+ or both	Notes
3150	Cycle rates	Radiant Heat cycles per hour	Stage 1 • Settings 1-12	At least 1 Radiant Heat stage	No	Both	
			Stage 2 • Settings 1-12	2 Radiant Heat stages	No	T10+	
		Heat Cycles per hour	Stage 1 • Settings 1-12	2000 = Conventional Forced Air, or Other	No	Both	
			Stage 2 • Settings 1-12	2000 = Conventional Forced Air & 2070 = 2-3 heat stages	No	Both	
	Stage 3 • Settings 1-12		2000 = Conventional Forced Air & 2070 = 3 heat stages	Yes	T10+		
	Primary Heat Cycles per hour	Settings 1-12	2010		T10+	Added to firmware versions 03.03.08.02 and later	
3160	Cycle rates	Backup heat cycles per hour	Backup heat cycles per hour • Settings 1-12	2130 = at least 1 Backup Heat stage selected	No	Both	
		Backup heat cycles per hour	Backup heat cycles per hour stage 2 • Settings 1-12	2130 = 2 Backup Heat stage selected	Yes	T10+	
3240	Temperature Control	Minimum Fan Coil Off Time	Settings: • Off • 1-5 minutes in 1-minute increments				
3250	Temperature Control	Minimum non-compressor on time	• Off • 2 minutes • 5 minutes	2000 = Radiant Heat	No	T10+	

ISU #	Heading	Question	Options	Contingent previous setting?	EIM needed?	T10, T10+ or both	Notes
3260	Temperature Control	Extended fan run times	Extended fan run time in Cool: <ul style="list-style-type: none"> • Off • 30 seconds • 60 seconds • 90 seconds • 2 minutes • 3 minutes • 4 minutes • 5 minutes • 6 minutes • 7 minutes • 8 minutes • 9 minutes • 10 minutes • 11 minutes • 12 minutes • 13 minutes • 14 minutes • 15 minutes 	At least 1 cool stage	No	Both	
			Extended fan run time in Heat: <ul style="list-style-type: none"> • Off • 30 seconds • 60 seconds • 90 seconds • 2 minutes • 3 minutes • 4 minutes • 5 minutes • 6 minutes • 7 minutes • 8 minutes • 9 minutes • 10 minutes • 11 minutes • 12 minutes • 13 minutes • 14 minutes • 15 minutes 	At least 1 Heat stage	No	Both	
3300	Temperature Control	Temperature Balancing	<ul style="list-style-type: none"> • Off • On 		No	T10+	See "Temperature balancing (T10+ model only)" on page 82.
3310	Temperature Control	Temperature Balancing Room Delta	<ul style="list-style-type: none"> • 0.5°F to 10°F in .5°F increments (.25°C to 5°C in 2.5°C increments) 				
3320	Fan Control	Fan Modes Allowed	<ul style="list-style-type: none"> • Auto • Multiple Speeds • Auto & Multiple Speeds 	2105 = 2 or 3	No	T10+	For settings and options: See "Fan Coil Unit Settings and Operation" on page 104
3325	Fan Control	Start Fan on the Highest Stage	<ul style="list-style-type: none"> • Off • On 	2105 = 2 or 3		T10+	
3340	Fan Control	Fan reset to Auto Mode timer	<ul style="list-style-type: none"> • Off • 2 hours • 4 hours 	2010 = 2-pipe or 4-pipe		T10+	

ISU #	Heading	Question	Options	Contingent previous setting?	EIM needed?	T10, T10+ or both	Notes
4010	Fan Control	Pre-Occupancy Purge Duration	<ul style="list-style-type: none"> Off 1 hour 2 hours 3 hours 	1010 = Light Commercial	No	T10+	Run fan prior to occupied period
4020	Type of Override	Type of Override	<ul style="list-style-type: none"> Standard Initiate Occupancy 	1010 = Light Commercial	No	T10+	See description in "Commercial Features" on page 112.
4030	Override Duration	Override Duration	<ul style="list-style-type: none"> No limit 1 - 12 hours in 1 hour increments 	1010 = Light Commercial	No	T10+	
4050	Temperature Control	Heat Recovery Ramp Rate (cold day)	<ul style="list-style-type: none"> Off 1°F-20°F per hour in 1°F increments 	1010 = light commercial. 1060 (Outdoor Temperature) must be set to other than "None", to see the outdoor temp settings for 4050-4080. If set to "Wired", 5050 must also be set to other than "None"	No	T10+	The heating system will begin recovery at the time that is scheduled. When a Minimum Recovery Ramp Rate is set, the thermostat will begin recovery early to ensure that the temperature is reached at the scheduled time. Set a Minimum Recovery Ramp Rate based on the rate that the heating system can recover at for a cold day in your region. Default setting is 5F / hour. Set an Outdoor Temperature that is representative of a cold day in your region to be associated with the Minimum Recovery Ramp Rate. The thermostat will begin recovery at the optimal time based on a calculated ramp rate. During recovery, the setpoint changes at a rate in degrees per hour depending on the outdoor sensor, the Minimum Recovery Ramp Rate is used.
		Outdoor Temperature	<ul style="list-style-type: none"> -20°F through 120°F in 1 degree F increments 				
4060	Temperature Control	Heat Recovery Ramp Rate (mild day)	<ul style="list-style-type: none"> Off 1°F-20°F per hour in 1°F increments 				
		Outdoor Temperature	<ul style="list-style-type: none"> -20°F through 120°F in 1°F increments 				
4070	Temperature Control	Cool Recovery Ramp Rate (hot day)	<ul style="list-style-type: none"> Off 1F-20°F per hour in 1 degree F increments 				
		Outdoor Temperature	<ul style="list-style-type: none"> -20°F through 120°F in 1 degree F increments 				
4080	Temperature Control	Cool Recovery Ramp Rate (mild day)	<ul style="list-style-type: none"> Off 1°F-20°F per hour in 1 degree F increments 				
		Outdoor Temperature	<ul style="list-style-type: none"> -20°F through 120°F in 1 degree F increments 				
4090	Temperature Control	Adaptive Intelligent Recovery	<ul style="list-style-type: none"> No Yes 		No	Both	
4100	Range Stops	Temperature range stops	Minimum cool setpoint; 50F-99F (10C-37C)	At least 1 stage of cool	No	Both	There is a correlation between these settings. For example, if minimum cool is set to 50F, minimum heat cannot be set above 40F
			Maximum cool setpoint; 90F-99F (32C-37C)	At least 1 stage of cool	No	Both	
			Minimum heat setpoint; 40F-50F (4.5C-10C)	At least 1 stage of Heat	No	Both	
			Maximum heat setpoint; 40F-90F (4.5 - 32.0C)	At least 1 stage of Heat	No	Both	
4110	Keypad lockout	Keypad lockout	Unlocked, partially locked, fully locked		No	Both	

ISU #	Heading	Question	Options	Contingent previous setting?	EIM needed?	T10, T10+ or both	Notes
5000	Sensors	What sensors are WIRED to your system?	<ul style="list-style-type: none"> Indoor Air Temperature Outdoor Air Temperature Return Air Temperature Discharge Air Temperature Floor Temperature Fan Coil Changeover Temperature 	Floor sensor only shown here if 1055 is set to Wired . Fan Coil Changeover Temperature only shown if 2054 = 10k or 20k	No	Return, Discharge, Floor and Fan Coil Change-over are for T10+ only.	
5020	Sensors	What Terminals are Wired to the Indoor Temperature Sensor?	<ul style="list-style-type: none"> None Thermostat S1 EIM S1 EIM S2 EIM S3 EIM S4 	5000 has Indoor Sensor selected	No	Both	Options depend on whether EIM is used.
5030	Sensors	Indoor Temperature Sensor Type	<ul style="list-style-type: none"> 10K 20K 	5000 has Indoor Sensor selected	No	Both	
5040	Sensors	Which Sensors will be used for TEMPERATURE Control? (Multiple sensors are averaged)	<ul style="list-style-type: none"> Thermostat Indoor sensor (remote) 	5000 set for Wired Indoor Sensor	No	Both	
5050	Sensors	What Terminals are Wired to the Outdoor Air Temperature Sensor?	<ul style="list-style-type: none"> None Thermostat S1 EIM S1 EIM S2 EIM S3 EIM S4 	1060 set to Wired	No	Both	Options depend on whether EIM is used.
5070	Sensors	What Terminals are Wired to the Return Air Temperature Sensor?	<ul style="list-style-type: none"> None Thermostat S1 EIM S1 EIM S2 EIM S3 EIM S4 	5000 has Return Sensor selected		T10+	Options depend on whether EIM is used.
5080	Sensors	Return Temperature Sensor Type	<ul style="list-style-type: none"> 10K 20K 	5000 has Return sensor selected	No	T10+	
5090	Sensors	What Terminals are Wired to the Discharge Air Temperature Sensor?	<ul style="list-style-type: none"> None Thermostat S1 EIM S1 EIM S2 EIM S3 EIM S4 	5000 has Discharge Sensor selected	No	T10+	Options depend on whether EIM is used.
5100	Sensors	Discharge Temperature Sensor Type	<ul style="list-style-type: none"> 10K 20K 	5000 has Discharge Sensor selected	No	T10+	
5110	Sensors	A-Coil Low Temperature Cutoff	<ul style="list-style-type: none"> Off, 5°F to 65°F (-15°C to 18.5°C) 	At least 1 cool stage	No	T10+	

ISU #	Heading	Question	Options	Contingent previous setting?	EIM needed?	T10, T10+ or both	Notes
5120	Sensors	What Terminals are Wired to the Floor Temperature Sensor?	<ul style="list-style-type: none"> None Thermostat S1 EIM S1 EIM S2 EIM S3 EIM S4 	1055 set to "Wired"	Yes	T10+	Options depend on whether EIM is used.
5150	Floor Temperature Limits	Minimum Limit	Minimum Limit = 40°F-89°F (4.5°C to 31.5°C)	ISU 2230 = Air & Floor	No	T10+	Top range affected by Maximum limit setting
		Maximum Limit	Maximum Limit = 50°F-99°F (10.0°C to 37.0°C)		No	T10+	Bottom range affected by Minimum limit setting
5160	Floor Economy Mode	Floor Economy Mode	<ul style="list-style-type: none"> Yes No 	5000 has Floor Sensor selected	No	T10+	If enabled, Low Floor Temperature Limit (ISU 5150) will be disabled during Away and Sleep period. This ISU is only displayed if Temperature Control Mode (ISU 2230) is set to AF mode.
5170	Freeze Protection	Freeze Protection	<ul style="list-style-type: none"> Off 40°F-50°F (4.5°C to 10°C) (Off only available for non-radiant systems)	Cannot be below minimum setting in 5150 (if used).	No	T10+	The thermostat operates the heat whenever the room temperature falls below that limit, even when the system is set to off. Default setting is Off (disabled) for non-radiant systems and 40°F (4.5°C) for radiant systems. Freeze protection temperature cannot be set above ISU 5150 minimum setting.
5200	Changeover Setup	Temperature Thresholds	<ul style="list-style-type: none"> Cooling Threshold 50°F-72°F (10°C to 22°C) Heating Threshold 75°F-90°F (24°C to 32°C) 	5000 = Fan coil changeover	No	T10+	See "Fan Coil Unit Settings and Operation" on page 104
6000	Dry Contacts	Select the Dry Contacts in the System	<ul style="list-style-type: none"> Remote Setback Full Drain Pan Alert Dirty Filter Alert Water Leak Alert System Shutdown Alert Service Needed Alert Fan Failure Alert 		Yes	T10+	See "Dry Contact Alerts (ISU 6000- 6220)" on page 109 for operation details
6005	Custom Dry Contact alerts	Select Custom Dry Contact alerts	<ul style="list-style-type: none"> Custom Alert 1 Custom Alert 2 Custom Alert 3 Custom Alert 4 		Yes	T10+	See "Dry Contact Alerts (ISU 6000- 6220)" on page 109 for operation details

ISU #	Heading	Question	Options	Contingent previous setting?	EIM needed?	T10, T10+ or both	Notes
6010	Dry Contacts	What terminals are wired to the Remote Setback Dry Contact?	<ul style="list-style-type: none"> None EIM S1 EIM S2 EIM S3 EIM S4 	6000 = Remote Setback	Yes	T10+	See "Remote Setback (Occupancy Setback / Occupancy Sensor)" on page 105
6020	Dry Contacts	Remote Setback Dry Contact Setup	<ul style="list-style-type: none"> Normally Open when Occupied Normally Closed when Occupied 	2240 = L terminal or 6010 = S1-S4	No	T10+	
6030	Dry Contacts	Remote Setback Time Delayed from Occupied to Unoccupied	0 Minutes to 30 Minutes in 5 minute increments	2240 = Other than "None"	No	T10+	
6040	Dry Contacts	Remote Setback – Standby Cool Setpoint	72°F-90°F				
		Remote Setback – Standby Heat Setpoint	50°F-70°F				
6050	Dry Contacts	What terminals are wired to the Full Drain Pan Alert dry contact?	<ul style="list-style-type: none"> None EIM S1 EIM S2 EIM S3 EIM S4 	6000 has full drain pan selected	Yes	T10+	See "Dry Contact Alerts (ISU 6000- 6220)" on page 109 for operation details
6060	Dry Contacts	Full Drain Pan Alert dry contact setup	<ul style="list-style-type: none"> Normally open Normally closed 	6000 has full drain pan selected	Yes	T10+	
6065	Dry Contacts	Full Drain Pan Alert dry contact actions	System shutdown <ul style="list-style-type: none"> Select De-select 	6000 has Full Drain Pan selected	Yes	T10+	
6070	Dry Contacts	What terminals are wired to the Dirty Filter Alert dry contact?	<ul style="list-style-type: none"> None EIM S1 EIM S2 EIM S3 EIM S4 	6000 has Dirty Filter Alert selected	Yes	T10+	
6080	Dry Contacts	Dirty Filter Alert dry contact setup	<ul style="list-style-type: none"> Normally open Normally closed 		Yes	T10+	
6090	Dry Contacts	What terminals are wired to the Water Leak Alert dry contacts?	<ul style="list-style-type: none"> None EIM S1 EIM S2 EIM S3 EIM S4 	6000 has water leak selected	Yes	T10+	See "Dry Contact Alerts (ISU 6000- 6220)" on page 109 for operation details
6100	Dry Contacts	Water Leak Alert dry contact setup	<ul style="list-style-type: none"> Normally open Normally closed 	6000 has water leak selected	Yes	T10+	
6110	Dry Contacts	What terminals are wired to the System Shutdown Alert dry contact?	<ul style="list-style-type: none"> None EIM S1 EIM S2 EIM S3 EIM S4 	6000 has system shut down alert selected	Yes	T10+	See "Dry Contact Alerts (ISU 6000- 6220)" on page 109 for operation details
6120	Dry Contacts	System shut down alert dry contact setup	<ul style="list-style-type: none"> Normally open Normally closed 		Yes	T10+	

ISU #	Heading	Question	Options	Contingent previous setting?	EIM needed?	T10, T10+ or both	Notes
6130	Dry Contacts	What terminals are wired to the Service Needed Alert dry contact?	<ul style="list-style-type: none"> None EIM S1 EIM S2 EIM S3 EIM S4 	6000 has Service Needed Alert selected	Yes	T10+	See "Dry Contact Alerts (ISU 6000- 6220)" on page 109 for operation details
6140	Dry Contacts	Service Needed Alert dry contact setup	<ul style="list-style-type: none"> Normally open Normally closed 		Yes	T10+	
6150	Dry Contacts	What terminals are wired to the Fan Failure Alert dry contact?	<ul style="list-style-type: none"> None EIM S1 EIM S2 EIM S3 EIM S4 	6000 has Fan Failure Alert selected	Yes	T10+	See "Dry Contact Alerts (ISU 6000- 6220)" on page 109 for operation details
6160	Dry Contacts	Fan Failure Alert dry contact setup	<ul style="list-style-type: none"> Normally open Normally closed 		Yes	T10+	
6190	Dry Contacts	What terminals are wired to the custom alert 1 dry contact?	<ul style="list-style-type: none"> None EIM S1 EIM S2 EIM S3 EIM S4 	6005 has custom alert 1 selected	Yes	T10+	See "Dry Contact Alerts (ISU 6000- 6220)" on page 109 for operation details
6200	Dry Contacts	Custom alert 1 dry contact setup	<ul style="list-style-type: none"> Normally open Normally closed 		Yes	T10+	
6210	Dry Contacts	Custom Alert 1 Name	Type in the alert name		Yes	T10+	
6215	Dry Contacts	Show custom alert 1 message	<ul style="list-style-type: none"> Yes No 		Yes	T10+	
6220	Dry Contacts	Custom Alert 1 Message	Type in the message displayed when this alert is active	6215 set to Yes	Yes	T10+	See "Dry Contact Alerts (ISU 6000- 6220)" on page 109 for operation details
6230	Dry Contacts	Custom alert 1 actions	<ul style="list-style-type: none"> Lock out Heat Lock out Cool Activate fan Activate custom U terminal 	6005 has custom alert 1 selected			
6240	Dry Contacts	What terminals are wired to custom U contact?	<ul style="list-style-type: none"> EIM U1 EIM U2 EIM U3 	6230 has custom U terminal selected	Yes	T10+	When the switch wired to the S terminals for the Custom Dry Contact Alert activates, the custom U contacts will change state to activate or shut off whatever is wired to those terminals
6250	Dry Contacts	Custom U dry contact name	Type in the name of whatever the custom U Dry Contact is controlling				
6260	Dry Contacts	Custom U dry contact setup	<ul style="list-style-type: none"> Normally open Normally closed 				
6300 - 6370	These are duplicate settings to 6190-6260 but for Dry Contact Alert 2 (if selected)			6005 has custom Dry Contact Alert 2 selected	Yes	T10+	
6400 - 6470	These are duplicate settings to 6190-6260 but for Dry Contact Alert 3 (if selected)			6005 has custom Dry Contact Alert 3 selected	Yes	T10+	

ISU #	Heading	Question	Options	Contingent previous setting?	EIM needed?	T10, T10+ or both	Notes
6500-6570	These are duplicate settings to 6190-6260 but for Dry Contact Alert 4 (if selected)			6005 has custom Dry Contact Alert 4 selected	Yes	T10+	
6600	Dry contacts	Cool Lockout Delay Time	<ul style="list-style-type: none"> Off 5-60 minutes in 5 minute increments 	6230, 6340, 6440, or 6540 set to lock out cool	Yes	T10+	See "Dry Contact Alerts (ISU 6000- 6220)" on page 109 for operation details
6610	Dry contacts	Cool lockout maximum indoor temperature	<ul style="list-style-type: none"> None 80°F-99°F 		Yes	T10+	
6620	Dry contacts	Heat Lockout Delay Time	<ul style="list-style-type: none"> Off 5-60 minutes in 5 minute increments 	6230, 6340, 6440, or 6540 set to lock out Heat	Yes	T10+	
6630	Dry contacts	Heat lockout minimum indoor temperature	<ul style="list-style-type: none"> None 40°F-60°F 		Yes	T10+	
6640	Dry contacts	Minimum Off Time	<ul style="list-style-type: none"> Off 1-5 minutes 	6230, 6340, 6440, or 6540 set to lock out Heat or Cool	Yes	T10+	
7000	Filtration	Filter type	<ul style="list-style-type: none"> None Electronic air cleaner Media 		No	Both	
7020	Filtration	Number of air filters	<ul style="list-style-type: none"> 0 1 2 	7000 = media	No	Both	
7110	Filtration	Replacement reminders	Air Filter 1 settings and Air Filter 2 settings: <ul style="list-style-type: none"> Off 10 Run time days 20 Run time days 30 Run time days 45 Run time days 60 Run time days 90 Run time days 120 Run time days 150 Run time days 30 Calendar days 45 Calendar days 60 Calendar days 75 Calendar days 3 Calendar months 4 Calendar months 5 Calendar months 6 Calendar months 9 Calendar months 12 Calendar months 15 Calendar months 	7020 = 1 or 2	No	Both	
				7020 = 2	No	Both	

ISU #	Heading	Question	Options	Contingent previous setting?	EIM needed?	T10, T10+ or both	Notes
7120	Filtration	Electronic Air Cleaner Reminders	Clean cells, options: <ul style="list-style-type: none"> Off 6-12 calendar months 	7000 = electric	No	Both	
			Clean Pre-filters, options: <ul style="list-style-type: none"> Off 6-12 calendar months 		No	Both	
			Replace Post-filters, options: <ul style="list-style-type: none"> Off 6-12 calendar months 		No	Both	
8000	Humidification	What type of humidifier do you have?	<ul style="list-style-type: none"> None Steam Bypass Fan powered 	U contacts not already used	No	Both	
8010	Humidification	What sensors will be used for Humidification control	<ul style="list-style-type: none"> Thermostat Wireless sensors 	8000 = other than None & Wireless sensor connected to thermostat	No	T10+	
8030	Humidification	What terminals are wired to the humidifier?	<ul style="list-style-type: none"> None Thermostat U1 EIM U1 EIM U2 EIM U3 		Yes	T10+	Thermostat U1 only shown when EIM not used
8050	Humidification	Humidification Window Protection	<ul style="list-style-type: none"> Off On 	1060 & 8000 = other than "none". Need wired or wireless outdoor sensor for this feature	No	Both	See "Window Protection" on page 94 for more details
8060	Humidification	System modes allowing humidification	<ul style="list-style-type: none"> Heat Cool and/or Off 	8000 = other than "None". (Cool option only when discharge sensor selected ISU 5000)	No	Both (cool only for T10+ with DATS)	
8070	Humidification	Humidification control	<ul style="list-style-type: none"> Humidify Only when heat is on Humidify Only when fan is on Humidify on demand: Thermostat controls fan Humidify on demand: Humidifier controls fan 	8000 set to other than None	No	Both	
8080	Humidification	Humidifier Lockout	<ul style="list-style-type: none"> Humidifier allowed when Cool is running Humidifier not allowed when Cool is running 	8060 set to Cool	No	T10+	

ISU #	Heading	Question	Options	Contingent previous setting?	EIM needed?	T10, T10+ or both	Notes
8095	Humidification	Humidifier Lockouts Dry Contacts	<ul style="list-style-type: none"> Full Drain Pan Water leak Custom Alerts 1 - 4 	8000 = steam, by-pass or fan powered, & 6000 = full drain pan or water leak, OR 6005 is set for custom Dry Contact Alert	Yes	T10+	This will lock out the humidifier when the associated Dry Contact Alert is active
8100	Humidification	Humidifier Pad replacement reminder	<ul style="list-style-type: none"> Off 6 or 12 calendar months 	8000 = none, or bypass or fan powered	No	Both	
8100	Humidification	Clean tank/Water Filter replacement Reminder	<ul style="list-style-type: none"> Off 60 or 90 run time days 6 or 12 calendar months 	8000 = steam	No	Both	
9000	Dehumidification	What type of dehumidification equipment do you have?	<ul style="list-style-type: none"> None A/C with low speed fan A/C with high speed fan Whole House Dehumidifier Hot Gas Bypass 	A/C with low speed fan Dehumidifier & Hot Gas Bypass only shown if U contacts are available	No	Hot Gas Bypass only for T10+	
9005	Dehumidification	Dehumidification Fan speed priority	<ul style="list-style-type: none"> Low speed fan with Cool stage 1 only Low speed fan Always. Selectable by user, 	9000 = A/C with Low Speed Fan	No	T10+	
9010	Dehumidification	What sensors will be used for Humidification control	<ul style="list-style-type: none"> Thermostat Wireless sensors 	9000 = A/C with Low Speed Fan, Whole House Dehumidifier, or Hot Gas Bypass	No	T10+	
9040	Dehumidification	What terminals are wired to the dehumidification equipment?	<ul style="list-style-type: none"> None Thermostat U EIM U1 EIM U2 EIM U3 	9000 = A/C with Low Speed Fan or Whole House Dehumidifier	Yes	T10+	Thermostat U1 only shown when EIM not used
9050	Dehumidification	Dehumidification Equipment Setup	<ul style="list-style-type: none"> Normally Open Normally Closed 	9000 = Low Speed Fan or Hot Gas Bypass	No	Both	
9070	Dehumidification	Dehumidification - Overcooling Limit	<ul style="list-style-type: none"> 0°F (0°C) 1°F (0.5°C) 2°F (1.0°C) 3°F (1.5°C) 	9000 = A/C with High or Low Speed Fan	No	Both	If Celsius is selected in ISU 1050, the Celsius temperatures seen in the Options column at left are presented.

ISU #	Heading	Question	Options	Contingent previous setting?	EIM needed?	T10, T10+ or both	Notes
9080	Dehumidification	Control Method	<ul style="list-style-type: none"> Basic Minimum on Time High Humidity Comfort Reset High Humidity Comfort Reset w/ Minimum On Time Reheat Reheat with Minimum On Time 	Set for Light Commercial	No	T10+	<p>Some of these settings originated with the Factory/Over-The-Air release of firmware version 03.03.08.02, which supports Light Commercial settings.</p> <p>ISU 9080-9100 were part of this update.</p> <p>The T10+ will receive this OTA update when the thermostat is connected to WiFi and registered to an account. Note that the OTA update may take as long as one day after connection and registration.</p>
9090	Dehumidification	Dehumidification Minimum On Time	<ul style="list-style-type: none"> 0 minutes 5 minutes to 15 minutes in 1 minute increments 	9080 = other than Basic	No	T10+	
9100	Dehumidification	High Humidity Comfort Reset Setting	1°F to 5°F in 1°F increments	9080 = one of the Comfort Reset settings	No	T10+	
9120	Dehumidification	System modes allowing dehumidification	<ul style="list-style-type: none"> Heat Off Cool 	9000 - Whole House Dehumidifier	No	Both	
9130	Dehumidification	Dehumidifier Fan Control	<ul style="list-style-type: none"> Thermostat Controls Fan Dehumidifier Controls Fan 	9000 - Whole House Dehumidifier	No	Both	
9140	Dehumidification	Dehumidifier Lock-out	<ul style="list-style-type: none"> Dehumidifier Allowed when Cool is Running Dehumidifier Not Allowed when Cool is Running 	9000 - Whole House Dehumidifier	No	Both	
9145	Dehumidification	Dehumidifier lock-out dry contact	Custom Alert 1 - Custom Alert 4 (options depend on 6005 settings)	ISU 6005 is set for a custom dry contact alert	Yes	T10+	If enabled, the dehumidifier will lock out whenever the selected Dry Contact Alert is active
9180	Dehumidification	Dehumidification - Away mode	<ul style="list-style-type: none"> Not Allowed Allowed 		No	T10+	
9190	Dehumidification	Dehumidification Away mode Fan Control	<ul style="list-style-type: none"> On Automatic Circulate 	9180 = allowed	No	T10+	
9200	Dehumidification	Dehumidification Away mode low limit temperature setting	70°F-80°F (21.0°C-26.5°C)	9180 = allowed	No	T10+	The dehumidification Away mode setting can restrict this
		Dehumidification Away Mode Temperature Setting	70°F to 99°F (21.0°C to 37.0°C)	9180 = allowed	No	T10+	The dehumidification Away mode Low Limit setting can restrict this
		Dehumidification Away Mode Dehumidification Setting	40% - 70%	9180 = allowed	No	T10+	

ISU #	Heading	Question	Options	Contingent previous setting?	EIM needed?	T10, T10+ or both	Notes
9210	Dehumidification	Dehumidifier Filter replacement reminder	<ul style="list-style-type: none"> Off 30 Calendar Days 60 Calendar Days 3 Calendar Months 4 Calendar Months 5 Calendar Months 6 Calendar Months 7 Calendar Months 8 Calendar Months 9 Calendar Months 10 Calendar Months 11 Calendar Months 12 Calendar Months 		No	Both	
10000	Ventilation	Ventilation Type	<ul style="list-style-type: none"> None ERV/HRV Passive (Fan Only) Fresh Air Damper 	ERV/HRV or Damper needs available U contacts. Passive Fan is <u>not</u> an option for Radiant Heat Only.	No	Both	
10005	Ventilation	Ventilator Model number	Other model <ul style="list-style-type: none"> VNT5070E1000 VNT5200E1000 VNT5150E2000 VNT5150H2000 VNT5200E2000 VNT5200H2000 	ISU 10000 set to ERV/ HRV	No	T10+	See " Ventilation " on page 98.
10020	Ventilation	What terminals are wired to the ventilation equipment?	<ul style="list-style-type: none"> None Thermostat U1 EIM U1 EIM U2 EIM U3 	10000 = ERV/HRV or Fresh Air Damper	Yes	T10+	Thermostat U1 only shown when EIM not used.
10050	Ventilation	Ventilation control method	<ul style="list-style-type: none"> ASHRAE Percent on Time 	10000 = ERV/HRV or Fresh Air Damper	No	Both	
10060	Ventilation	Ventilation Fan control	<ul style="list-style-type: none"> Thermostat controls fan Equipment controls fan 	10000 = ERV/HRV or Fresh Air Damper and 8000 set for Humidifier	No	Both	
10065	Ventilation	Turn on ventilation dry contacts	<ul style="list-style-type: none"> Custom Alert 1 - Custom Alert 4 (options depend on 6005 settings) 	ISU 6005 is set for a custom dry contact alert & ISU 10140 isn't selected for the same custom alert.	Yes	T10+	If enabled, the ventilator will come on whenever the selected Dry Contact Alert is active
10090	Ventilation	Ventilation House Size	Number of Bedrooms 1-6	10050 = ASHRAE	No	Both	
			Size of house: <ul style="list-style-type: none"> 1000 -5000 square feet if display set to Fahrenheit 90-460 square meters if set to Celsius 	10050 = ASHRAE	No	Both	

ISU #	Heading	Question	Options	Contingent previous setting?	EIM needed?	T10, T10+ or both	Notes
10100	Ventilation	Enter Equipment Ventilation Rate	<ul style="list-style-type: none"> 30 - 350 CFM if display set to Fahrenheit 850 - 9900 LPM if set to Celsius 	10050 = ASHRAE	No	Both	Fixed setting and not adjustable if VNT5070 or VNT5200 is selected for 10005. This setting also indicates whether or not you meet ASHRAE standards if ISU 10050 = ASHRAE based on ISU 10090 settings
10120	Ventilation	Ventilation Percent On Time	10% - 100% (30% default)	10050 + % on time	No	Both	
10125	Ventilation	Ventilation Priority	<ul style="list-style-type: none"> Lockouts are priority ASHRAE is priority 	10050 = ASHRAE	No	Both	
10130	Ventilation	Outdoor condition lockouts	Low Temperature = off, -20F to 40F (off, -29.0 - 4.5C)	10000 = ERV/HRV or Fresh air damper & 1060 (outdoor temperature) = other than "None"	No	Both	
			High Temperature = off, 80F to 110F (off, 26.5C-43.5C)		No	Both	
			High Dew point = off, 65F - 85F (Off, 18.5C-29.5C)	1060 = Internet or Wireless	No	Both	
10140	Ventilation	Lockout Ventilation on Humidification or dehumidification calls	Off or On	8000 set for humidifier and/or 9000 set for dehumidifier	Yes	T10+	
10145	Ventilation	Ventilation lockout dry contacts	<ul style="list-style-type: none"> Custom Alert 1 - Custom Alert 4 (options depend on 6005 settings) 	ISU 6005 is set for a custom dry contact alert & ISU 10065 isn't selected for the same custom alert.	Yes	T10+	If enabled, the ventilator will be locked out whenever the selected Dry Contact Alert is active
10160	Ventilation	Ventilate on high indoor humidity	Off, On (Heat only)	8000 set for humidifier and 10000 set for ventilator	Yes	T10+	
10170	Ventilation	Ventilation Reminders	Clean core = Off, 3, 6, 9, 12, calendar months	Core only shown if 100 = ERV/HRV. Filter reminder always shown.	No	Both	
			Clean filter = Off, 3, 6, 9, 12, calendar months		No	Both	
11000	UV Devices	Number of UV Devices	0, 1, 2		No	Both	
11050	UV Devices	UV Bulb Replacement Reminders	Replace UV Bulb 1 = Off, 6, 12, 24 calendar months	11000 = 1 or 2	No	Both	
			Replace UV Bulb 2 = Off, 6, 12, 24 calendar months	11000 = 2	No	Both	
14005	Idle screen Style	Idle screen Style	<ul style="list-style-type: none"> Temperature Analog Clock 		No	Both	
14010	Clock Format	Clock Format	<ul style="list-style-type: none"> 12 hour clock 24 hour clock 		No	Both	

ISU #	Heading	Question	Options	Contingent previous setting?	EIM needed?	T10, T10+ or both	Notes
14015	Daylight Savings Time	Daylight Savings Time	<ul style="list-style-type: none"> • Off • On 		No	Both	
14020	Display Offsets	Indoor Display Offsets	<ul style="list-style-type: none"> • Indoor Temperature: • 0°F • 1°F • 2°F • 3°F 		No	Both	The display offset is applied to the Home screen, not the Priority screen. This offset is not associated with any individual sensor.
			Indoor Humidity: -12% to 12% RH		No	Both	
14030	Display Offsets	Outdoor Display Offsets	<ul style="list-style-type: none"> • Outdoor Temperature: • 0°F • 1°F • 2°F • 3°F 		No	T10+	T10+ Linked to C7089R3013 wireless outdoor sensor
			Outdoor Humidity: -12% to 12% RH				
14050	Indoor humidity	Show indoor humidity on home screen	Yes, No		No	T10+	If set to control a humidifier or dehumidifier, the T10+ will still show the indoor humidity reading under the Humidity and Dehumidity setting screens
15000	Dealer Information	Dealer Information	Enter Company name, phone number, website, email, message		No	Both	

WIFI SETUP

During the initial installation, after the Installer setup the thermostat will prompt you to set up WiFi and guide you through the steps. If you are setting up WiFi after the initial installation has already been done, follow the steps below:

1. Select the **Main Menu** icon.

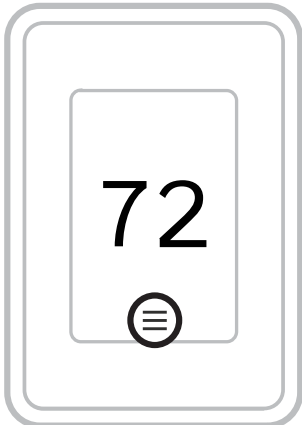

M37797

Main menu icon.

2. Then select **WiFi**.
3. There is a slider labeled “Enable WiFi”. Make sure this is set to the right.
4. Touch **Choose Network**.
5. After a brief delay, the thermostat should show the available networks. Choose your home network from the list.
6. If this is a secure network, it should prompt you to “Enter WiFi password”. After a brief delay the display should show “Success! Your thermostat successfully connected to the network.” Press the **OK** button. NOTE: If you did not successfully connect to the network:
7. Download the First Alert or Resideo app from the App store or Google Play.
8. Open the First Alert or Resideo app. Tap **SET UP NOW** as shown here to continue. Tap **INSTALL A DEVICE** and follow the prompts to continue. The app will walk you through the rest of the setup.



M37798

SET UP NOW screen

Connect to a Hidden WiFi Network

1. Touch **MENU**, then WiFi Setup.
2. Touch **Other**, then **Select**.
3. When prompted, press the screen to edit the network name.
4. Enter the network name.

Press the ▲ or ▼ buttons to change the letter or number. Press the ► button to move to the next character, or the ◀ button to move to the previous character. Use the ▲ or ▼ buttons at the bottom to change letter case. Press Done when complete.

5. Select the appropriate network security setting, then press Select.
6. Enter the WiFi network password as explained above in “Connecting to WiFi Network”, step 6.

Unsuccessful WiFi Connection

If you are unsuccessful in connecting the thermostat to the WiFi network, you will see a Connection Failed screen. Press the ▼ button for other tips about this failed connection. Here are three specific reasons the connection might be unsuccessful.

For all Connection Failed screens, pressing Done will return to the Menu screen.

Invalid Password

The password you entered is invalid. Check that you have the right password and try again.

No IP Address

The thermostat was unable to obtain an IP address from the router. Verify the router is correctly set up to automatically assign IP addresses. This connection can take several minutes. If there is still no connection, remove the thermostat from the wallplate for 10 seconds, then snap it back into place.

No Internet Link

The thermostat connected to the WiFi network but was unable to establish a connection to the internet. Check the router settings and try again. Make sure the Ethernet cable is plugged into the router and try rebooting the router if necessary.

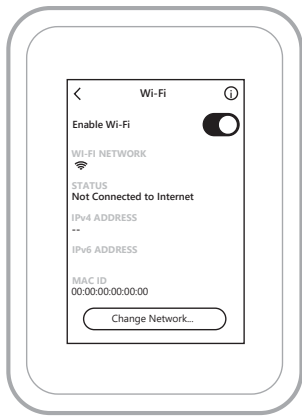

SCHEDULING

Setting a Schedule On Thermostat

Select the **MENU** icon at the bottom of the home screen display. Then select **Schedule**.

- If you want all days the same, select **Grouped Days**.
- Touch the period you wish to edit (**Wake, Away, Home** or **Sleep**).

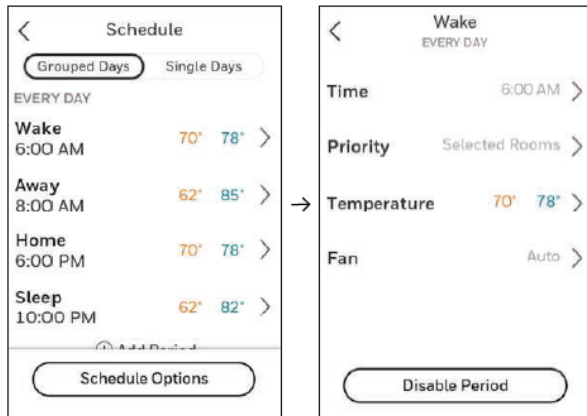

Residential

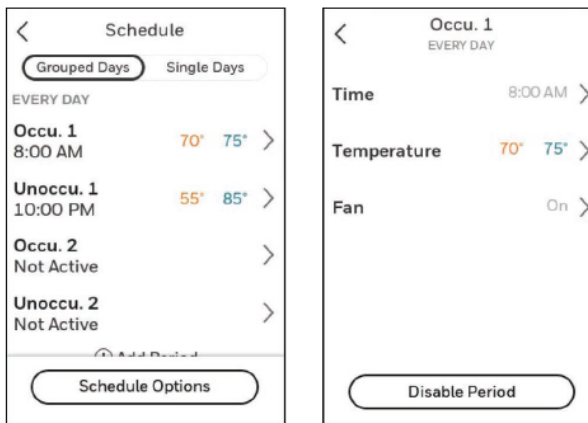

Commercial

- If you want all days separate, select **Single Days**.
- Touch the period of the day you wish to edit (**Wake, Away, Home, or Sleep**). Scroll down to see additional days).

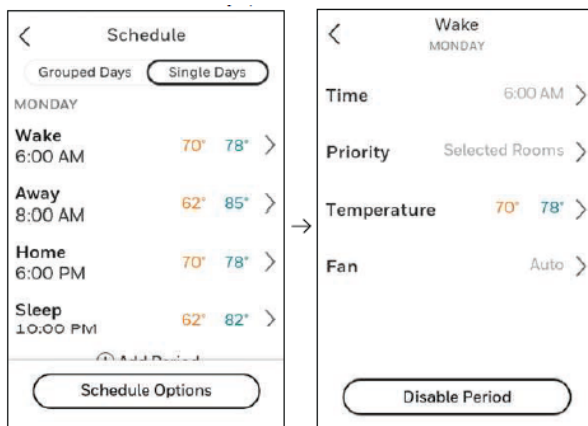

- If you want weekdays grouped but weekend days separate, or if you do not want to use a schedule, select **Schedule**.

- Touch **Create New Schedule**. The thermostat will then walk you through the schedule setup.

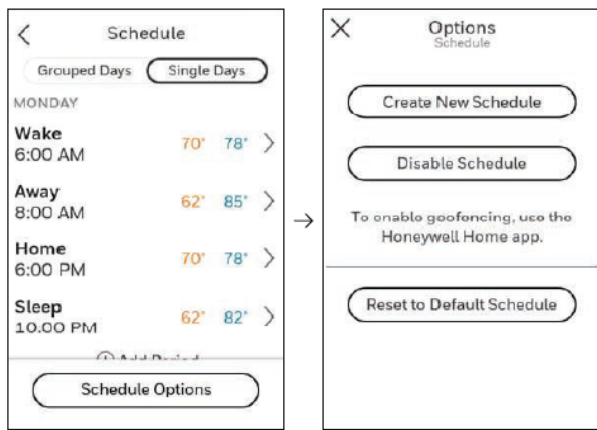

- Touch **Time** to edit the time for that schedule period.
- Touch **Priority** to select which sensors will be used for that period.
- Touch **Temperature** to set the Heat and Cool setpoints for that period.
- Touch **Fan** to select Fan **On**, **Auto**, or **Circ** for that period.

NOTE: To utilize Geofencing, set the schedule through the app.

Scheduling Through the App

Flexible scheduling: You can choose to use location-based temperature control (geofence/Auto Away technology), time-based scheduling, or use a combination of both to make sure your home is always comfortable.

- **Location-based temperature control:** Using geofencing/Auto Away technology, the T10/T10+ Smart thermostat will automatically use your smartphone's location, which can save energy when you leave and make your home comfortable by the time you return.
- **Smart scheduling:** Adds a Sleep period to location-based temperature control.
- **Time-based scheduling:** You can program a schedule where every day is different, a schedule where weekdays and weekends are different, or a schedule where every day is the same. There are four adjustable periods per day: Wake, Away, Home, and Sleep.
- **No schedule:** You can also choose not to set a schedule and adjust the thermostat manually.
- **Sensor Priority:** Select which sensors are used for each program period or when used manually.

1. In the app, select the thermostat you wish to schedule. Then scroll down and select Schedule.
2. Select **Grouped Days** for all days the same or Single day if you want some days to be scheduled different than others.

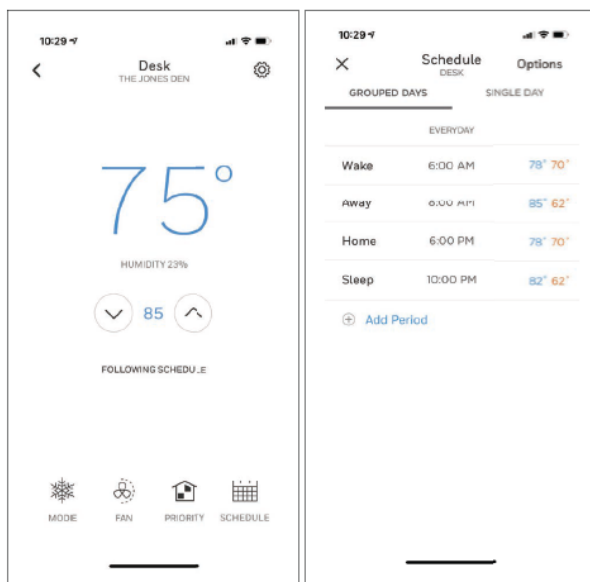

3. Select **Options** to turn schedule off, create a new time-based schedule, or switch to Geofencing/Auto Away.
4. Set priority sensor(s) for each program:

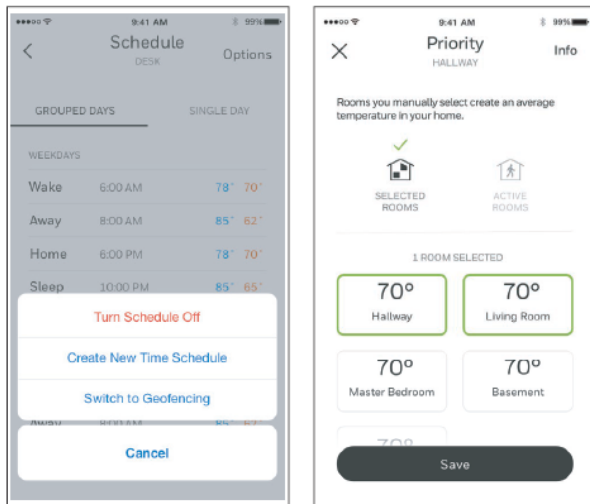

Location-Based Scheduling

When location-based temperature control is used, the thermostat active home screen display will show **Using Home settings**, **Using Away settings**, or **Using Sleep settings** below the room temperature.

If you set an additional Sleep period in the app, you'll also see the Following Schedule in the upper left corner of the thermostat screen.

If you manually change the temperature when location-based temperature control is active, the new temperature will remain in effect until you cross the geofence.

To adjust the geofence boundary, follow the steps below.

1. Open the app, tap the **MENU** icon in the upper left corner and then tap Geofence or "Auto Away" and enable this.
2. Tap **Geofence Radius**, and when the map and current geofence appear, touch, hold and drag the black dot to adjust the geofence boundary.
3. Tap **SAVE** to finish.



Schedule Override on Device

With thermostat in Heat, Cool, Auto, or Em Heat mode, press the up or down arrow to change the setpoint. (if thermostat is in auto mode, you need to press **Heat to** or **Cool to** first).

If scheduling is enabled it will say **Hold until** and show a time at the bottom of the screen. Touch this.

Display says **Use current temperature, fan, and comfort priority settings until...**

Options are:

- Next Period
- A Specific Time

- Permanently
- Remove hold

Choose the appropriate option. If you chose **A Specific time**, select the time you want to hold to. Press **Done** to return to Home screen.

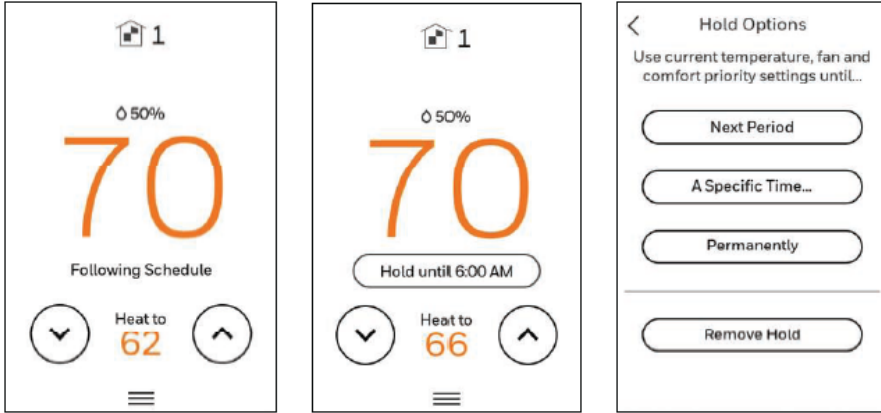

MAIN MENU

From Home Screen, press the **Menu** icon at bottom of the display (3 horizontal lines). (If this is not shown at home screen, touch screen to wake display first).

Main Menu Options

Notifications

Only displayed when there are active alerts/notifications. select "Notifications" to see details.

System Mode

(Available modes vary depending on how the thermostat was configured)

- Heat
- Off
- Cool
- Auto (see "[Auto Changeover Operation](#)" on page 101)
- Em Heat (see "[Em Heat and Auxiliary Heat Operation](#)" on page 101)

Fan

(Fan setting not available for all system types)

- Auto (Fan only runs with a call for Heat or Cool, or if set to run with Hum, Dehum, or Vent call)
- On (fan runs continuously)
- Circulate (fan runs randomly approx. 33% of the time)

For 2-pipe and 4-pipe fan coil applications, there *may* be settings for auto or high, medium and low fan speeds.

Priority

If wireless indoor temperature/humidity/motion sensors are used, select which sensors are used for temperature control. Choose Active Sensor (those detecting motion) or manually select which sensors to use.

Schedule

- Create new schedule – (Set a time-based schedule)
- Disable schedule
- Reset to default Schedule

NOTE: To enable Geofencing, use the Resideo app.

Weather

Shown if connected to WiFi and the app, & ISU 1060 = Internet, displays weather forecast for up to 10 hours in 2 hour increments.

Temperatures

Shown if configured for a floor/slab sensor in ISU 1055. Shows the temperature reading and settings for Floor sensor (T10+ only).

Humidification

- View current indoor humidity level & setting
- View humidifier status (humidifying, idle, off)
- Change humidity setting
- Options change mode, change window protection setting

Dehumidification

- View current indoor Dehumidity level & setting
- View dehumidifier status (dehumidifying, idle, off)
- Change Dehumidity setting
- Options change mode, adjust high speed fan priority setting

Ventilation

- View or change mode (Auto, On, Off)
- Timed ventilation 180 minutes max
- Options lockout settings for Sleep, High Outdoor Temperature, Low Outdoor Temperature, High Outdoor Dew Point

If ISU 10005 = VNT5070E1000, VNT5200E1000, VNT5150E2000, VNT5150H2000, VNT5200E2000 or VNT5200H2000, the ventilation menu will show the CFM and wattage of the ventilator while ventilator is running.

Temperature balancing (T10+ only). Shown if ISU 3310 is enabled.

- Auto or Off.

When set to auto, you can adjust the Room delta setting from .5°F to 10°F in .5°F increments (.25°C to 5°C in .25°C increments). This will allow the T10+ to run the fan if the temperature between sensors selected under “options” in the Temperature balancing menu.

Management

Devices & Sensors

- Add a wireless indoor or outdoor sensor
- Identify a wireless indoor or outdoor sensor
- Thermostat:
 - Temperature & humidity readings
 - and network name
 - IPV54 address
 - Change room name
- Equipment Interface Module:
 - Firmware version
 - Wireless signal strength
- Indoor Air Sensor:
 - Firmware version
 - Battery strength
 - Wireless signal strength
 - Temperature and Humidity readings
 - Occupied or unoccupied (detection of motion in room)
- Options:
 - Rename sensor (select Room name)
 - Use motion (Allows you to choose not to allow motion to be used from a one or more sensors when “active rooms” is selected in the priority menu.
 - Motion Sensitivity (HIGH = Triggered when very little motion is detected, MEDIUM = triggered when a moderate amount of motion is detected, LOW = triggered only when a lot of motion is detected).
 - Delete (Removes that sensor from the thermostat).
 - Blink lights (Will make the light on the indoor sensor you selected blink to help identify which sensor is matched with each name in the sensor menu.)
- Outdoor Air Sensor:
 - Firmware version
 - Battery strength
 - Wireless signal strength
 - Temperature and Humidity readings
 - Delete (this option is only shown in the "Devices & Sensors" menu when accessed via "Installer Options" menu).

Thermostat Information

- Mac Address
- IP Address
- Date Code
- Model Number
- Build Date
- Collection Version
- WiFi Bootloader Version
- WiFi Application Version
- RedLINK Application Version
- T10+ will show a QR code if you scroll down

Equipment Status

- System mode
- Heat stages (on or off)
- Cool stages (on or off)
- Fan on or off
- IAQ (Hum, Dehum, or Vent) on or off

Dehumidification Away Mode

If ISU 9180 is set for dehumidification away mode, then this menu displays the dehumidification Away mode status and settings.

Dealer Information

- Model number
- Date code
- Dealer company name and contact information if provided by installer. (See "Installer Options Menu" on the next page.)

Configuration

- WiFi
- Connect App
- Connect HomeKit
- Security
- Preferences
- Installer Options (See "Installer Options Menu" on the next page.)

Temperature balancing (T10+ model only)

If at least one wireless sensor is used, and ISU 3300 is enabled, the temperature balancing feature will run the system fan if the selected rooms have a temperature variation that exceeds the delta setting in ISU 3310.

When this feature is enabled you can select "Temperature balancing" under menu and select auto or off. When auto is selected you can:

- Adjust the Room Delta setting (number of degrees difference between the selected sensors required to energize the system fan)
- Open the options menu and select the sensors used or disable this feature during the sleep period.

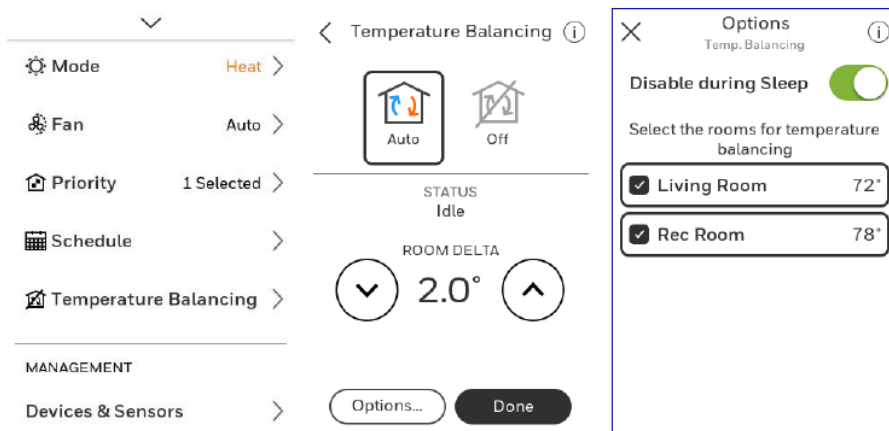

INSTALLER OPTIONS

To access the Installer options menu:

1. Touch the **Menu** icon (3 horizontal lines at bottom of display)
2. Scroll down and touch **Thermostat Information**.
3. Write down the date code from that screen. Then touch the left arrow at top of display to go to previous screen.
4. Scroll down until “Installer Options” is shown. Touch **Installer Options** and enter date code.

How to find more options

1. Touch the **Menu** button.
2. Scroll up and down for more options.

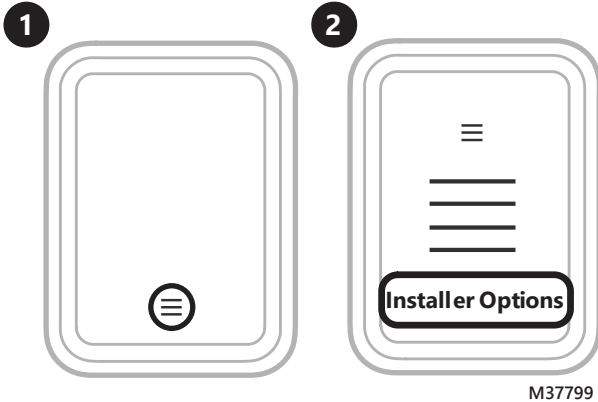

Installer Options Menu

Installer Setup

Setup thermostat.

Installer Test

- Turn on or off Heat stages
- Turn on or off Cool stages
- Turn on or off Em Heat stage
- Turn on or off IAQ equipment
- See equipment Run Time
- See the sensor temperature reading if a 10K/20K pipe sensor is used for a Fan Coil Unit

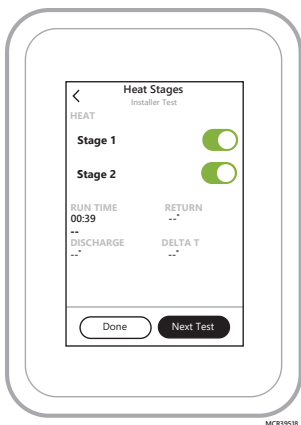

If discharge and return sensors (RATS & DATS) are used with T10+ and EIM, the display shows these readings and the delta during installer test.

Dealer Information Setup

Enter installer company name, phone number, website, and email. This allows the contractor's contact information to be displayed if the customer receives an alert or reminder.

Devices & Sensors

- Add a wireless indoor or outdoor sensor
- Identify a wireless indoor or outdoor sensor

Thermostat:

- Temperature & humidity readings
- Network name
- IPV54 address
- Change room name

Equipment Interface Module:

- Firmware version
- Wireless signal strength

Indoor Air Sensor:

- Firmware version
- Battery strength
- Wireless signal strength
- Temperature and Humidity readings
- Occupied or unoccupied (detection of motion in room)

Options:

- **Rename sensor** (select Room name)
- **Use Motion** (Offers the option of **not using** motion sensing from one or more sensors when Active Rooms is selected in the priority menu.)
- **Motion Sensitivity** (HIGH = Triggered when very little motion is detected, MEDIUM = triggered when a moderate amount of motion is detected, LOW = triggered only when a lot of motion is detected).
- **Delete** (Removes that sensor from the thermostat).
- **Blink lights** (Will make the light on the indoor sensor you selected blink to help identify which sensor is matched with each name in the sensor menu.)

Outdoor Air Sensor:

- Firmware version
- Battery strength
- Wireless signal strength
- Temperature and Humidity readings
- Delete (option only shown in the "Devices & Sensors" menu when accessed via "Installer options" menu).

Thermostat Information

- MAC Address
- Date Code
- Model number
- Build date
- Collection Version
- Bootloader Version
- Application Version
- WiFi Bootloader Version
- WiFi Application Version
- RedLINK Application Version

Reset

- Reset Schedule
- Delete all sensors
- Reset HomeKit
- Factory Reset
- Reset WiFi?

GETTING THE MOST FROM THE T10 OR T10+ SMART THERMOSTAT

Prioritize Rooms

Prioritize a specific room or multiple rooms, or let comfort follow your move using built-in motion detection.

Control on the Go

Adjust your thermostat from anywhere using your tablet or smartphone.

Save Energy

With Auto Away/Geofencing, you can save money on the most expensive part of your energy bill while you're away.

Simple Installation

The thermostat automatically programs itself. Just answer a few simple questions and you'll be up and running in no time.

Whole-Home Range

With a 200-foot range, 20 sensors with temperature, humidity, and occupancy detection can connect to your thermostat from throughout your home.

Know Your Home Is Safe

Get customizable alerts on your mobile device when the basement is so cold a pipe could burst, or if the baby's room is getting too hot.

Apple® HomeKit™ Setup

1. Touch **Menu** icon at the bottom of the T10 or T10+ home screen.

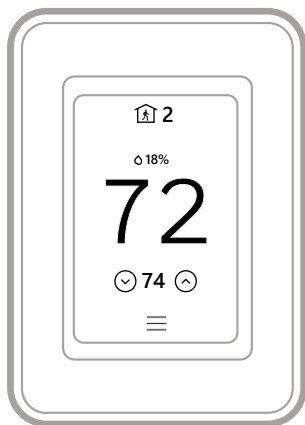

M39090

2. Scroll down and select **Connect HomeKit**.

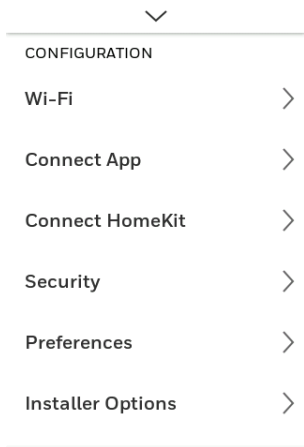

- 3. Use the Apple Home App and select Add Accessory. Scan the code shown on your thermostat with your phone.
- 4. Follow the instructions on your phone.

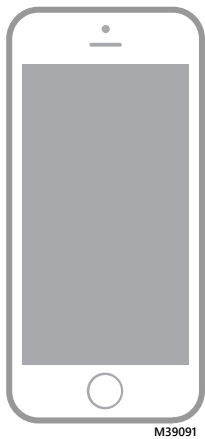

Note: We would recommend registering the thermostat to the First Alert or Resideo app when using Apple HomeKit to better sync the time.

Using Your Thermostat

The screen will wake up by pressing the center area of the displayed temperature.

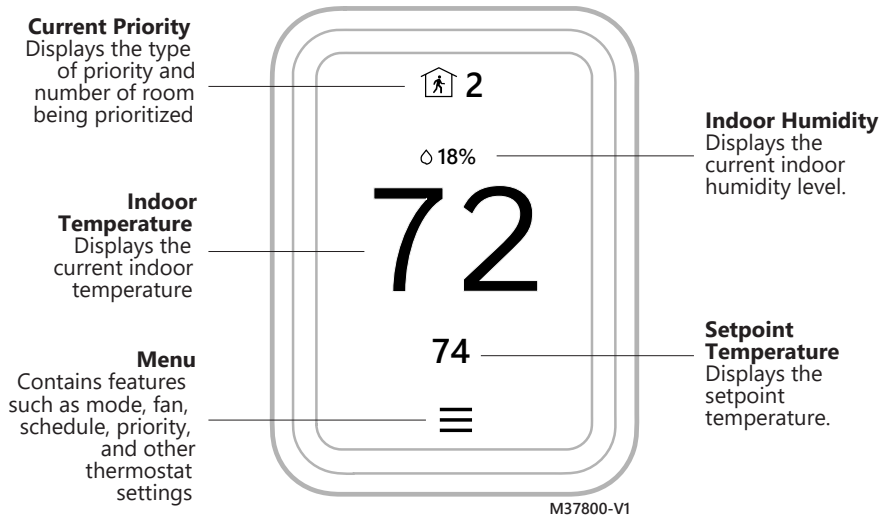

Setting the Time/Date

When the thermostat is linked to the home WiFi router and registered to an account using the First Alert or Resideo app, the date and time will update automatically.

If not using WiFi you can set the time/date as follows:

1. Touch **Menu**.
2. Scroll down and select **Preferences**.
3. Select **Date and Time**.
4. Date and time information are displayed.

Set Date

- If the date shown is incorrect, touch **Date**.
- Scroll up or down on the left of the display until the correct month is in the middle of screen.
- Scroll up or down on the center of the display until the correct day is in the middle of screen.
- Scroll up or down on the right of the display until the correct year is in the middle of screen.
- Touch **Done**.

Set Time

- If the time shown is incorrect, touch **Time**.
- Scroll up or down on the left of the display until the current hour is in the middle of screen.
- Scroll up or down on the center of the display until the current minutes are in the middle of screen.
- Scroll up or down on the right of the display until the correct am or pm is in the middle of screen.
- Touch **Done**.

Setting the Fan

NOTE: Fan setting not available for all system types.

- Touch **Menu**.
- Touch **Fan**.
- Choose on, auto, or circulate.
- Auto setting only runs the fan with the heating or cooling system.*
- On setting runs the fan continuously.
- Circ setting runs the fan approx 33% of the time to ensure air circulation.

* The fan may also run with the humidifier, dehumidifier, or ventilator depending on how the thermostat was configured.

Programming the Fan

You can set the fan to on, auto, or circ for each program when using time-based scheduling.

Setting the System Mode

- Touch **Menu**.
- Touch **System Mode**.
- Touch desired option.
 - Heat: Controls only the heating system.
 - Cool: Controls only the cooling system.
 - Off: Heating/cooling systems are off.
 - Auto: Selects heating or cooling depending on the indoor temperature.
 - Em Heat (heat pumps with backup Heat): Runs emergency heat on a heat call. Compressor is locked out.
- Touch **Done** to save and exit.

NOTE: The Auto and Em Heat system settings may not appear, depending on how your thermostat was set up.

Using Priority

Priority creates an average temperature in your home based on specific rooms. This allows you to prioritize comfort where you want it.

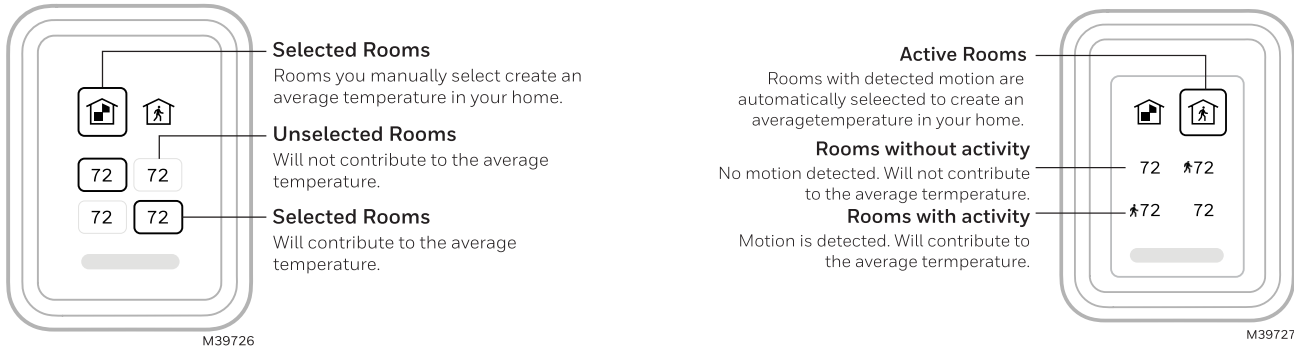

Selecting Sensors

The temperature reading displayed on the home screen is from the sensor or sensors that are being used for temperature control. You can change which sensors are being used for control by selecting menu-priority. From the home screen, touch the menu icon at the bottom of the display and select “Priority”.

Priority Screen

Selected Rooms

When set to “selected rooms” you may select one or more rooms to read the wireless indoor sensor information from. When multiple sensors are selected, the temperature is averaged.

Active Rooms

When set to “Active rooms” the thermostat controls temperature based on the reading from the indoor sensors that detect motion.

Alerts and Notifications

1. The red dot above the **Menu** icon indicates an active alert or notification. Touch the Menu icon to view active Alerts & Notifications.
2. Touch **Notifications** to open this menu.
3. Touch the alert message to see more information about the alert or notification.

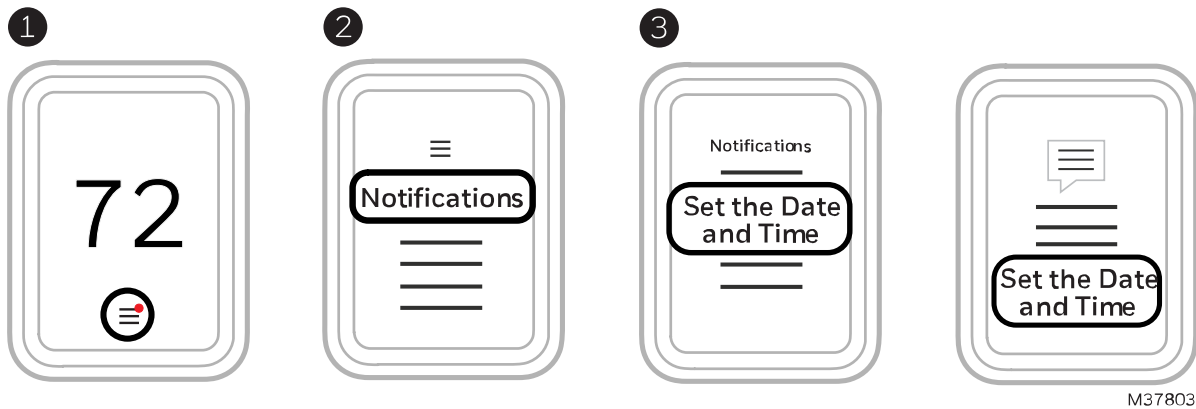

When there is an active alert or notification, you must select the notification banner and acknowledge the message before you are allowed to access the menu icon.

IAQ Reminders

You can set up IAQ reminders in the thermostat to remind users when filters, pads, bulbs, etc. need cleaning or replacement. The available reminders vary based on the ISU settings. For example, if the thermostat is configured to control a flow through humidifier, it will have the humidifier pad reminder but not the humidifier tank reminder:

- Air Filter 1
- Air Filter 2
- Electronic Air Cleaner Pre-Filter
- Electronic Air Cleaner Post-Filter
- Humidifier Tank/Water Filter
- Humidifier Pad
- Dehumidifier Filter
- Ventilator Core
- Ventilator Filter
- UV Bulb 1
- UV Bulb 2

Reminders that are displayed under preferences will change based on the IAQ equipment installed. Reminders for equipment that is already set up can be set using the steps below. Reminders for IAQ equipment that is not yet set up must be turned on from the installer setup.

NOTE: Air Filter, Humidifier Pad, Dehumidifier Filter, and Ventilator Filter are displayed under Preferences even if they have not been set up. Humidifier Pad is not displayed if a steam humidifier has been installed.

To access or adjust the reminder settings

- Select the **Menu** icon.
- Scroll down and select **Preferences**.
- Select the reminder you want to set from the list (shown above).
- Press ▲ or ▼ to set timer length. Ranges, increments and units will change based on the reminder.
- Press **Done** to save the reminder.
- Press **Reset Timer** when you have completed the recommended maintenance or you can extend the timer setting to turn off the alert and remind you later to do the recommended maintenance.
- Repeat these steps for all reminders you want to set

NOTE: When set for run time days, the thermostat tracks the amount of time the fan has run and compares that time against the number of run time days selected. Fan run time is counted when there is a call for forced air heating, cooling, or fan.

Setting Preferences

Preference menu options let you select how the thermostat displays information or responds to certain situations.

To access the Preferences menu:

- Touch **Menu**.
- Scroll down and select **Preferences**.
- Select an option and follow prompts:

Display

- Temperature units (Fahrenheit or Celsius)
- Language (English, French, or Spanish)
- Screen color (optional colors shown)
- Color behavior (Display color change to indicate Heat or Cool is running)
- Idle Screen Style (Temperature or Analog Clock)
- Backlight:
 - Active Backlight setting (50% to 100%)
 - Inactive Backlight setting (0% to 100%)
 - Inactive Night Backlight
- Brightness 0% to 100%
- Night start time
- Night end time
- Dark Idle theme (T10+ only. Display turns black during the Nighttime settings)

NOTE: The Night setting is different from the Scheduled sleep period

- App change behavior (When a temperature change is made by the app, would you like the thermostats to light up the display? Yes or No)
- Indoor display offsets (temperature and humidity)
- Bold font (Would you like the Home and idle screens to use a bold font?) **T10+ only**
- Clean screen (allows 30 seconds to clean the display without accidentally changing any settings)

Date and Time

- Set date
- Set time
- Set to 12 or 24 hour clock
- Set for Daylight Savings Time

Reminders (these vary based on ISU settings)

- Air Filter 1
- Air Filter 2
- Electronic Air Cleaner Pre-Filter
- Electronic Air Cleaner Post-Filter
- Humidifier Tank/Water Filter
- Humidifier Pad
- Dehumidifier Filter
- Ventilator Core
- Ventilator Filter
- UV Bulb 1
- UV Bulb 2

Adaptive Recovery

- On or Off

Fallback room (T10+ only)

- Can select thermostat or sensor(s)

After any changes, touch **Done** to save your settings.

Screen Color

The T10+ with **firmware version 03.03.08.02 or later** allows you to select the screen color from 12 different choices. Select **Menu > Preferences > Display > Screen Color**.

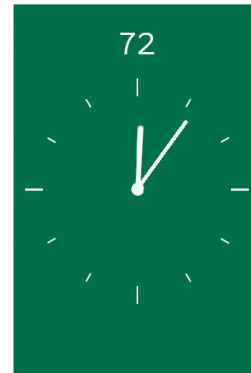
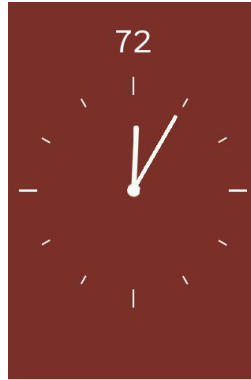
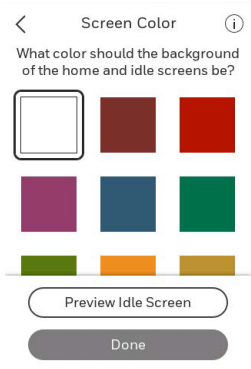

Screen color options

Inactive Night Backlight

There are two settings that can be used by customers who do not want the T10+ display to illuminate a dark room at night:

You can adjust the "Inactive Night Backlight Backlight" from 0% to 100%. At 0% the display is unlit and blank but wakes to 20% higher than that setting when someone touches the display.

If "Dark Idle Theme" is selected (T10+ models only), the display will show a black background. This is for customers who still want to read the display during the night setting time but don't want it to light up the room.

NOTE: When heat or cooling comes on, the display will still flood orange or blue. These colors are not as bright as the white idle screen but if the orange or blue is not desired, the customer can disable Dark Idle Theme and set the inactive backlight to 0%.

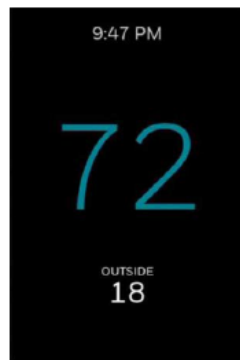
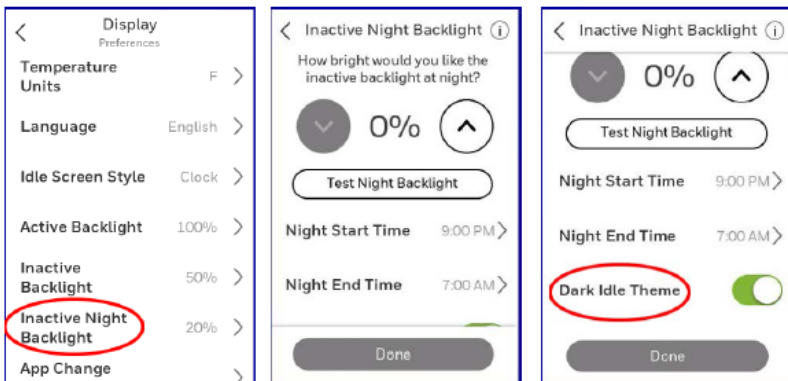

Fallback Room (T10+ only)

Under the preferences menu you can select which Room(s) are used if either:

- The T10+ is set for active rooms and none of the sensors detect activity.
- The selected sensors (active rooms or selected rooms) lose communication to T10+ (sensor failure, dead batteries, etc.)

If the fallback sensor(s) is also not communicating, the thermostat sensor will be used unless the installer had selected **“NEVER USE THERMOSTAT”**.

This operation differs between T10 and T10+. T10 always defaults to the thermostat in the situations above.

If you select “FALLBACK ROOM” then “OPTIONS”, you can select “NEVER USE THERMOSTAT”. This would be done if the thermostat was mounted in a utility room or other location that is not sensing the space temperature in an area it is controlling.

INDOOR AIR QUALITY CONTROL

Humidification

The thermostat reads the indoor humidity level and allows the user to set a humidification setting with or without window protection. The thermostat can be set up to control a humidifier in any system mode in the Installer Setup (ISU 8060).

Set up Humidification

1. Select the Humidifier Type at ISU 8000. Based on the humidifier type you select, the thermostat defaults to the most commonly used settings for that humidifier type. For example, a Bypass or Fan Powered humidifier will default ISU 8070 to "Hum when Heat is On."
A Steam humidifier will default ISU 8070 to "Tstat controls Fan."
2. Set Window Protection setting (ISU 8050).
Outdoor sensor temperature (Sensor or Internet weather) is required for Window Protection (ISU 1060).
3. Select the system mode(s) to allow humidification (ISU 8060). Options are Heat and off. Heat includes Heat, Emergency Heat and Auto. If the system is in Auto mode, the thermostat will allow humidification if the last call was for heat.
4. Select from one of the Humidification Control Options (ISU 8070).
 - Hum when Heat is On
 - The thermostat turns on the humidifier only if the heat is currently running and humidification is needed.
 - Hum when Fan is On
 - The thermostat turns on the humidifier only if the fan is currently running and humidification is needed.
 - Tstat Controls Fan
 - The thermostat turns on the humidifier and the fan when humidification is needed.
 - Hum Controls Fan
 - The thermostat turns on the humidifier when humidification is needed and the humidifier controls the fan.

Control Humidification Level

1. Touch **MENU** and select **Humidification**.
Touch **s** or **t** to select humidity level.
2. Touch **Done** to save your settings.
Touch **Cancel** to ignore changes.
3. If frost or condensation appears on the windows, press **MENU**, scroll down and select **options**. Then select **Window Protection Level**.

Window Protection

Window Protection limits the amount of humidity to prevent frost or condensation on windows. Window Protection (ISU 8050) requires either an outdoor sensor or use of Internet weather (Outdoor temperature setting In ISU chart).

The thermostat prevents frost or condensation on windows by not allowing the humidifier to run above a certain level. To prevent frost or condensation, the thermostat may turn off the humidifier before the humidity setting is reached.

If Window protection is enabled (ISU 8050), you can adjust this setting by pressing **MENU**, then scroll down and select **Humidification > Options > Window Protection Level**. Window Protection is set on a scale from 1-10. A setting of 10 represents poorly insulated windows and a setting of 1 represents well insulated windows. A higher number automatically reduces the humidity to help prevent frost or condensation on your windows. Use a lower number if indoor air seems too dry. To prevent frost/condensation on your windows during cold outdoor temperatures, poorly insulated windows require a higher Window Protection setting, which will limit how much your humidifier can run. After you set the Window Protection setting, check for frost/condensation on your windows in the morning. If frost/condensation is present, adjust the Window Protection setting to the next higher number and check for frost/condensation on your windows the next morning.

Continue to adjust the Window Protection setting to a higher number until frost/condensation is no longer present. If Window Protection is turned Off, the thermostat controls the humidity level to the user's desired humidity setting. Frost or condensation may appear on windows.

Dehumidification (Residential)

The thermostat reads the indoor humidity level and allows the user to set a dehumidification setting. The thermostat controls the humidity level using the cooling system or a whole house dehumidifier.

Dehumidification Using the Cooling System

When set for **A/C with Low Speed Fan**, **A/C with High Speed Fan** or **Reheat**, an **overcooling** limit can be set from 0 °F to 3 °F (ISU 9070). The thermostat uses the cooling system to reduce humidity by lowering the temperature as much as 3 °F below the current cool setpoint until the desired humidity level is reached.

If set for **A/C with Low Speed Fan**, configure the U contacts as **Normally Open** or **Normally Closed** (ISU 9050) and wire to the Low Speed Fan terminal on the equipment. For example, if the U contacts are normally closed, they will open when the thermostat calls for dehumidification.

If humidification and dehumidification are both set up to operate in the system mode (Off), the thermostat will automatically enforce a 15% deadband between the humidification and dehumidification settings. The thermostat will automatically switch between humidification and dehumidification to maintain the desired humidity level.

Dehumidification Overcooling Limit (ISU 9070):

This option uses the cooling system to lower the temperature up to 3° F below the current cool setpoint until the desired humidity is reached. The Dehum Over Cooling Limit range is from 0° to 3° F is set for low-speed fan and 1° to 3° F if set for high-speed fan.

Set up Dehumidification With Cooling System

Some screens shown in this section may not appear on the thermostat, depending on how you set up dehumidification.

1. Select the **Dehumidification Equipment** in ISU 9000.
2. Select whether the U terminals are Normally Open or Normally Closed (ISU 9050).
 - Normally Open – contacts are normally open and will close during a call for dehumidification
 - Normally Closed – contacts are normally closed and will open during a call for dehumidification.
3. Set the Overcooling Limit (ISU 9070).
Options:
 - 0 °F to 3 °F (A/C with Low Speed Fan)
 - 1 °F to 3 °F (A/C with High Speed Fan)

Dehumidification Fan Speed Priority (T10+ Only. See ISU 9005)

If the house has circulation issues to certain parts of the house when running in low speed, this feature will allow the thermostat to use the high speed fan more often so that the conditioned air has better circulation within the home.

- **Low Speed Fan with Cool Stage 1 Only:** When the thermostat is set to humidify with low speed fan, and humidity is high, and cooling is running at stage 1, always run with the low speed fan. When cooling goes to stage 2, it ramps up to high speed fan.
- **Low Speed Fan Always:** Regardless of which cooling stage is active, the thermostat will exclusively use the low speed fan when dehumidifying.
- **User Selectable:** The homeowner can set the high speed fan priority based on their comfort level (reachable via Menu > Dehumidification > Options > High speed fan)
If set to 10, the thermostat will always use the high speed fan and never switch into low speed mode operation. If set to 0, the thermostat will only use the low speed fan and never switch to the high speed fan when the humidity level is above the Dehumidity setting.

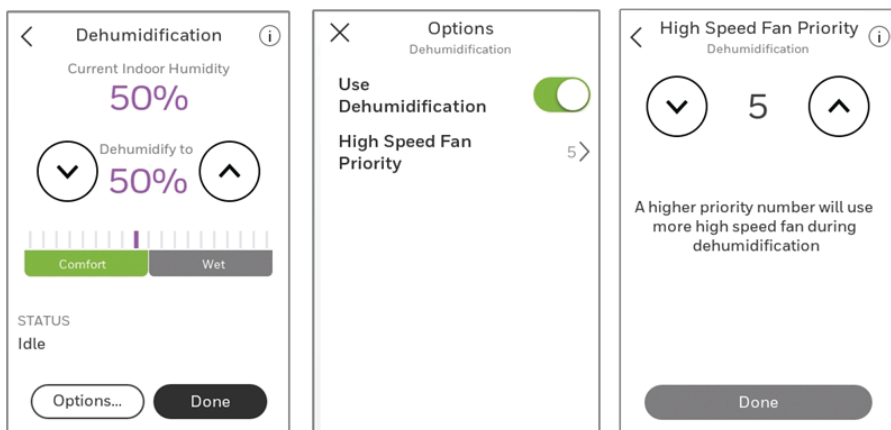

Dehumidification Using a Whole House Dehumidifier

The Whole House Dehumidifier option requires a dedicated unit for dehumidification. The thermostat can be set to control dehumidification in all modes (Heat, Off, Cool [ISU 9120]). Set up Dehumidification With Whole House Dehumidifier (Some screens shown in this section may not appear on the thermostat, depending on how you set up dehumidification.)

1. Select the Dehumidification Equipment in ISU 9000.
2. Select the system mode(s) to allow dehumidification ISU 9120.

NOTE: Heat includes Heat, Emergency Heat and Auto. If the system is in Auto mode, the thermostat will allow dehumidification if the last call was for heat.

Cool includes Cool and Auto. If the system is in Auto mode, the thermostat will allow dehumidification if the last call was for cool.

3. Set Dehumidifier Fan Control settings ISU 9130.
 - Tstat Controls Fan Thermostat turns on the dehumidifier and the fan when dehumidification is needed.
 - Equip Controls Fan Thermostat turns on the dehumidifier when dehumidification is needed. The fan is controlled by the equipment.
4. Set the desired lockout option. See ISU 9140.

Dehumidification Away Mode (T10+ Only)

See ISU settings 9180-9200.

Your system can be set to control indoor climate while your home is vacant during the humid season. If configured for Dehumidification Away Mode, before you leave, touch MENU, then select Dehumidification Away Mode. Temperature and humidity will be kept at levels that protect your home and possessions. When you return, touch Stop to resume normal operation.

Set up Dehumidification Away Mode

1. Select Allowed at ISU 9180.
2. Set Fan Control settings at ISU 9190.
 - **On:** Fan is always on.
 - **Automatic:** Fan runs only when cooling system is on.
 - **Circulate:** Fan runs about 35% of the Time.
3. Set temperature and dehumidification settings at ISU 9200
 - **Low Limit Temperature Setting** If the cooling system is used to control humidity while Dehumidification Away Mode is active, the thermostat allows the cooling system to lower the indoor air to the Low Limit Temperature Setting to reach the Dehumidification Setting.
 - **Temperature Setting**
The temperature maintained while Dehumidification Away Mode is active and the desired humidity level is satisfied.
 - **Dehumidification Setting**
The desired humidity level while Dehumidification Away Mode is active.

Control Dehumidification Level

1. Touch **MENU** and select Dehumidification.
2. Touch ▲ or ▼ to select Dehumidity level.
3. Touch options if you want to enable/disable the dehumidifier.

When disabled, the display will show off when viewing the dehumidifier setting screen.

4. Touch **Done** to save your settings.

NOTE: If your air conditioner is used to control humidity, the temperature may drop up to 3° F below your temperature setting until humidity reaches the desired level.

NOTE: If humidification and dehumidification are setup to operate in the same system mode (Off) the thermostat will automatically enforce a 15% deadband between the humidification and dehumidification settings. The thermostat will automatically switch between humidification and dehumidification to maintain the desired humidity level.

Dehumidification: Commercial (T10+ only)

The thermostat reads the indoor humidity level and allows the user to set a dehumidification setting. The thermostat controls the humidity level using the cooling system or a dehumidifier.

If humidification and dehumidification are set up to operate in the same system mode (Heat, Cool, Off) and you are sensing humidity from one location, the thermostat will automatically enforce a 15% deadband between the humidification and dehumidification settings. The thermostat will automatically switch between humidification and dehumidification to maintain the desired humidity level.

If humidification and dehumidification are set up to operate in the same system mode (Heat, Cool, Off) and you are sensing humidity from two different locations using a remote wireless indoor sensor (for example, main level and crawl space), the thermostat will allow humidification and dehumidification to operate at the same time, and there is no deadband between humidification and dehumidification settings.

Commercial Dehumidification Equipment Options: (ISU 9000)

- A/C with Low Speed Fan
- A/C with High Speed Fan
- Hot Gas Bypass
- Dehumidifier

NOTE - Hot Gas Bypass: During a call for dehumidification, the cooling capacity will be used to remove more latent heat than sensible heat. The operation of Hot Gas Bypass varies by equipment. For more details, contact the equipment manufacturer.

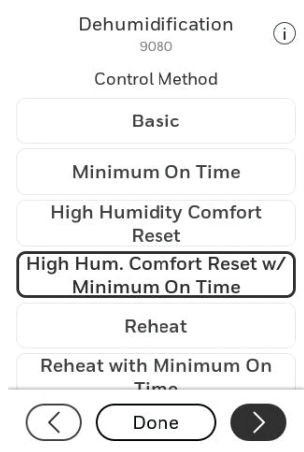

Basic: This option uses the cooling system to reach the desired humidity level. Minimum On Time, High Humidity Comfort Reset and Reheat are not used with this method. This setting is commonly used if your dehumidification equipment is Hot Gas Bypass.

Minimum On Time (ISU 9090): This option ensures that the compressor runs long enough to effectively reduce humidity when the cooling equipment is cycled on. The compressor will run for the minimum “on time” you set until the desired humidity level is reached.

High Humidity Comfort Reset (ISU 9100): This option uses the cooling system to lower the temperature up to 5° F below the current cool setpoint until the desired humidity is reached. The high humidity comfort range is from 1° to 5° F.

High Humidity Comfort Reset with Minimum On Time (ISU 9090 and 9100): This method uses both options above to reduce humidity while maintaining a comfortable temperature.

Reheat (ISU 9080): This option allows heating to run during dehumidification to help maintain a comfortable temperature. If only cooling stage 1 is used, during the “off” cycle, both cooling and heating run at the same time as needed to dehumidify without over-cooling. This option cannot be used in the Heat mode. This option is effective only if using a system with the A-Coil located before the heating coil (heat exchanger). This feature requires a conventional forced air heating system (gas, oil, or electric) in the application.

NOTES:

- Reheat can be used on heat pump applications that have a forced air backup heat source (gas, oil, or electric). The thermostat will turn on the first stage of Forced Air Backup Heat during Reheat.
- Reheat can be used on systems where the A-Coil is located after the heating coil (heat exchanger), but it is not effective at removing humidity.

Reheat with Minimum On Time (ISU 9080 and 9090): This method uses both Reheat and Minimum On Time options above to reach the desired humidity level.

If set for A/C with Low Speed Fan, configure the assigned set of U contacts as Normally Open or Normally Closed (ISU 9050) and wire to the Low Speed Fan terminal on the equipment. For example, if the U terminals are normally closed, it will open when the thermostat calls for dehumidification. See "[Wiring at T10 or T10+ without EIM](#)" on page 20.

NOTE:

The thermostat will not lower the fan speed when the second stage of cooling is on.

Ventilation

The thermostat can be set for the following ventilation types: (ISU 10000)

- ERV/HRV
- Passive (Fan Only)
- Fresh Air Damper

Ventilation Control Methods (ISU 10050)

Ventilation can be setup to meet either ASHRAE or Percent On Time settings. To meet these settings, the thermostat will ventilate during calls for Heat, Cool and Fan. If the required ventilation has not been achieved for ASHRAE or Percent On Time, the thermostat will force the ventilation equipment on.

ASHRAE

The thermostat operates ventilation equipment to meet the ASHRAE 62.2 ventilation standard based on CFM, number of bedrooms, and square footage of the house.

ASHRAE 62.2 can only be met if the ventilation equipment is running. If the ventilation equipment is off for any reason (outdoor ventilation lockouts, set up to turn Off during Sleep period, turned off by user, etc.), ASHRAE 62.2 is not met during those times. See ISU 10125 to select a Ventilation Priority.

Percent On Time

The thermostat operates ventilation equipment based on a percentage entered in the installer setup (ISU 10120). For example if Percent On Time is set to 50%, the ventilation equipment will run at random times during a 1 hour period until it reaches a 50% run time (approximately 30 minutes). Default setting is 30%. Range is 10% to 100% in 10% increments.

Ventilation Fan Control (ISU 10060)

- Tstat Controls Fan
 - The thermostat turns on the ventilator and the fan when ventilation is needed.
- Equip Controls Fan
 - The thermostat turns on the ventilator when ventilation is needed. The fan is controlled by the equipment.

Ventilation Priority (ISU 10125) Lockouts are Priority

The thermostat places a priority on lockouts versus the ASHRAE 62.2 ventilation standard. The thermostat will not run ventilation during the following lockout conditions (if configured) unless you manually call for ventilation:

- Lockout Ventilation during Outdoor Conditions (ISU 10130)
- Lockout Ventilation during "Sleep" program periods. This option is set by the user on the Ventilation screen. From Home press Menu > Ventilation > Options > Disable During Sleep.
- Turn on ventilation due to a custom Dry Contact Alert setting. This is if someone set ISU 6005 for a custom Dry Contact Alert and set ISU 10065 to turn on the ventilator.
- Lockout ventilation due to a custom Dry Contact Alert setting. This is if someone set ISU 6005 for a custom Dry Contact Alert and set ISU 10145 to lock out the ventilator.

Opposite actions cannot be selected for the same custom dry contact (Ex. user cannot select both to Turn Ventilation On and Lockout Ventilation for the Custom Dry Contact 1).

If opposite actions are triggered at the same time due to different custom dry contacts (example, Dry Contact Alert 1 set to turn on ventilator and custom dry contact 2 set to lock out ventilator), Lockout Ventilation has priority over Turn Ventilation On.

ASHRAE is Priority

ASHRAE requires additional ventilation following a long off cycle. The thermostat meets the ASHRAE 62.2 ventilation standard by running additional ventilation when outdoor conditions are favorable. If ASHRAE cannot be met when outdoor conditions are favorable, the thermostat will override the outdoor lockouts and run ventilation. When using this option, it is recommended to increase the rate (CFM) of the ventilation equipment to meet the ASHRAE 62.2 ventilation standard in a shorter run time.

NOTE:The ability to lock out ventilation during the "Sleep" program periods is not an option when you select ASHRAE is Priority.

Ventilation – Outdoor Condition Lockouts (ISU 10130)

Ventilation will not operate when outdoor conditions exceed the lockout settings unless you manually call for ventilation or Ventilation Priority (ISU 10125) is set to ASHRAE is Priority and ventilation is needed to meet ASHRAE. Lockouts can prevent ventilation during extreme weather conditions to keep humid, hot, and cold air out of the home.

NOTE: This feature requires outdoor sensor for outdoor temperature limits, or Internet connection for temperature and humidity lockouts.

Options are:

- Ventilation Low Temperature Lockout Setpoint (Off, -20° to 40° F)
- Ventilation High Temperature Lockout Setpoint (Off, 80° to 110° F)
- Ventilation High Dewpoint Lockout Setpoint (Off, 65° to 85° F)

Refer to the information below if you need assistance setting the High Dewpoint Lockout.

- Higher than 80: Extremely uncomfortable
- 75 to 80: Very uncomfortable
- 70 to 74: Quite uncomfortable
- 65 to 69: Somewhat uncomfortable
- Ventilate On High Indoor Humidity (ISU 10160)

If set to ventilate on high indoor humidity, the ventilator turns on to remove excess humidity if the indoor humidity is 10% above the humidification setting. The thermostat must be in the Heat mode to ventilate on high indoor humidity. If frost control is used, then the ventilation setting will adjust to stay approx. 10% RH above the humidity setting.

Control Ventilation Level

1. Touch **MENU**, and select Ventilation. You can check or change the ventilation mode.
Mode:

- **Auto:** Ventilation runs as programmed by the installer.
- **Off:** Ventilation remains off unless turned on using the timer.
- **On:** Ventilation is always on.

The display will show whether the ventilator is currently running under “status”. To temporarily turn the ventilator on, use the up arrow to set the number of minutes you want the ventilator to run (0-180 minutes). To cancel a temporary setting, press **Cancel Timed Ventilation**. **NOTE:** This setting is not available when ventilator is set to “on”.

2. Touch **Done** to save your settings. Touch **Cancel** to ignore changes.

Lockout During Sleep:

Under the ventilation menu, touch **Options**. Select or deselect **Disable During Sleep**. Touch the back arrow in upper left of display to return to previous screen.

ADVANCED FEATURES

Cleaning the Thermostat Screen

When you select the Clean Screen option, the screen is locked to prevent accidental changes to the thermostat while you clean the screen.

1. Touch **MENU**.
2. Scroll down and select **Preferences**.
3. Select **Display**.
4. Select **Clean Screen**.
A prompt asks if you want to clean the screen for 30 seconds.
5. Touch **Yes**. A countdown timer displays elapsed time until the screen is reactivated.

NOTE: Do NOT spray any liquid directly on the thermostat. Spray liquids onto cloth, then use the damp cloth to clean the screen. Use water or household glass cleaner. Avoid abrasive cleansers.

Adjusting Security Settings

You can adjust security options to prevent unauthorized changes to system settings.

1. Touch **MENU**.
2. Scroll down and select **Security**.
3. If you already know the password, select **Change Lock Mode**. If you don't know the password, select **Create Password**.

Lock mode options

- Unlocked: Full access allowed.
- Partially locked: Only temperature can be changed.
- Fully locked: No access allowed.

If you choose **Create Password** make sure to write it down for reference.

Dealer Information

This can be viewed by the homeowner when an alert or reminder message appears on the thermostat display. Entering Dealer Information

1. Touch **MENU**.
2. Scroll down and select **Dealer Information**. If this information has not previously been entered, note the date code from this screen.
3. Touch the back arrow in upper left of display.
4. Select **Installer Options**.
5. Enter date code.
6. Select **Dealer Information Setup**.
7. Click on each of the categories to enter the dealer information.
 - Company
 - Phone
 - Website
 - Email

Viewing Dealer Information

Check dealer information if you need to contact your installer for maintenance, repairs, or upgrades.

1. Touch **MENU**.
2. Scroll down and select **Dealer Information**.

NOTE: This menu option will only appear if the contractor had entered this information.

Caps Lock

When entering contractor information, customer Dry Contact Alert message, etc., double-click the Shift key to enter text all in upper-case:

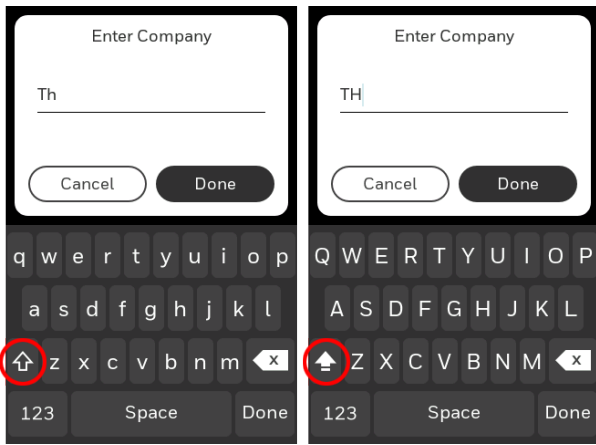

Auto Changeover Operation

Auto changeover is available if the thermostat is configured for at least 1 Heat stage and 1 Cool stage and ISU 3000 is set to “Auto”.

When configured this way, you can select “Auto” as one of the options under “System mode”.

ISU 3015 is the auto changeover differential setting. It can be set from 0–3 °F (0–2.5 °C). When in auto mode, the customer can always set the Heat and Cool setpoint to the same temperature, regardless of the differential setting although most customer prefer to have a cool setpoint that is at least 3 degrees above the Heat setpoint. When 0 is selected, we enforce a 1.5°F differential behind the scenes to ensure the heat doesn’t come on after cooling shuts off or vice-versa.

The differential is the minimum number of degrees the temperature needs to rise or fall before switching from Heat to Cool while in auto changeover mode. Example: With a differential of 3, if heat and cool were both set for 70, and heat had been used last, the temperature would need to rise at least 3 degrees above the heat setpoint before the thermostat would turn on cooling. Then it would run cooling down to setpoint and cycle cooling on and off to maintain setpoint. The temperature would then need to drop at least 3 degrees below the cool setpoint before heat could come on.

If the AC is used for dehumidification then we enforce an additional temp drop below the over-cooling amount, (ISU 9070) prior to switching back to heat.

Em Heat and Auxiliary Heat Operation

Auxiliary Heat:

Auxiliary Heat runs as backup to the heat pump. It runs with the heat pump when:

- The thermostat is set to Heat mode.
- The Backup Heat is set to electric (ISU 2180).
- Load conditions determine Backup Heat is needed.

The heat pump could be locked out when in Heat mode by the balance point setting (ISU 3120) or if the backup heat is gas or oil and backup heat differential (ISU 3090) or upstage timer (ISU 3110) are used.

Emergency Heat:

Emergency Heat runs when you manually switch the thermostat to the Em Heat mode. When the thermostat is in Emergency Heat mode, the heat pump is locked out.

Emergency Heat mode is only available when the thermostat is configured for a heat pump (ISU 2000) and Backup Heat stages is set to 1 (ISU 2071).

From the home screen touch the menu icon and then “System Mode”. You can set the thermostat to Heat, Off, Cool, Emergency Heat, or Auto. (Auto only available if ISU 3000 is set to Auto.)

When the thermostat is set to Em Heat mode, the heat pump is locked out and the Backup Heat is used to maintain the heat setpoint.

If ISU 2175 is set to “Drive aux and E together”, then with a call for emergency heat or auxiliary heat, both E and AUX terminals are energized. Typically the backup heat is wired to Aux and E is unused when set this way.

If ISU 2175 is set to “Aux and E independent”, then with a call for emergency heat, the E terminal is energized and the Aux terminal is not. The wire to Aux controls a heat source that runs as backup heat to the heat pump when the mode is set to “Heat”. The wire to E controls a heat source that runs independent of the heat pump when mode is set to Em Heat. In most cases, the heat pump uses the same heat source for auxiliary heat and em heat.

Dual fuel systems (Heat pump with gas or oil furnace backup) cannot run the heat pump and furnace at the same time.

Adaptive Intelligent Recovery

Over time, the T10 or T10+ thermostat learns how long it takes your system to reach your programmed temperature setting.

The thermostat turns on the heating/cooling system early and assures that the programmed temperature setting is reached at the programmed time regardless of weather conditions. For example, if the Wake program period is set to 6:00 am with a heat setting of 70 degrees, the heat will turn on before 6:00 am, so the temperature is 70 degrees at 6:00 am. The thermostat displays "In Recovery" when it turns the system on early.

Adaptive Intelligent Recovery[®] calculates the recovery ramp based on how far the room temperature is away from the temperature setting, previous equipment performance and weather history, allowing the thermostat to start recovery at the optimal time so it can reach the programmed temperature setting at the programmed time. The T10 or T10+ thermostat uses two recovery ramps when set up to control a heat pump system; one ramp for the compressor and one ramp for the auxiliary heat. Once the room temperature intersects the compressor ramp, the compressor turns on until the setpoint is reached. If the room temperature does not rise quickly enough and intersects the second ramp, the auxiliary heat turns on. It takes about one week for the thermostat to adjust to weather conditions, equipment performance and construction of the home. If the temperature setting is reached too early or too late, the ramp is adjusted for the next day's recovery. See figure below:

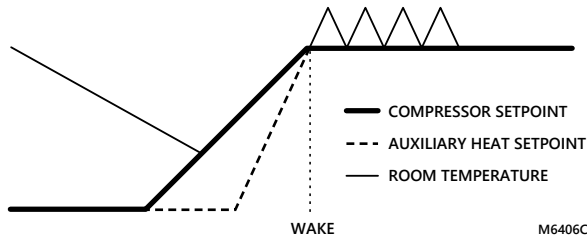

Compressor Protection

The thermostat keeps the compressor off for a few minutes before restarting, to prevent equipment damage. During this "off" time, the message **"Waiting for equipment"** is displayed on screen.

P + I Control

A conventional mechanical or electronic thermostat does not control temperature precisely at setpoint. Typically there is an offset (Differential) in the control point as the system load changes. Many factors contribute to offset including the switch differential, thermal lag, overshoot, cycle rates and system load.

The T10 or T10+ thermostat however, works much differently than a conventional mechanical or electronic thermostat when Differential is set to comfort. Differential is always set to comfort and not adjustable when controlling a 2 stage furnace or 2 stage heat pump without Aux Heat. The proprietary algorithm in the thermostat eliminates the factors causing offset (Differential). This makes temperature control more accurate than the conventional mechanical or electronic thermostat. The temperature control algorithm is called proportional plus integral (P + I) control.

The thermostat sensor or indoor sensor senses the current space temperature. The proportional error is calculated by comparing the sensed temperature to the setpoint temperature. The deviation from the setpoint is the proportional error.

The thermostat also determines integral error, which is a deviation based on the length of error time (how long the sensed room temperature has been away from the setpoint temperature). The sum of the two errors is the (P + I) error.

The cycle rate used to reach and maintain the setpoint temperature is computed using the P + I control algorithm. The addition of the integral error is what differentiates the thermostat from many other mechanical and electronic thermostats.

Heat Differential

For stage 2 of conventional systems or 2 stage heat pump without Aux Heat

The thermostat will use the stage of heating as needed to keep the indoor temperature within 1 °F (0.5 °C) degree of the setpoint. The thermostat turns on stage 2 when the capacity on stage 1 reaches 90%.

Heat pumps with electric Aux Heat when Differential is set to "Comfort"

The thermostat will use the stage of heating as needed to keep the indoor temperature within 1 °F (0.5 °C) degree of the setpoint. The thermostat turns on Aux Heat when the capacity on highest compressor stage has reaches 90%.

Heat pumps with electric Aux Heat when Differential is set to 2°F or higher(2 °F to 15 °F adjustable)

If the indoor temperature drops to the Differential amount while the highest compressor stage is running the thermostat will continue to run the heat pump stages and also energize the Aux Heat.

For example, if the Backup Heat Differential is set to 2 °F (1.0 °C), the indoor temperature must be 2 °F (1.0 °C) below the setpoint before the backup heat turns on. When a manual temperature change is made, there will typically be a delay before the thermostat brings on the backup heat, regardless of the upstage timer settings. When Differential is set to other than Comfort, the upstage timer and Holdoff timer settings are also available.

Dual Fuel heat pumps with gas or oil Backup Heat

If the thermostat is configured to control dual fuel, the Differential cannot be set to Comfort. It will default to 2 °F and can be adjusted from 2 °F to 15 °F.

If the indoor temperature drops to the Differential amount while the highest compressor stage is running the thermostat will end the call for the heat pump stages and run the fossil fuel heat stage.

For example, if the Backup Heat Differential is set to 2 °F (1.0 °C), the indoor temperature must be 2 °F (1.0 °C) below the setpoint before the thermostat will shut down the heat pump and run the fossil fuel heat.

When a manual temperature change is made, there will typically be a delay before the thermostat brings on the Backup Heat, regardless of the upstage timer settings.

Upstage Timer

The **Upstage** timer setting is only available when:

- The thermostat is configured for a heat pump with an aux heat stage (electric or fossil fuel).
- The Differential setting is set to a setting other than “Comfort” (2 °F to 15 °F).

Backup Heat **Upstage** Timer options are Off, 30 minutes to 16 hours. Default is Off.

The upstage timer allows* the Aux Heat to run when the highest heat pump stage has run for longer than the timer setting during a steady state condition. Steady state means the thermostat is cycling to maintain setpoint.

Manually raising the setpoint or a scheduled setpoint change will not trigger the upstage timer. In those conditions the thermostat will not use Backup Heat unless a different condition triggers the thermostat to run the Backup Heat (Differential, balance point, or manually switching the thermostat to Em Heat mode).

**Differential and upstage timer are designed to restrict the auxiliary heat for customers who are energy conscious. The aux heat does not necessarily run after the timer has expired even in a steady state condition. Once the timer expires in steady state the thermostat calculates whether or not to run the aux heat based on the load capacity of the highest heat pump stage.*

If the heat pump struggles to maintain setpoint, we would suggest one of the following steps:

1. Verify the heat pump is operating as expected.
2. Set a balance point. If a balance point is already used but the heat pump cannot handle the load even when operating correctly, the installer may need to raise this setting.
3. For heat pump with electric backup heat, set the Differential to “Comfort”, this uses the backup heat more aggressively.

Holdoff Timer

The Backup Heat **Holdoff** Timer is available for any system with 2 heating types, the Backup Heat Differential is set to 2 °F (1.0 °C) or higher, and backup heat upstage timer is set to 30 minutes or more. Unlike the upstage timer, the holdoff timer can be activated by a temperature set point change (not limited to steady state). The holdoff timer starts when the highest stage of the previous equipment type turns on. The out-of-box setting is “Auto” and the thermostat will hold off the use of backup heat as long as possible when the set point is changed. If this is changed to a setting other than Auto, then the auxiliary heat will be FORCED to turn on after this time is met.

Programmed Recovery

If the primary heat is making progress as expected, backup heat will not be used to reach the setpoint of the next program period. Backup heat is always restricted during a programmed recovery when the Adaptive Intelligent Recovery feature is used. See note below.

NOTE: During a programmed recovery (or when the temperature setpoint is changed by the user), the thermostat waits to turn on the backup heat depending on system performance, load conditions and how many degrees the temperature setpoint is changed. Backup heat will be used ONLY when the temperature is not rising quickly enough to reach the setpoint in a reasonable time. Upstage timer for heat pump with aux heat applications is only used in steady state (cycling to maintain setpoint). The thermostat will not run the aux heat during a programmed recovery unless one of the following conditions occurs:

1. Differential is set for comfort and thermostat calculates that the heat pump cannot effectively handle the load conditions.
2. Differential is set to 2 °F to 15 °F and indoor temperature drops while the highest stage of heat pump is running.
3. Outdoor temperature drops below the balance point setting (if used).
4. Thermostat is manually switched to em heat mode.

Finish with High Heat stage and/or Finish with High Cool stage

These settings allow the installer to keep the high stage of the equipment running until the desired setpoint is reached. This setting is recommended for Geothermal Heat Pumps to allow the loop to rest.

When set to no (default), the thermostat cycles the stages based on load conditions and the cycle rate setting for these stages.

“Finish with High Cool Stage” is ISU 3020.

“Finish with High Heat Stage” is ISU 3021.

Set to **Yes** to turn on these features. The default is No.

Heat Pump and Backup Heat Lockout Operation

Heat pump with outdoor temperature lockouts

Outdoor temperature lockouts are optional. See Installer Setup options (ISU 3120).

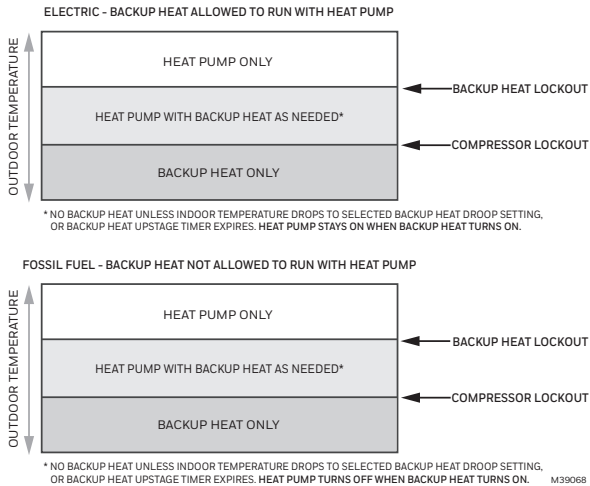

Fan Coil Unit Settings and Operation

Fan Coil Unit Settings

T10+ thermostats with the latest firmware can be configured to control a 2-pipe fan coil or a 4-pipe fan coil. Prior to that, T10 & T10+ models could support a hot water fan coil (used for heat only).

Hot water fan coil - (Supported by all models of T10 & T10+) A hot water fan coil requires that the thermostat energize W to move hot water through a coil that is inside the HVAC supply ducting and then turn on the blower fan to blow air over the hot coil and deliver it to the space. All T10 & T10+ thermostats have a setting for this. The T10 or T10+ energizes a single blower speed, wired to G for these systems.

4-pipe fan coil - (Supported by T10+ with firmware 03.03.08.02 or later and EIM [if used] with firmware 01.02.01.00 or later) A 4-pipe fan coil requires that the thermostat energize W to move hot water through a hot water coil or energize Y to move cold water through a cold water coil. Then the thermostat turns on the blower fan to blow air over the hot coil and deliver it to the space. Most 4-pipe fan coil units have multiple fan speeds. The low speed fan is wired to G. The medium speed fan is wired to Y2. The high speed fan (if used) is wired to U. There are other special fan coil unit settings which can vary for different systems. These settings are covered in the Fan Coil Unit section.

2-pipe fan coil - (Supported by T10+ with firmware 03.03.08.02 or later and EIM [if used] with firmware 01.02.01.00 or later) A 2-pipe fan coil energizes the same terminal (Y) to move hot water through a coil as it does to move cold water through a coil. Therefore, a thermostat that controls a 2-pipe fan coil needs to know whether the pipe is hot or cold. When it senses that the pipe is hot, the T10+ automatically switches to heat mode. When it senses that the pipe is cold, the T10+ automatically switches to cool mode. If there is an emergency heat stage, the user can manually switch the thermostat to emergency heat mode when the pipe temperature is below the heat threshold setting. In that case, the T10+ energizes the Aux to run the backup heat.

The T10+ has different options for how to perform the changeover from heat to cool based on pipe temperature.

- The T10+ can be used with a 10K or 20K sensor
- The T10+ can be used with a dry contact switch (such as an aquastat) to switch from heat mode to cool mode based on pipe temperature. The wiring diagrams for the fan coil unit section show how to wire the dry contact switch or wired sensor for this purpose. The ISU section shows the configuration settings.

When running heat or cooling, the T10+ turns on the blower fan to blow air over the coil and deliver the conditioned air to the space. Most 2-pipe fan coil units have multiple fan speeds. The low speed fan is wired to **G**. The medium speed fan is wired to **Y2**. The high speed fan (if used) is wired to **U**. There are other special fan coil unit settings which can vary for different systems. These settings are covered in the **Fan Coil Unit** section.

Fan Sequence Operations

(ISU 2105, 2106, 2107)

ISUs 2105 – 2107 are used to select the number of fan speeds controlled on a fan coil unit system and assign (or be instructed) where these speeds are wired to.

(ISU 3320)

ISU 3320 allows the installer to select how the fan speed is controlled when the T10+ is controlling a fan coil unit with multiple fan speeds. The options are **Auto**, **Multiple Speeds**, or **All Allowed**. When ISU 3320 is set for Auto, the T10+ uses the fan ramping algorithm to control the fan speed with a call for heat or cooling. The fan will be off with no call for heat or cooling. If ISU 3320 is set to Multiple Speeds, the user may select Lo, Med, or Hi from the fan menu. The thermostat will continuously run at the speed selected. If ISU 3320 is set to All Allowed, the user may select Auto, Lo, Med, or Hi from the fan menu. When Auto is selected, the fan runs only during heat or cool calls and the fan speed at which it runs is based on the control algorithm. If set to Lo, Med, or Hi, it will continuously run at the speed selected both in Idle and with a call for Heat or Cool.

(ISU 3325)

ISU 3325 allows the installer to select whether the fan always starts at the highest speed when there is a call for Heat or Cool. Some systems require this to ensure that the fan starts correctly. If enabled, the fan will start at the highest speed. If set to a speed other than High, the thermostat will then reduce the fan speed to the one selected in the fan settings or control to the correct speed based on the control algorithm if it is set to AUTO.

(ISU 3340)

ISU 3340 allows the installer to select whether the fan will reset to the Auto mode after a time delay when the user makes the setting Lo, Med, or Hi. The options are **Off**, **2 hours** or **4 hours**. If set to Off, the T10+ will run at the fan speed selected by the user indefinitely until the fan speed is changed manually.

(ISU 4010)

ISU 4010 allows the installer to determine if a pre-occupancy purge is used. This option applies to any light commercial application that has a fan and is using a schedule. This setting determines if the fan should run prior to the Occupied schedule, and if so how far in advance. If a system with multiple fan speeds is used, this option will run the fan at the highest speed during this time.

Remote Setback (Occupancy Setback / Occupancy Sensor)

The T10+ thermostat allows you to use **Remote Setback** (sometimes referred to as **Occupancy sensing** or **Occupancy setback**). This energy-saving feature can be enabled using one or more **C7189R3002** wireless indoor sensors, or with an occupancy sensor that opens or closes a dry-contact switch.

During occupied periods, the sensor tells the thermostat to switch to STANDBY (Setback settings) when no one is in the room. If someone is in the room, the sensor follows the settings of the Occupied period. The occupancy sensor is ignored during unoccupied periods. If someone is in the room, the sensor follows the schedule settings set by the installer or a manual override setting (if not locked out by installer/property manager).

To use the feature for energy savings when a room is unoccupied, but no regular Occupied schedule has been set:

The installer can access the Schedule menu and disable any scheduled period except **Occupied 1 (Commercial)** or **Wake (Residential)**. In this way, the thermostat will have an Occupied schedule setting to which it can default when occupancy is detected.

ISU settings 2240, 6020, 6030 & 6040 are related to occupancy sensing. If an occupancy sensor opens or closes a switch when occupancy is detected, that switch is wired to **R** at HVAC and **L** at T10+ when an EIM is not used. If an EIM is used, the switch is wired to S1, S2, S3, or S4 terminals.

A Remote Setback Time Delay (ISU 6030) can be set to force the thermostat to wait before it switches from occupied settings to the standby settings. This allows the room to stay comfortable if the room is unoccupied for a short period of time. When set to 0 minutes, the thermostat will switch from occupied settings to the standby settings immediately when the room is unoccupied.

Hotel Card Reader:

Some Fan Coil Unit thermostats used in hotels use a remote setback triggered by a room key card holder. If the guest inserts the key card into the holder while in the room, the thermostat will switch to Occupied temperature settings. When using an EIM, the wires from the card reader go to the S contacts on the EIM, (the same as on a TB7100 thermostat). If the EIM is not used, one of these wires goes to R at HVAC and the other wire goes to L at thermostat/UWP. See the wiring diagrams.

Set Up Remote Setback

1. Select a remote setback option in ISU 2240 (see Figure below). C7189R3002 wireless indoor sensors have a built-in motion sensor. The “Dry Contact” or “L Terminal” settings require an external occupancy sensor which opens or closes a switch when occupancy is detected.

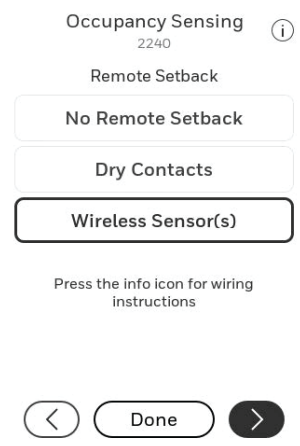

Options when EIM is used.

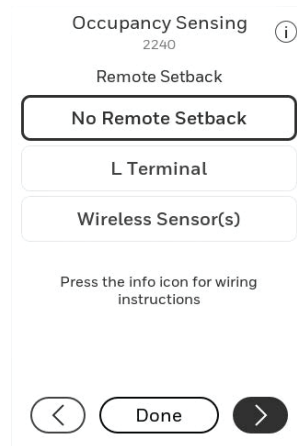

Options when EIM is not used.

2. If a dry contact is used to initiate Remote Setback and an EIM is used, **6010** is used to assign the Occupancy Sensor to a set of **S contacts** on the EIM.

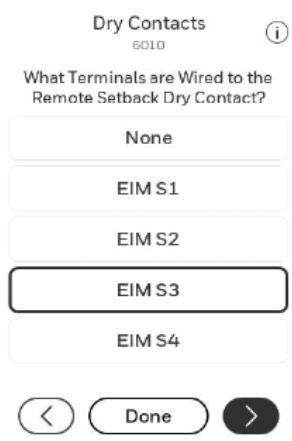

3. The setting below is shown if either **Dry Contacts** or **L Terminal** is selected for 2240. Select **Normally Open when Occupied** or **Normally Closed when Occupied**, based on the type of dry contact device installed.

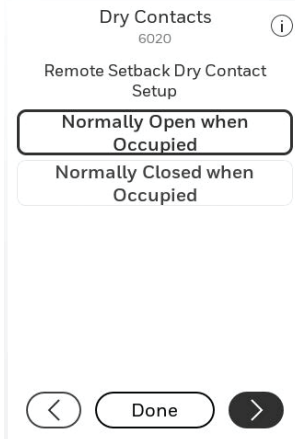

NOTES:

- **Normally Open when Occupied:** The Dry Contact device is open when the room is occupied and will close when the room is unoccupied.
 - **Normally Closed when Occupied:** The Dry Contact device is closed when the room is occupied and will open when the room is unoccupied.
4. ISU 6030 is shown unless **No Remote Setback** is selected for ISU 2240. Select a Remote Setback **Time Delay** (See Figure below). The Remote Setback Time Delay forces the thermostat to wait before switching from Occupied settings to the Standby settings. When set to 0 minutes, the thermostat will switch from settings to the Standby settings immediately when the room is unoccupied.

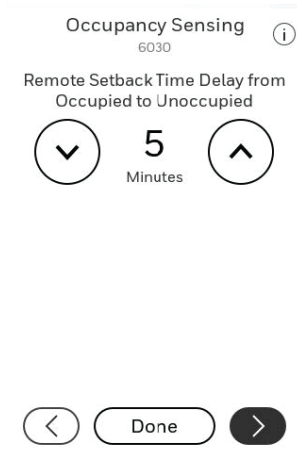

5. Select the Standby settings that you wish to maintain when the occupancy sensor detects that the room is unoccupied.

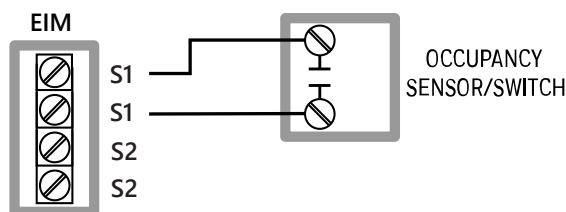
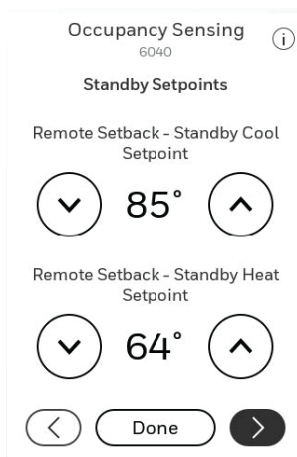

NOTE: OCCUPANCY SENSOR/SWITCH CAN BE WIRED TO ANY OF THE 4 SETS OF S ON EIM (S1, S2, S3, S4).
 CONFIGURE ISU SETTINGS 2240, 6010, 6020, 6030, AND 6040 ON THE T10+ FOR REMOTE SETBACK. M39613

Figure 83: Remote Setback using a Dry contact switch on a T10 with EIM

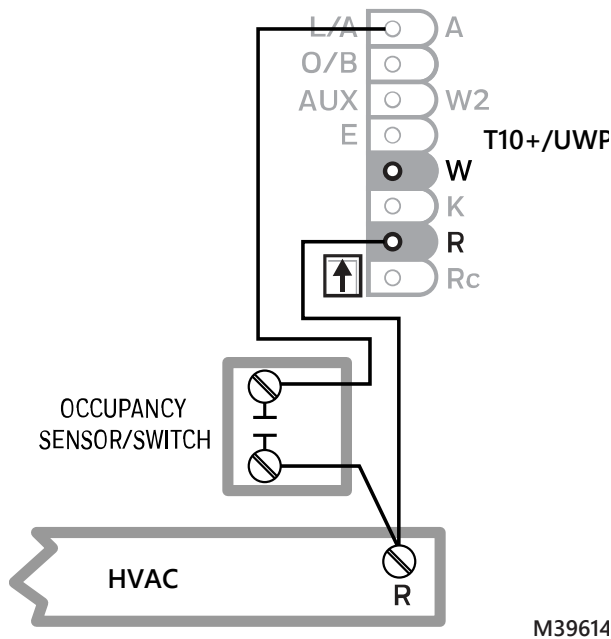

M39614

Figure 84: Remote Setback using a Dry contact switch on a T10+ Without EIM

Hotel Card Reader retrofit

If wires going to S and S on a previous thermostat went to a card reader or other dry-contact occupancy sensor, they can be wired to the T10+ thermostat or EIM as shown in the diagrams below.

A 10K/20K **cannot** be wired to L or R as shown below. A 10K/20K sensor wires to a set of S terminals at either EIM or T10+/UWP.

In retrofit installations: If T10+ is used without EIM, you can pig-tail one of the existing wires to R at the thermostat. Polarity does not matter when re-wiring to R and L at UWP. Then follow the following ISU settings.

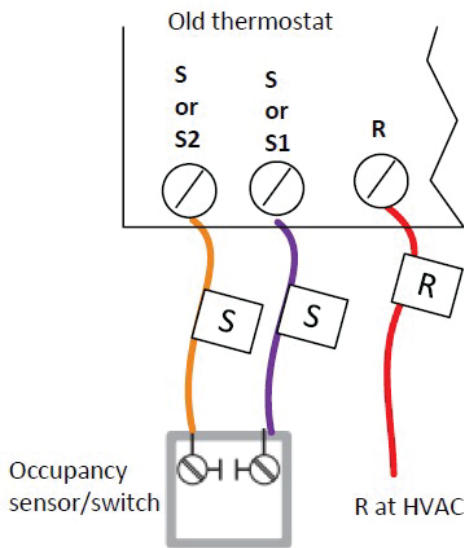

Figure 85: Hotel card retrofit 1

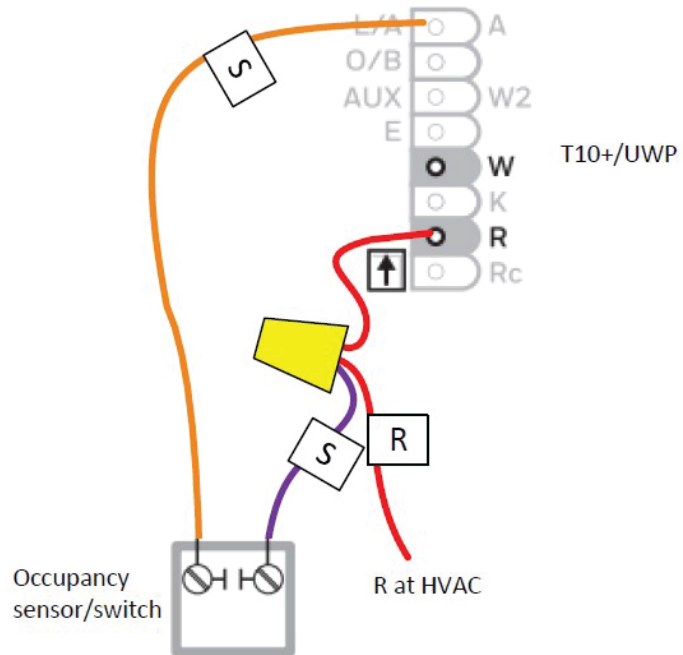
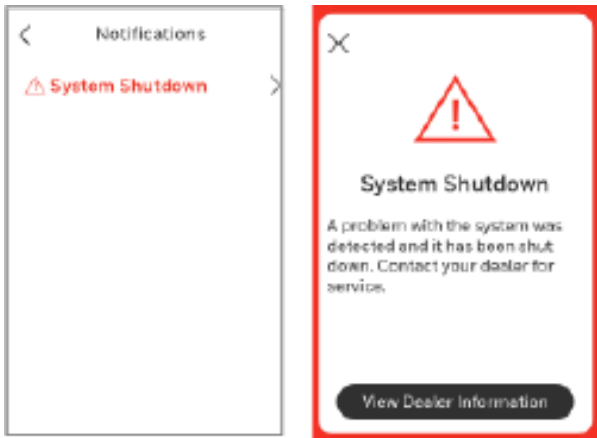

Figure 86: Hotel card retrofit 2

NOTE: These wiring diagrams do not show the rest of the system wiring, which will vary. See "Wiring at T10 or T10+ without EIM" on page 20 for system wiring not shown here.

Dry Contact Alerts (ISU 6000- 6220)

A Dry Contact device such as a wet switch can be connected to the S1, S2, S3, or S4 terminals at the Equipment Interface Module. When the dry contact device detects a problem, the thermostat displays an alert on the home screen along with the dealer information.



When the user presses the alert for more info, the Notification screen is displayed, prompting them to contact their dealer.

The following Dry Contact Alerts are available for the T10+ with EIM:

Full Drain Pan Alert

When the dry contact device detects that the condensate drain pan is full, the thermostat provides an alert to the user.

NOTE: When a Full Drain Pan Alert is selected, there is a follow up setting asking if you want to shut off the system when this alert is active or just send the alert message.

Dirty Filter Alert

When the dry contact device detects a dirty air filter (pressure drop across the filter), the thermostat provides an alert to the user to replace the filter.

Water Leak Alert

When the dry contact device detects a water leak, the thermostat provides an alert to the user.

NOTE: When a full Water Leak Alert is selected, and the T10+ is configured to control a humidifier there is a follow up setting asking if you want to shut off the humidifier when this alert is active or just send the alert message.

System Shutdown Alert

When the dry contact device detects a critical problem with the system, the thermostat alerts the user that the system was shut down. When the dry contact device detects a problem with the system (for example, smoke detection), the thermostat will not call for heating, cooling, fan or IAQ equipment until the dry contact is deactivated or the feature is no longer configured at the thermostat.

Service Needed Alert

When the dry contact device detects an issue that requires service, the thermostat provides an alert to the user.

Fan Failure Alert

The Fan Failure Alert protects the equipment when there is no airflow. When the dry contact device (for example, sail switch) detects no airflow for 5 minutes after a call for forced air heat, cool or fan, the thermostat alerts the user that the system was shut down due to a lack of airflow. The thermostat will call for the fan and lock out all other equipment until the dry contact device senses air flow again or the feature is no longer configured at the thermostat.

Custom Alert

Allows the dealer to enter a custom alert to be displayed when a dry contact device is activated. For example, a float switch can detect when your sump pump is not working.

Dry Contact Setup Example

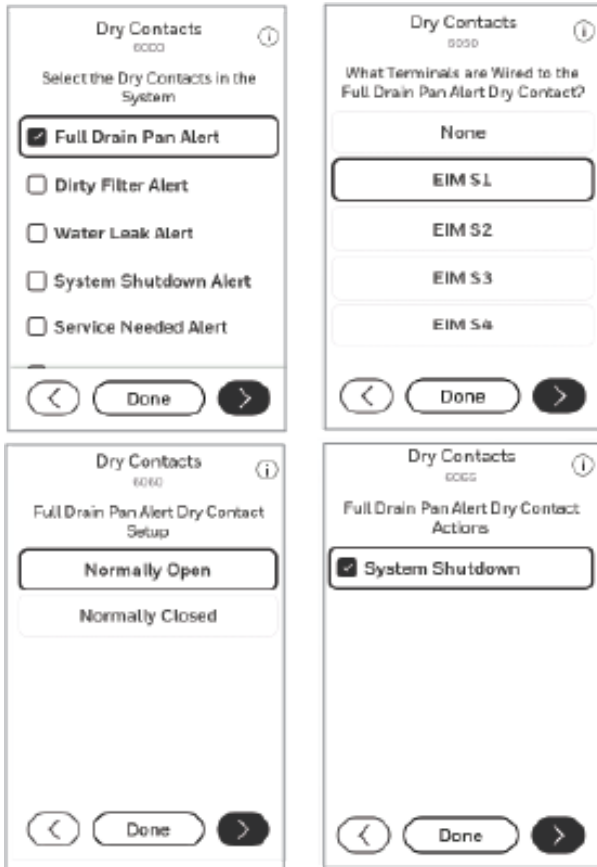

Dry Contact setup example

Custom Alerts 1 through 4

Allows the dealer to enter a custom alert to be displayed when a dry contact device is activated. For example, a float switch can detect when your sump pump is not working.

When Custom Alert 1 through Custom Alert 4 is selected in ISU 6005, the T10+ asks you to name the alert and then gives options for additional settings related to the alert. These settings are:

- **Which set of S terminals on the EIM the Dry Contact Alert is wired to (ISU 6190).**
 - There are four (4) sets of configurable S terminals on the EIM. If a set of S terminals is already configured for use by a different Dry Contact Alert (or sensor), it will not be configurable.
- **Whether the switch wired to these terminals is normally open or closed (ISU 6200).**
 - The switch wired to the S terminals could either be open in normal (not alert) conditions or closed.
- **Enter the Dry Contact Alert name (ISU 6210).**
- **Whether there is an alert message displayed when the alert is active (ISU 6215).**
 - In most cases, the installer would want an alert message to appear on the T10+ if there was a Dry Contact Alert active. However, the installer may be using the “alert” to do some other action (like running a ventilator when a sensor is reading high CO2). This may be normal operation and they may not wish to show an alert.

- **Lock Out Heat or Lock Out Cool (ISU 6230)**
 - If the installer chose to lock out heat or cool on a custom Dry Contact Alert condition, the T10+ will then ask if: "You want a delay before the lockout (ISU 6600 or 6620). For example, if someone was using a door sensor to lock out cooling, you wouldn't want to short cycle the cooling every time someone enters or exits. But if the door is left open for a certain length of time, you may wish to shut down the heat or cooling." Or, "If you still want a maximum temperature for cool (ISU 6610) or minimum indoor temperature for heat (ISU 6630). Example: If someone had a heat lockout configured when the window was open, they left the window open, and the indoor temperature dropped to 40°F, you probably still want the heat to run because the danger of pipes freezing overrides the inefficient use of heating with a window open"
- **Activate Fan (ISU 6230)**
 - If selected, this setting turns on the fan when the selected custom Dry Contact Alert (custom dry contact 1 through 4) is active.
- **Activate Custom U terminal (ISUs 6230, 6240, 6250, 6260)**
 - If you choose to activate a custom U terminal during a custom alert, the T10+ will ask you to name the U terminals used. That way the T10+ equipment status menu can show what is being turned on or locked out. For example, you could wire a shut off valve to the U contacts and the status would then show "Shut off valve energized" under equipment status.
- **Humidifier Lockout (ISU 8095)**
 - If the T10+ and EIM are set for a custom Dry Contact Alert and to control a humidifier, you can choose to lock out the humidifier during a custom Dry Contact Alert (the Water Leak Alert option also offers this setting).
- **Dehumidifier Lockout (ISU 9145)**
 - If the T10+ and EIM are set for a custom Dry Contact Alert and to control a dehumidifier, you can choose to lock out the dehumidifier during a custom Dry Contact Alert.
- **Turn On Ventilator (ISU 10065)**
 - If the T10+ and EIM are set for a custom Dry Contact Alert and to control a ventilator, you can choose to turn on the ventilator during a custom Dry Contact Alert.
- **Lockout Ventilator (ISU 10140)**
 - If the T10+ and EIM are set for a custom Dry Contact Alert and to control a ventilator, you can choose to lock out the ventilator during a custom Dry Contact Alert.

Battery Replacement

Indoor Sensor

Replace batteries in your indoor sensor when a warning appears on the thermostat screen, about 60 days before batteries are depleted.

When the sensor status light begins flashing red, battery power is critically low and will be depleted within 2–3 weeks. During normal operation, the status light remains off.

To replace the batteries:

- Remove the sensor from wallplate.
- Install 2 fresh AAA alkaline batteries. If the status light flashes green, batteries are good; if it flashes red, you must use fresh batteries.
- Attach sensor to wallplate.

The sensor will restore communication with the thermostat a few seconds after new batteries are installed.

Outdoor Sensor

Replace batteries in your outdoor sensor when a warning appears on the thermostat screen, about two months before batteries are depleted.

After new batteries are installed, the outdoor sensor will restore communication with the wireless network within a few seconds.

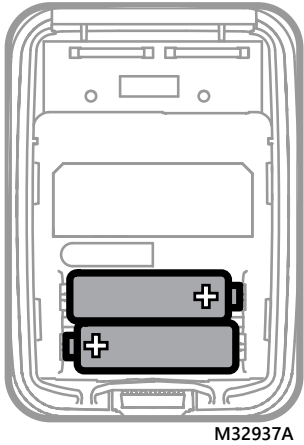
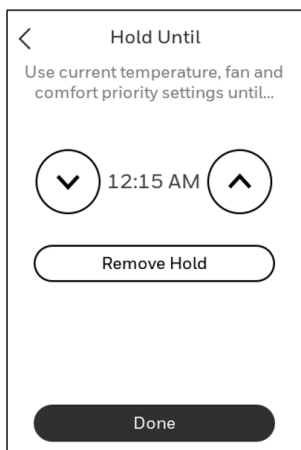

Figure 87: Outdoor sensor battery installation

Commercial Features

The thermostat can be set up for residential or light commercial applications (ISU 1010). When the thermostat is set up for Commercial, the thermostat meets Commercial Code, Title 24 and provides the following features:

- Commercial language (Occupied and Unoccupied)
- Temporary override (permanent hold is not allowed)
- Temporary override duration is limited to the amount set by the installer
- Adjustable ramp rates
- Initiate occupancy
- Displays name on home screen
- Remote setback using an occupancy sensor
- Economizer or Time of Day output
- Pre-occupancy purge
- Additional dehumidification control options



Select Residential or Commercial

Overriding Schedules: Commercial Use

Touch ▲ or ▼ to adjust the temperature. It will be maintained until the hold time you set.

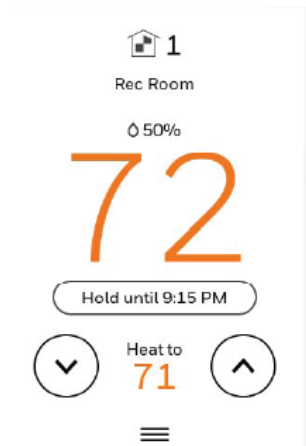

- To change the hold time, touch **Hold Until**. Then use the arrow buttons to change hold time. This time can be adjusted up to the maximum time set by the installer.
- Touch **Override** to use a pre-set occupied temperature if a person uses the room during an unoccupied period. The new temperature will be maintained for 1 hour and can be adjusted up to the maximum time set by the installer.

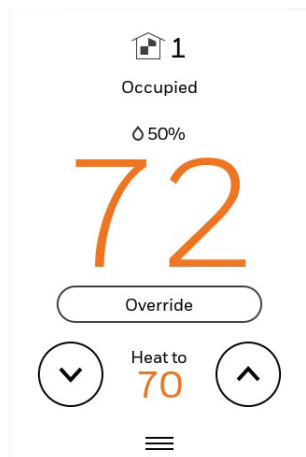

The programmed schedule will resume when the override timer expires. Touch **Cancel Hold** at any time to resume the program schedule.

Initiating Occupancy Mode: Commercial Use

This feature keeps temperature at an energy-saving level after the thermostat transitions from an **Unoccupied** schedule period to an **Occupied** schedule period until someone touches **Press to start occupancy**. When you arrive, touch the button to maintain a comfortable temperature while the room is occupied. This feature might be used in a school room that isn't occupied every day.



Touch the ▲ or ▼ buttons to set the temperature or the **Hold Until** time. The temperature is maintained until the time you set. Temperature returns to an energy saving level after the timer expires, or the **Occupied** period ends.

This feature is available only when programmed by the installer in ISU 4020 & 4030.

Ramp Rates

When the ramp rate is set to Off, the thermostat begins recovery at the scheduled time.

When a ramp rate is set, recovery begins early to reach the setpoint by the program time. Based on your recovery ramp setting and how far the thermostat is set back, the thermostat determines how early to turn on the system.

If the T10+ is set to use a wired sensor, wireless sensor, or **Internet for outdoor temperature** (ISU 1060), you can set outdoor temperatures for mild, cold and hot days in your region. By setting these outdoor temperatures, the thermostat will automatically adjust the ramp rate based on outdoor conditions. This allows the thermostat to save energy by starting recovery at the optimum time as outdoor conditions change.

NOTE: The thermostat uses an adjustable ramp rate when the thermostat is set up for Commercial. This allows the thermostat to recover on time during changing conditions (occupancy changes, temperature overrides, load conditions, opening/closing of doors, etc.) which are common in commercial applications.

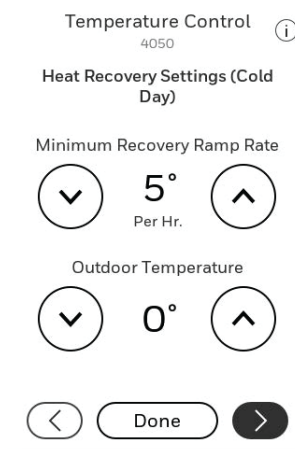
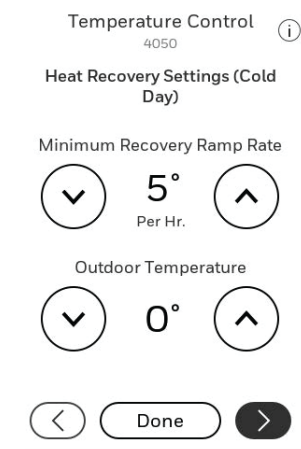

Custom Names

The thermostat location (name) can be displayed on the home screen. See the name "OFFICE". This is useful when multiple thermostats are mounted in a manager's office or equipment room, to quickly identify which thermostat controls a specific zone or area.

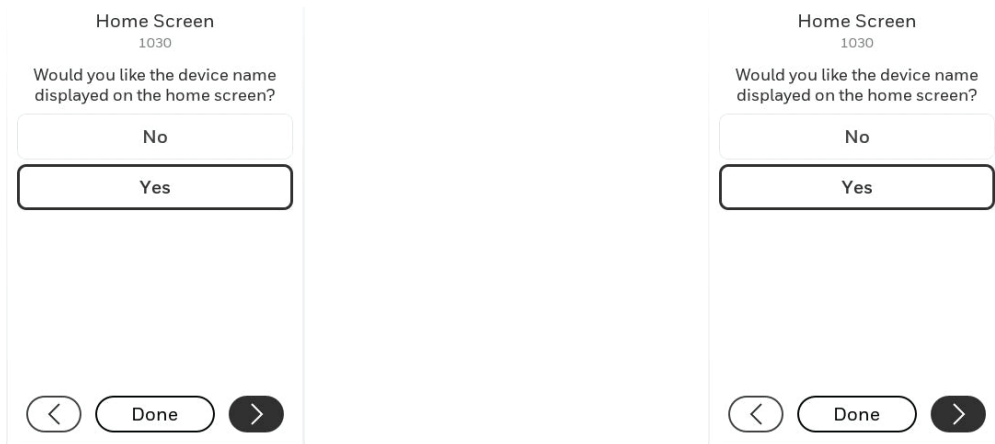

When configured for Commercial application, the T10+ will ask you to select the room where it is installed during initial setup. If you select **Yes** for ISU 1030, this is the name that will be displayed on the home screen. To change the name after setup is complete, go to **Installer Options > Devices and Sensors-Thermostat**. Then select **Change Room**. You may choose a pre-selected room name or choose **Other-Add-Room** to enter a custom name.

Economizer and Time of Day (TOD) Operation

Economizer

The T10+ thermostat controls an *Economizer* module to provide ventilation during occupied periods and free cooling when outdoor conditions are favorable. In some climates the cooling system may run several hours when it may not be required to maintain indoor comfort. When outdoor conditions are favorable, ventilation with outdoor air can achieve the same level of comfort at lower cost. ["Advanced Features" on page 100](#) explains how the Economizer Module is controlled by the thermostat.

The T10+ thermostat works with the Jade W7212 Economizer Module for conventional systems and the Jade W7213 and W7214 Economizer Modules for heat pump systems.

Economizer Operation

Thermostat Mode	Equipment Operation	U Contacts
Occupied	Heat/Cool running *	Closed
Occupied temporarily	Heat/Cool running *	
Occupied	Heat/Cool NOT running *	
Occupied temporarily	Heat/Cool NOT running *	
Pre-occupancy purge	Fan running	
Unoccupied	Cooling system running	
Unoccupied temporarily	Cooling system running	
Standby	Cooling system running	Open
Unoccupied	Cooling system NOT running	
Unoccupied temporarily	Cooling system NOT running	
Standby	Cooling system NOT running	Closed
Non-programmable	Fan running	
Non-programmable	Fan NOT running	Open

* Fan (G) always energized during Occupied & Occupied Temporary modes.

Time of Day (TOD)

The T10+ thermostat can be set up for a Time of Day output in the installer setup. This output is commonly used to control lighting panels, turning them on for occupied periods and off for unoccupied periods. The TOD Table explains how the TOD feature works with various thermostat modes.

TOD Operation

Thermostat Mode	U Contacts
Occupied	Closed
Occupied temporarily	
Temperature overrides	
Unoccupied	Open
Unoccupied temporarily	
Standby	
Non-programmable	

The Economizer Module and Time of Day output connect to the U terminal at the thermostat or EIM and are set up at ISU 2216-2220.

The image displays three sequential screenshots of the thermostat's installer setup interface:

- Screenshot 1 (ISU 2216):** Titled "Economizer/Time of Day", it shows three options: "None", "Economizer" (which is selected and highlighted with a black border), and "Time of Day".
- Screenshot 2 (ISU 2217):** Titled "Economizer", it asks "What terminals are wired to the Economizer output?". It lists three options: "None", "EIM U1" (selected and highlighted), "EIM U2", and "EIM U3".
- Screenshot 3 (ISU 2220):** Titled "L Terminal Alert", it shows two options: "None" and "Economizer Failure Indication" (selected and highlighted).

Each screenshot includes a "Done" button and navigation arrows at the bottom.

Pre-Occupancy Purge

The T10+ thermostat can be set up for Pre-Occupancy Purge in the installer setup (ISU 4010). When setup for Pre-Occupancy Purge, the thermostat runs the fan 1 to 3 hours before each occupied period to provide a comfortable workplace upon arrival. Options are Off and 1 to 3 hours.

The image shows the "Fan Control" (ISU 4010) setup screen. It is titled "Fan Control" and "Pre-Occupancy Purge Duration". The duration is set to "1 Hour", with a downward arrow on the left and an upward arrow on the right. At the bottom, there is a "Done" button and navigation arrows.

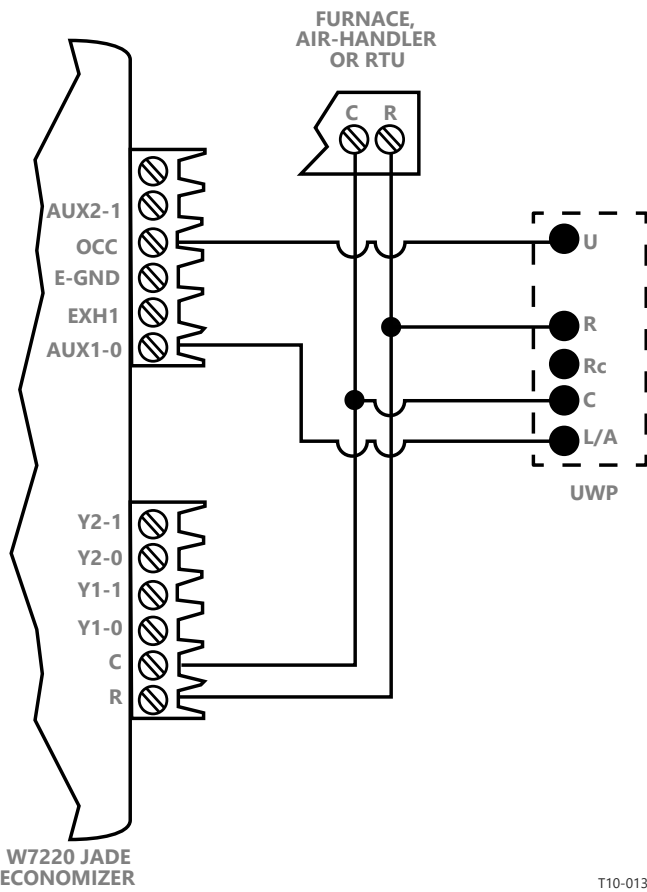
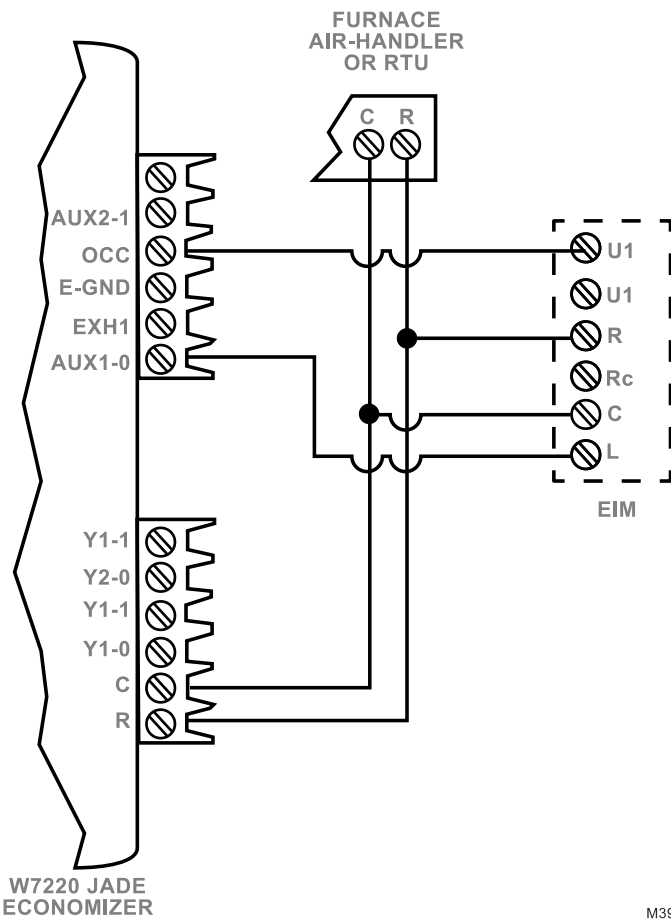

Figure 88: Economizer control using T10+ thermostat without EIM

NOTES:

- U Slider tab must be in **up** position on UWP.
- L/A only used if economizer fault indication is needed on T10+



W7220 JADE
ECONOMIZER

M39651

Figure 89: Economizer control using T10+ thermostat with EIM

NOTES:

- Any set of **U** contacts can be used (selected in ISU 2217). Jump the unused **U** from the selected set to **R** on the EIM as shown.
- **L** only used if Economizer fault indication is needed on T10+

RESIDEO PRO APP

The Resideo Pro app allows the installer to:

- Add multiple customer's information and link the thermostats to each customer.
- Get alerts through the pro app if a thermostat has an alert message.
- Get maintenance reminders messages through the app when the thermostat is displaying a reminder.

Steps

1. After doing the thermostat setup (linking to EIM if used, setting the system type and other ISU settings), select **MENU > THERMOSTAT INFORMATION** and scroll down to the QR code. Scan this code with your phone.
2. Open the Resideo Pro App. If you do not already have the Resideo Pro app, download the app and create your account.
3. Select **Customers**.

If the thermostat installed is for an existing customer choose them from the list. If it is a new customer, select "add customer".
Once you have finished adding the customer information below, the app will send an email to the customer inviting them to download the app if they don't already have the app or to connect the thermostat to WiFi if they already have the app and the thermostat wasn't added to WiFi by the installer.

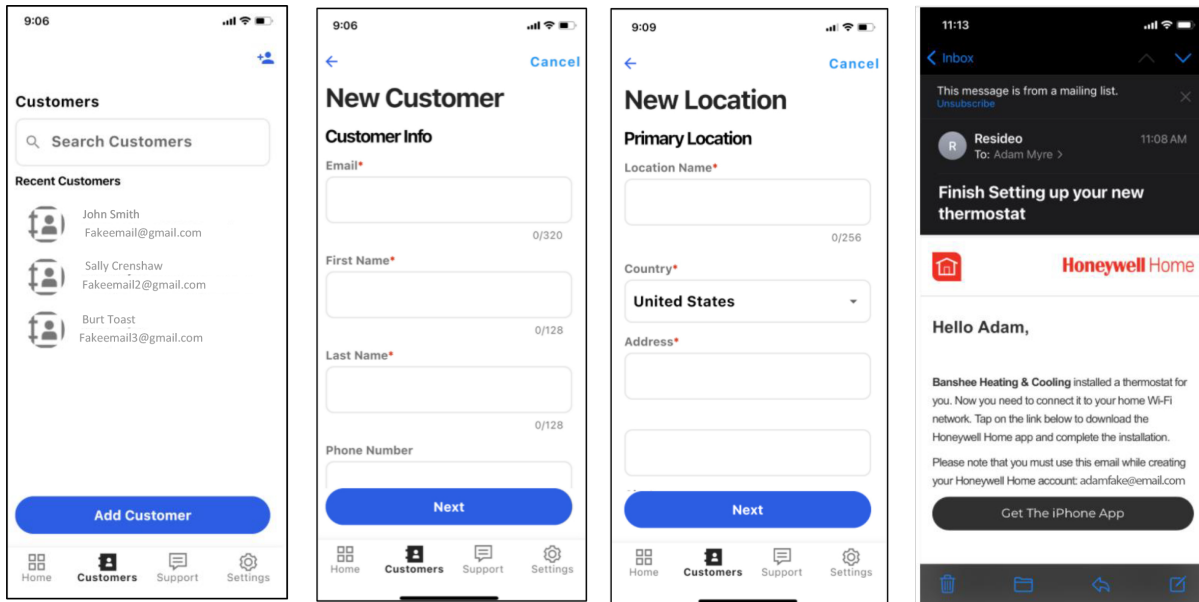

FAQ'S

WiFi connection questions

Q: Will the thermostat still work if the WiFi connection is lost?

A: Yes, you can still manually adjust the temperature at the thermostat. However, some features such as location-based temperature control (geofencing technology) can only be managed through the First Alert or Resideo app and will not function without a WiFi connection. The thermostat will automatically reconnect to WiFi once the network is restored.

Q: Is there a way to extend the strength of my WiFi signal?

A: The range (distance) of your WiFi signal is determined by your router. Try moving your router closer to the location of the thermostat, or use a router with a stronger signal range.

Q: There's an alert that says "WiFi signal lost" - what should I do?

A: Wait 5 minutes for the thermostat to reconnect or select an alternate network (if you have one) in the First Alert or Resideo app configuration menu. If the thermostat isn't able to reconnect, you'll need to troubleshoot the router to determine the cause.

First Alert or Resideo account and app questions

Q: Why haven't I received an account activation email?

A: If you haven't received an activation email after 5 minutes, check your Spam folder and look for an email from customer-service@resideo.com. If you don't see it, tap **Resend** to have the activation email resent. If you still don't receive it, please contact the Technical Support team at 1-800-633-3991.

Q: Can I set up my thermostat with multiple users?

A: Yes. To add users, log into the First Alert or Resideo app and tap the menu icon in the upper left corner. Select Manage Users, tap Add User and type in the email addresses of the people you'd like to invite. If they already have a First Alert or Resideo account set up, the thermostat and its location will automatically be added to their account. If they don't have an account, they'll receive an email prompting them to download the app and create a new account.

Q: Can I set up location-based temperature control with multiple users?

A: Yes. Location-based temperature control (Auto Away/geofence technology) will activate based on the last person who leaves and the first person to return. Each user will need to create their own First Alert or Resideo app account with a login ID and password. Two users should not share the same account. Each user will then need to enable location-based temperature control.

Q: Why doesn't a change I made in the app show up on the thermostat?

A: There may be a short delay when you make temperature and settings changes in the First Alert or Resideo app. Wait a few minutes, and if you still don't see your changes on the thermostat, make sure the thermostat is still connected to WiFi and restart your app.

Software and security questions

Q: How can I be sure my thermostat is running the most up-to-date firmware?

A: When your thermostat is connected to WiFi, it will automatically receive over-the-air firmware updates from the app. These firmware updates contain things such as new features as well as security upgrades. Keep your thermostat connected to WiFi to ensure it receives these updates.

Q: How can I prevent a cybercriminal from making unauthorized changes to my thermostat?

A: If a cybercriminal gains access to your WiFi router, they can tamper with a wide range of online activities, including the settings on your connected devices. Make sure you change the default password on your WiFi router, and when you select a new password, make sure it uses multiple upper- and lower-case letters and special characters.

Other questions

Q: How can I uninstall my T10/T10+ Smart thermostat?

A: If you want to replace your T10/T10+ Smart thermostat, or if you're moving out of your home and leaving the thermostat behind, you'll first want to clear out the personal settings that are stored on the thermostat. (Even when disconnected from power, the thermostat will keep your settings and home router information in memory.) We recommend resetting the thermostat's WiFi and HomeKit® settings (if previously connected).

Q: Is there a motion sensor in the thermostat?

A: There is not a motion sensor in the thermostat. In most homes, the thermostat is mounted in a hallway, so when using active rooms for priority sensing, we would want to exclude the thermostat.

Q: What happens if "Active rooms" is used and no motion is detected in any of the rooms with sensors?

A: If the thermostat is set to control by active rooms, and no motion is detected, the sensor in the thermostat is used and the remote sensors are excluded. Most people schedule the sleep period to use "Selected sensors" rather than "active sensors" and choose the bedrooms for the sleep schedule.

The T10+ has a setting for "Fallback sensor" which would be used rather than the thermostat if selected.

Q: When using active rooms, how long are those rooms considered "Active" after motion has last been detected?

A: The sensor has an occupancy algorithm based on how many motion events it sees within a certain timeframe. This was set up so that if someone briefly walks through a room, the sensor will tell the thermostat that the room is "occupied" for 10 minutes. If someone is in a room longer, then the timeout will be increased automatically.

Sensors communicate directly with the thermostat via Honeywell Home RedLINK technology. After sensing motion, the communication should take less than 3 seconds to assign the room priority, depending on battery and signal strength.

Q: How do the wireless indoor sensors detect motion.

A: The sensors use a Passive Infrared Sensor (PIR) detector.

Q: How does motion-based priority work with multiple people in the house?

A: If the thermostat's priority is set to 'Active Rooms', then any room that detects motion will become prioritized. The average of those rooms' temperatures will be monitored so that the thermostat can adjust to your preferred temperature set-point. If one of the sensors no longer detects people in that room, that sensor will adjust after a period of time, using the algorithm based on motion events that it sees within a certain time frame.

Q: What's the range of detection on the motion sensor?

A: There are many factors that can affect this (height, body size, layers of clothing, temperature of clothing, angle, etc.). The typical range of our sensor is up to 20 feet.

TROUBLESHOOTING AND SUPPORT

If you have difficulty with your thermostat, please try the following suggestions. Most problems can be corrected quickly and easily.

Display is blank:

- Check circuit breaker and reset if necessary.
- Make sure power switch for heating & cooling system is on.
- Make sure furnace door is closed securely.
- Make sure the C wire is connected.

Heating or cooling system does not respond:

- Press **Menu > System Mode > Heat > Done** to set the system to Heat mode. Make sure the desired temperature is higher than the indoor temperature.
- Press **Menu > System Mode > Cool > Done** to set the system to Cool mode. Make sure the desired temperature is lower than the indoor temperature.
- Check circuit breaker and reset if necessary.
- Make sure power switch for heating & cooling system is on.
- Make sure furnace door is closed securely.
- Wait 5 minutes for the system to respond.

Temperature settings do not change:

Verify the thermostat is set to the correct mode. Press **Menu-Mode** to change mode setting.

If the display indicates “screen locked” when you press the up or down arrow, you can unlock the screen by selecting menu-security settings.

The thermostat may be preventing you from changing the set-point above or below a certain setting because of installer configured minimum and maximum settings. See the ISU settings for 4100.

Default minimum and maximum settings:

- Heat: 40 °F to 90 °F (4.5 °C to 32.0 °C)
- Cool: 50 °F to 99 °F (10.0 °C to 37.0 °C)

Heat runs with thermostat in cool or off mode:

Does the display show “Freeze Protection active”? If so, the installer set the thermostat for a freeze protection temperature that maintains a minimum temperature even when the thermostat is set to off or cool. This feature will generate an alert message if the temperature drops below the freeze protection setting.

Aux heat runs in cooling:

- For heat pump systems, verify there is not a wire attached to W on the UWP.

Cool runs with a call for heat:

- Verify that the O/B wire is making a good connection and verify the changeover valve setting is correct for the heat pump used (ISU 2060).

Heat doesn't come on:

Verify the thermostat is set to Heat, Em Heat, or Auto mode and verify that the heat setpoint is above room temperature. Does the display indicate “**Heating to**” with an orange display screen? If so, the thermostat is attempting to run the heat.

- If “**Heating to**” is displayed in orange, and heat does not come on after a short delay, verify the wire connections, R/Rc slider jumper on UWP (or R, Rh, and Rc jumpers if an EIM is used). If those variables check out, your HVAC contractor can call Tech Support to verify configuration and for further troubleshooting.
- If display isn't showing “HEATING TO” (rather than “HEAT TO”) or “WAITING FOR EQUIPMENT” but heat setpoint is above room temperature, go to EQUIPMENT STATUS.
- See if there are any active alerts. The T10+ with EIM can be set to lock out the heat during an active alert. A custom Dry Contact Alert set to lock out heat could have been snoozed (or set to not display alert message by installer) but equipment status would show the heat as “Idle (Dry contact lockout)”. If display shows “waiting for

equipment” then the thermostat is holding off running the heating to prevent short cycling. This delay should last 5 minutes at most. If you time this and it is longer than 5 minutes, it is possible you are intermittently losing power to the thermostat. As a test you could remove all wires besides R and C from UWP (or EIM if T10+ is linked to an EIM and then test the heat. If the thermostat then indicates a call for heat within 5 minutes, a shorted wire or high equipment draw could be interrupting power to the thermostat momentarily at the start of a heat call.

Cool doesn't come on:

Verify the thermostat is set to Cool or Auto mode and verify that the cool setpoint is below room temperature. Does the display indicate “Cooling to” with a blue display screen? If so the thermostat is attempting to run the cooling.

- If **“COOLING TO”** (rather than “COOL TO”) is in a blue display, and cooling does not come on after a short delay, verify the wire connections, R/Rc slider jumper on UWP (or R, Rh, and Rc jumpers if an EIM is used with T10+). If that all checks out contact HVAC contractor. Contractor can call tech support to verify configuration and further troubleshooting.
- If display isn't showing **“COOLING TO”** or **“WAITING FOR EQUIPMENT”** but **COOL setpoint is below the room temperature**, go to EQUIPMENT STATUS.

Check for any active alerts. The T10+ with EIM can be set to lock out cooling during active alerts. A custom Dry Contact Alert set to lock out cooling could have been snoozed (or set to not display alert message by installer) but equipment status would show the cooling as “Idle (Dry contact lockout)”. If display shows **“waiting for equipment”** then the thermostat is holding off running the cooling or to prevent short cycling. This delay should last 5 minutes at most. If you time this and it is longer than 5 minutes, you may be intermittently losing power to the thermostat. To test, remove all wires besides R and C from UWP (or EIM if T10+ is linked to an EIM) and then test the cooling. If the thermostat then indicates a call for cool within 5 minutes, a shorted wire or high equipment draw could be interrupting power to the thermostat momentarily at the start of a cool call.

Weather menu isn't displayed:

This menu is only shown when the thermostat is connected to WiFi and the app. If WiFi connection is lost, the thermostat will not show that option until connection is restored.

Cooling runs below setpoint:

Verify the cooling is running while cool setpoint is above the room temperature reading on the display. If so, verify the thermostat is deliberately running cooling. When doing so, the display is blue and it shows **“Cooling to”** (rather than “COOL TO”). Also, menu equipment status will show if the thermostat is trying to run cooling or not.

- If the display shows **“Cooling to”** and a setting that is above the room temperature reading it is likely the T10 or T10+ has been set to over-cool when humidity is high. Go to the Dehumidity setting in **MENU**. If that display shows a status of “DEHUMIDIFYING” select **OPTIONS** and deselect **USE DEHUMIDIFICATION**. Then go back to the home screen and see if the cool call ends. The T10 or T10+ can run the cooling up to 3 degrees below the cool setpoint if configured to use the air conditioner for dehumidification.

Fan is running unexpectedly:

- The T10 & T10+ has different settings that might have turned on the fan. Check EQUIPMENT STATUS to see what the T10 or T10+ indicates it is running.
- The T10 & T10+ could be set to run the fan with a call for ventilation, humidification, or dehumidification.
- The T10 or T10+ will also run the fan with a call for cooling and in forced air systems the fan will also run with a call for heat (but this may or may not be controlled by the thermostat depending on the system type settings).
- There are ISU settings for extended fan run in heat or cool mode (ISU 3260) which can be set for up to 15 minutes.
- Additionally, the T10+ has a “TEMPERATURE AVERAGING” option to run the fan to average hot spots and cool spots if a remote sensor is used. This would have been configured by the installer in the ISU. To see if this is being used, go to menu and look for TEMPERATURE AVERAGING. If that option appears, select it and see if it is currently active.
- The T10 & T10+ can have the fan set to on, auto, or circ for each schedule period.
- If the thermostat doesn't indicate the fan is on under the EQUIPMENT STATUS menu, it is possible something else in the system is controlling the fan such as a separate control for a humidifier, dehumidifier or ventilator.

Fan will not run when expected:

If the thermostat is set to control a heat-only system such as a boiler, there will not be a fan setting. Check equipment status. This will show the fan state. If it says "**Idle (Fan Lockout)**", then the installer configured the T10+ to lock out fan at the end of a call for cooling for anywhere from 5 to 90 minutes (ISU 3125). This is set up for some homes in very humid regions where running the fan at the end of a cool call can blow air over a wet coil and re-introduce humid air back into the space.

Display doesn't show indoor humidity:

The T10+ has an ISU setting to not display indoor humidity (ISU 14050).

Display changes color or goes blank at night:

There are multiple settings under **Temperature > Display > Inactive Night Backlight** (on T10+) or **Inactive Sleep Backlight** (on T10). These settings allow you to set a time for the display to go dim or go dark. (Dark option on T10+ only).

I cannot link my T10+ to the EIM:

Verify that you have a T10+ rather than a T10 and that you have the correct EIM for this model. T10+ models are THX321WF3003W and THX321WFS3001W

- EIM is THM04R3000
- The T10+ and EIM are included in YTHM1004R3000 and YTHM1004R3001 kits.
- If the T10+ had already been configured without an EIM, you need to do a factory reset of the thermostat to get to the initial screen that allows you to choose to use it with an EIM. Then follow the instructions on T10+ display.

I cannot link my T10+ to the wireless outdoor sensor:

Verify that you have a T10+ rather than a T10 and that you have the correct wireless outdoor sensor for this model. T10+ models are THX321WF3003W and THX321WFS3001W

- Outdoor sensor is C7089R3013 (not C7089R1013)
- The T10+ and outdoor sensor are included with an EIM in the YTHM1004R3001 kit.
- See the instructions for adding an outdoor sensor in this document.

Wi-Fi and app-related issues:

See "[WiFi Setup](#)" on page 74.

Active Rooms is selected but one or more of my sensors doesn't register activity:

Go to MENU/PRIORITY ON THERMOSTAT. Verify active rooms is selected. View the status of the sensor(s) in question in that screen. If there is not an indication of occupancy by that sensor (green person next to sensor name) move in front of the sensor. If that doesn't change the status of the sensor:

- Verify the sensor you are testing is the one you see in the display. To do so, go to **Devices and Sensors** and select the sensor name.
- Verify the **Use Motion** slider is set to Enabled.

If so, select **OPTIONS/BLINK LIGHTS**. Go back to the sensor and verify it has a blinking light.

If not, check the other sensors in the home to see if the sensors were placed in the wrong rooms.

C7189R2002 or C7189R3002 wireless indoor sensor will not connect to my T10 or T10+:

Following the discontinuation of C7189R2002 sensors and the introduction of C7189R3002 sensors, there was a period during which the new sensors worked with existing T10+ thermostats and the new T10+ thermostats worked with the existing sensors.

Beginning with units manufactured in Autumn 2024 (date codes 2440 and later) **T10+ thermostats will only work with C7189R3002 sensors** and **C7189R3002 sensors will only work with T10+ thermostats**. Older thermostats and sensors that cannot connect should be replaced.

Thermostat is losing time:

If the T10/T10+ is used with HomeKit without registering the thermostat to the First Alert or Resideo app, it may lose time. We recommend registering the thermostat to the First Alert or Resideo app, even when controlling it through HomeKit.

Customer Assistance

For assistance with this product, please visit customer.resideo.com.

Or, call Resideo Customer Care toll-free at [1-800-633-3991](tel:1-800-633-3991).

5-year limited warranty

For Warranty information go to honeywellhome.com/support

REGULATORY

Regulatory information

FCC REGULATIONS

47 CFR § 15.19 (a)(3)

This device complies with part 15 of the FCC Rules. Operation is subject to the following two conditions:

- 1: This device may not cause harmful interference, and
- 2: This device must accept any interference received, including interference that may cause undesired operation.

47 CFR § 15.21 (USA only)

Changes or modifications not expressly approved by the party responsible for compliance could void the user's authority to operate the equipment.

47 CFR § 15.105 (b)

See <https://customer.resideo.com/en-US/support/residential/codes-and-standards/FCC15105/Pages/default.aspx> for additional FCC information for this product.

IC REGULATIONS RSS-GEN

This device complies with Industry Canada's license-exempt RSSs. Operation is subject to the following two conditions:

- 1: This device may not cause interference; and
- 2: This device must accept any interference, including interference that may cause undesired operation of the device.

UL and ULC Listed per Standards UL 60730-1 and CAN/CSA E60730-1



CAUTION: ELECTRICAL HAZARD

Can cause electrical shock or equipment damage. Disconnect power before beginning installation.



CAUTION: EQUIPMENT DAMAGE HAZARD

Compressor protection is bypassed during testing. To prevent equipment damage, avoid cycling the compressor quickly.



CAUTION: MERCURY NOTICE

If this product is replacing a control that contains mercury in a sealed tube, do not place the old control in the trash. Contact your local waste management authority for instructions regarding recycling and proper disposal.



CAUTION: ELECTRONIC WASTE NOTICE

The product should not be disposed of with other household waste. Check for the nearest authorized collection centers or authorized recyclers. The correct disposal of end-of-life equipment will help prevent negative consequences for the environment and human health.

resideo

www.resideo.com

© 2025 Resideo Technologies, Inc.

The Honeywell Home trademark is used under license from Honeywell International, Inc.
This product is manufactured by Resideo Technologies, Inc. and its affiliates.

Apple, iPhone, iPad, iPod touch and iTunes are trademarks of Apple Inc. All other trademarks are the property of their respective owners.

Resideo Technologies Inc.
Scottsdale, AZ 85254.

33-00462-07 L.Y. 02-25