

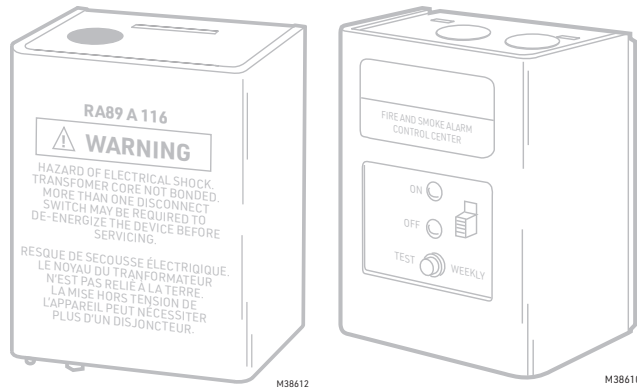

R182J, R482J, R845A, R847A, R882J, RA89A, RA832A Switching Relays

PRODUCT DATA



FEATURES

- Relays with 24V control coils: R182J, R882J, R847A, RA89A, RA832A, and R845A.
- Relays with line voltage control coils: R482J.
- Relays with internal 24V transformer: R182J, RA89A, RA832A, R845A, and R847A.
- Relays for use with an external 24V supply: R882J.
- Heavy duty relays: R847J.
- R847A has flexible internal leads to provide either spst or spdt switching.
- RA832A has contacts for low voltage and millivoltage (Powerpile®) use.

APPLICATION

These relays provide intermediate or heavy duty service in a wide variety of switching configurations.

SPECIFICATIONS

IMPORTANT:

The specifications given in this publication do not include normal manufacturing tolerances. Therefore, this unit may not exactly match the listed specifications. Also, this product is tested and calibrated under closely controlled conditions, and some minor differences in performance can be expected if those conditions are changed.

Models: See Table 1

Table 1. Switching Relay Specifications.

Models	Application	Voltage (50/60 Hz)	Switch Action	Control Circuit	Coil Voltage (Vac at 50/60 Hz)	Relay Coil Current (A)	Contact Ratings (A)	
							AFL	ALR
R182J	For 24V thermostat control of line voltage devices.	120	Dpdt	3-wire	24	0.40 ^a	7.4	44.4
		240					3.7	22.2
R482J	Controlled by a line voltage controller	120		2-wire	120	0.08	7.4	44.4
		208/240			208/240	0.04	3.7	22.2
R845A	For hot water zone control systems or spst control of two separate loads.	120	Dpst		24	0.40	7.4	44.4
R847A	Provides switching for high-current loads such as cooling compressors.	120					22	100
		240					10	50
R882J	For use with separate low voltage power source.	24	Dpdt				7.4	44.4
RA89A	For switching one line voltage load.	120	Spst				10.2	61.2
RA832A	For switching two line voltage loads having a common power source.	120	Dpst				7.4	44.4
		240					3.7	22.2

^a See footnote on page 3.

^a IMPORTANT:

The transformer on the R182 can overheat when used with a series 20 thermostat if the total resistance of the thermostat (including thermostat wire and thermostat contact resistance) exceeds 2.5 ohms, add a 100 ohm, 10 watt resistor between the W and R terminals. Table 2 gives maximum thermostat wire runs; if longer runs are necessary, measure the resistance or add a 100 ohm, 10 watt resistor across terminals W and R.

See Table 2 for the ratings of built-in transformer (all transformers are rated at 120/240V, 50/60 Hz).

Table 2. Transformer Ratings.

Transformer	Rating (watts)
R847A	7.0
RA89A	5.0
RA832A	—
R845A	—
R182J	6.5

FINISH: Gray enamel.

KNOCKOUTS:

Case bottom: (2) RA89A, RA832A, R845A; (3) R182J, R482J, R882J.

All models have 1 wiring hole in case top.

All knockouts are for 1/2 in. [12.7 mm] conduit.

APPROVALS:

Underwriters Laboratories Inc. Listed: RA89A; RA832A, R882J; R845A: File no. E4436, Guide no. XAPX. R482J: File no. E14480, Guide no. NLDS. R847A: File no. SA481, Guide no. SDFY.

Canadian Standards Association Certified: R482J; R882J; R847A: File no. LR1620.

Mounting

For replacement, mount the relay in the same location as the old control. If this is a new installation, locate the relay vertically on a solid wall or partition as near as possible to the device to be controlled. Select a location that is easily accessible for installation and service.

NOTE: To reduce possible transformer hum and relay noise that can be amplified by mounting surfaces of sheetmetal, plasterboard, and similar materials, place rubber or felt washers between the case and the mounting surface.

1. Position the relay and mark the mounting holes. See Fig. 1.
2. Start a screw for the keyhole type mounting hole in the upper right-hand corner. Turn down screw within about 1/8 in. [3.2 mm] of the surface.
3. Hang the relay on the screw, position the case, and start the bottom screw.
4. Tighten both screws.

IMPORTANT:

The switching relay terminals are approved for use with copper wires only.

All wiring must comply with all applicable electrical codes, ordinances, and regulations. Follow any instructions furnished with the controlled equipment.

See Fig. 2 through 10 for hookup diagrams for these relays. When two or more devices are to be controlled in parallel, the total current must not exceed the relay load rating. Fig. 11 is an internal view of the RA832A, showing terminal locations and barriers.

Never connect load terminals to a load that takes more current than the amount listed in the electrical ratings on the relay. See Table 3 for wiring length specifications.

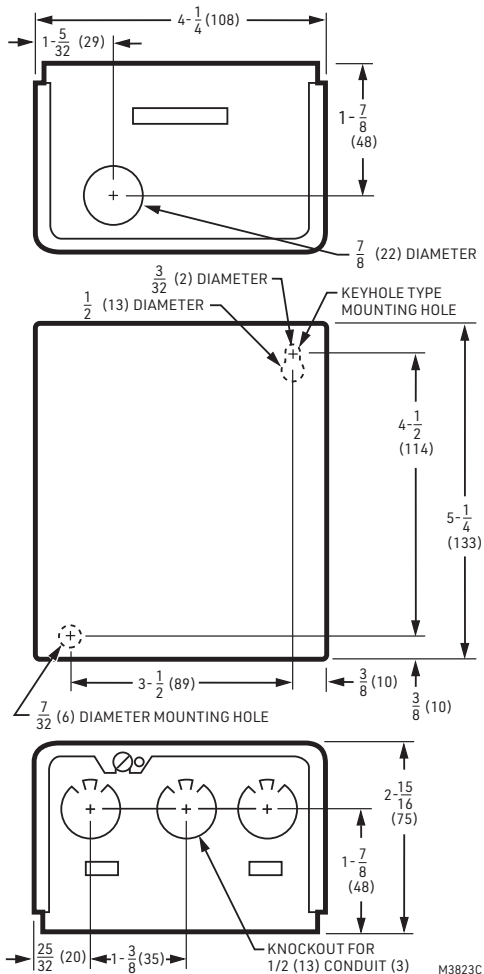

Fig. 1. Approximate mounting dimensions in in. [mm].

INSTALLATION

When Installing this Product...

1. Read these instructions carefully. Failure to follow them could damage the product or cause a hazardous condition.
2. Check the ratings given in the instructions and on the product to make sure the product is suitable for your application.
3. Installer must be a trained, experienced service technician.
4. After completing installation, use these instructions to check out product operation.

⚠ WARNING

Electrocution hazard. Can cause property damage, severe injury, or death.

Transformer core not bonded.
Disconnect power supply before wiring to prevent electrical shock or equipment damage.

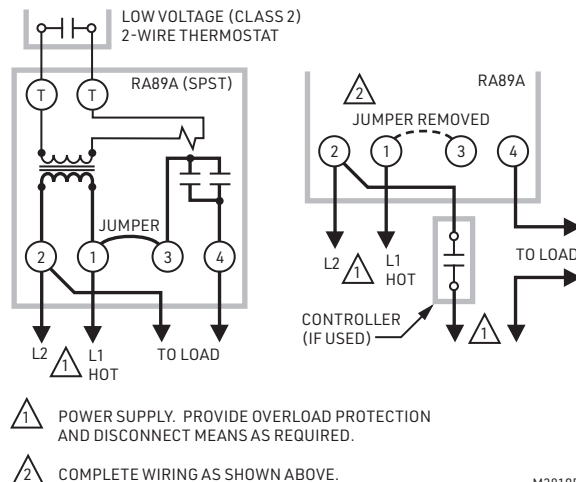

Fig. 2. Internal schematic and typical hookup for RA89A.

Table 3. Wire Length Specifications

AWG Wire Size (Number)	Total Wire Length		Length of Run to Thermostat (2 wires)	
	Feet	Meters	Feet	Meters
22	120	38	60	18
20	200	61	100	30.5
18	300	91.5	150	45.6
16	500	152.5	250	76
14	800	244	400	122

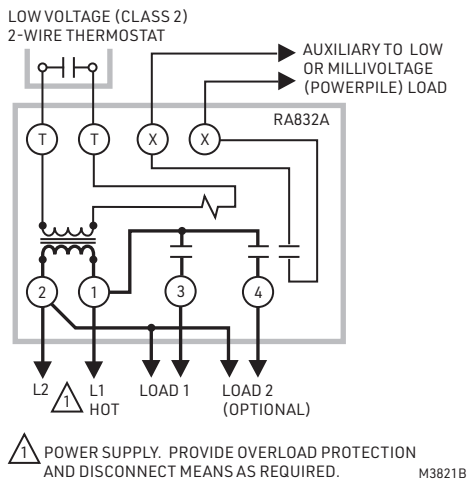

Fig. 3. Internal schematic and typical hookup for RA832A.

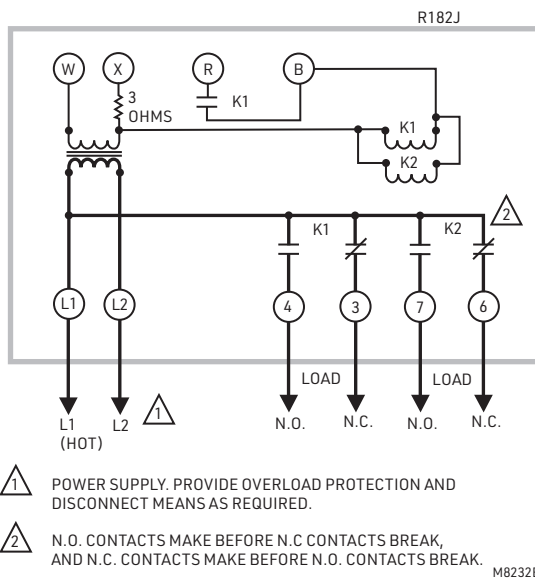

Fig. 4. Internal schematic and typical hookup for R182J.

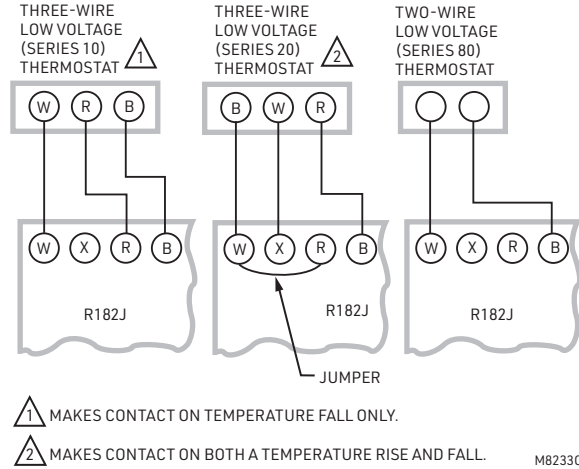

Fig. 5. Thermostat connections for R182J.

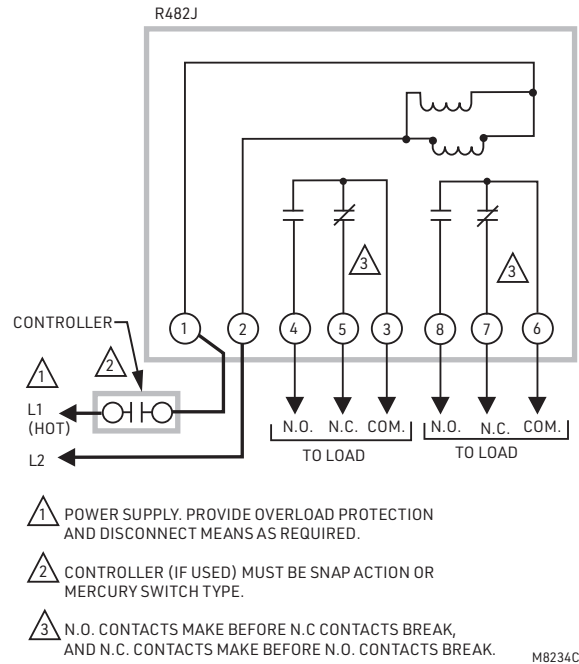

Fig. 6. Internal schematic and typical hookup for R482J.

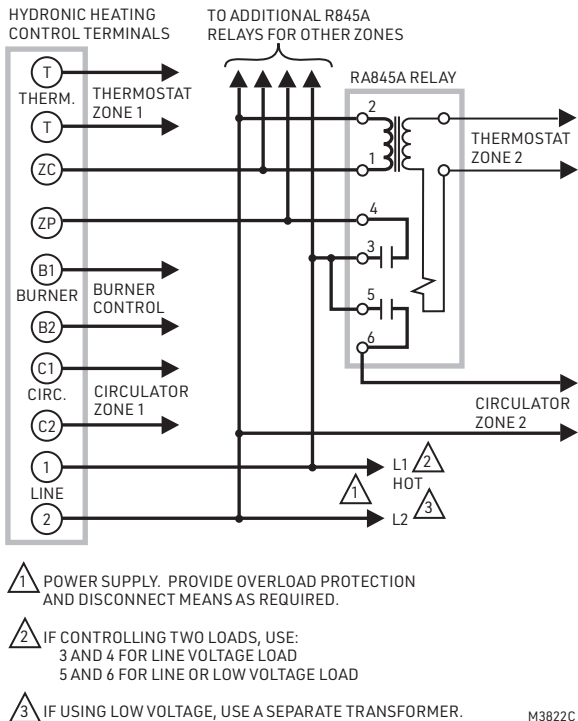

Fig. 7. Schematic diagram showing R845A in multizone, forced hydronic heating system. This arrangement is suitable for any number of additional zones.

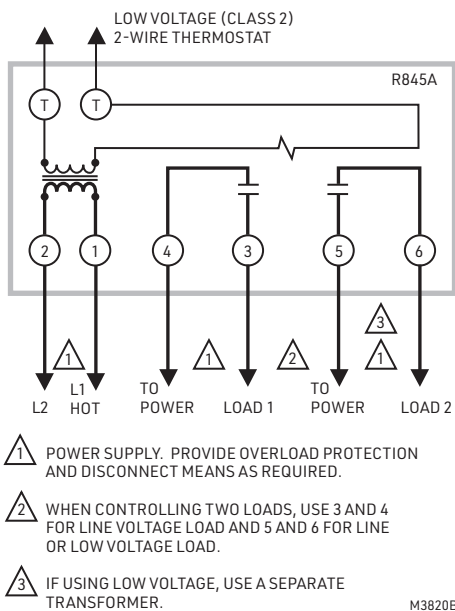

Fig. 8. R845A hookup for controlling two loads.

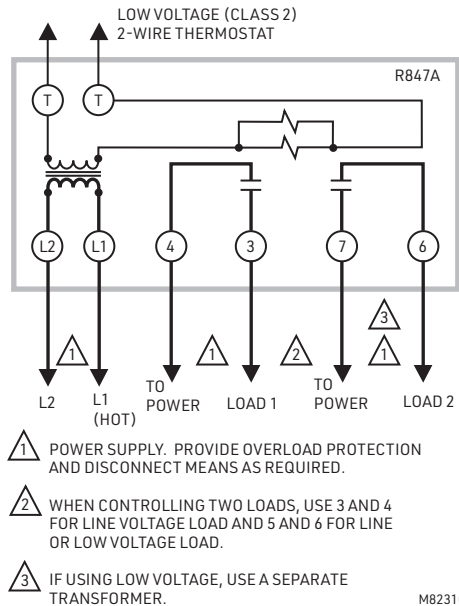

Fig. 9. Internal schematic and hookup for R847A.

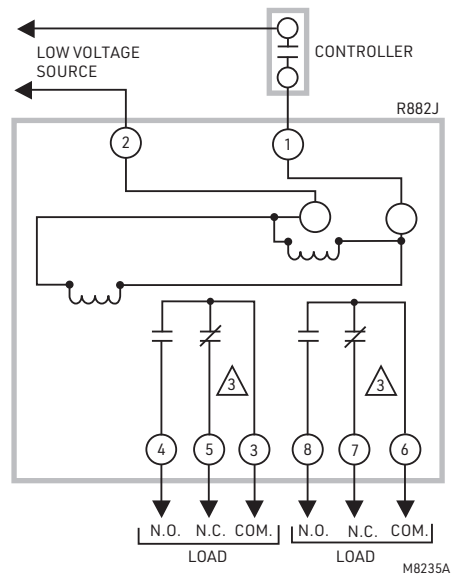

Fig. 10. Internal schematic and hookup for R882J.

SERVICE AND CHECKOUT

1. Never use oil on any part of the relay coil or contacts.
2. Keep the cover on the relay during normal operation and remove only for service and checkout.
3. Relay contacts require no cleaning; contacts close with a wiping action and are self-cleaning. They may turn black after being in service for some time; however, this discoloration does not prevent proper operation.
4. After installation is complete, operate system through at least one cycle from the controller to make certain the relay controls the equipment as intended.

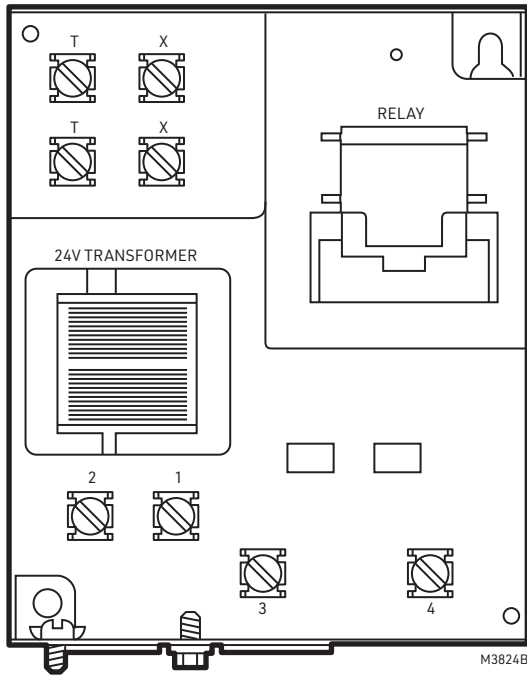

Fig. 11. Internal view of RA832A Switching Relay.

R182J, R482J, R845A, R847A, R882J, RA89A, RA832A SWITCHING RELAYS



Resideo Technologies, Inc.
1985 Douglas Drive North, Golden Valley, MN 55422
1-800-468-1502
60-2481-03 M.S. Rev. 04-21 | Printed in United States

www.resideo.com

© 2021 Resideo Technologies, Inc. All rights reserved.
This product is manufactured by Resideo Technologies, Inc. and its affiliates.