



VR8300 Continuous Pilot Combination Gas Control

INSTALLATION INSTRUCTIONS

APPLICATION

These continuous pilot gas controls are used in gas-fired appliances with capacities up to 200 cfh at 1 in. wc pressure drop (5.7 cmh at 0.25 kPa) on natural gas. Included are a manual valve, safety shutoff, two automatic operators, and a pressure regulator. See Table 1 for temperature range and regulator type.

The VR8300 setup for natural gas includes a 393691 LP Conversion Kit. The kit contains a new cap screw, a pressure regulator adjustment screw, a tapered spring and a conversion label. The LP to Natural gas conversion kit is 394588. Step-opening gas controls cannot be converted.

Conversion Kits:

Natural to LP conversion kit is 393691. LP to Natural conversion kit is 394588. Conversion kits contain a new cap screw, a pressure regulator adjustment screw, a tapered spring and a conversion label. Step-opening gas controls cannot be converted.

Size (Inlet x Outlet)	Capacity at 1 in. wc Pressure Drop ^a	Minimum Regulated Capacity		Maximum Regulated Capacity
		Capacity		
1/2 in. x 1/2 in.	180 cfh (5.1 cmh)	30 cfh (0.8 cmh)		225 cfh (6.4 cmh)
1/2 in. x 3/4 in.	190 cfh (5.4 cmh)	30 cfh (0.8 cmh)		290 cfh (8.2 cmh)
3/4 in. x 3/4 in.	200 cfh (5.7 cmh)	30 cfh (0.8 cmh)		300 cfh (8.5 cmh)

^a Capacity based on 1000 Btu/cu ft, 0.64 specific gravity natural gas at 1 in. wc pressure drop (37.3 MJ/cu m, 0.64 specific gravity natural gas at 0.25 kPa pressure drop).

Use conversion factors in Table 3 to convert capacities for other gases.

Table 3. Gas Capacity Conversion Factors.

Gas	Specific Gravity	Multiply Listed Capacity By
Manufactured	0.60	0.516
Mixed	0.70	0.765
Propane	1.53	1.62

Body Pattern:

Straight-through body pattern.

Inlet x Outlet Sizes Available:

1/2 x 1/2 in., 1/2 x 3/4 in., and 3/4 x 3/4 in.

Adapters:

Adapters available for 1/2 and 3/4 in. straight and angle connections. Refer to Table 4.

Electrical Voltage:

Voltage and Frequency: 24 Vac, 50/60 Hz. Current Draw: 0.70A.

Table 1. Temperature Range and Regulatory Type.

Model Number	Ambient Temperature Range		Regulatory Type
	°F	°C	
VR8300A	0° to 175°	18° to 79°	Standard-opening
VR8300M	-40° to 175°	-40° to 79°	Standard-opening

Table 2. Capacity

Table 4. Flange Part Numbers.

Inlet/Outlet Pipe Size	Flange Type	Part Number ^{a, b}	
		Without Hex Wrench	With Hex Wrench
1/2 in. NPT	Elbow		393690-13
3/4 in. NPT	Straight	393690-4	

^a Flange kits include one flange with attached O-ring and fan mounting screw.

^b Do not use flanges on gas controls with 3/4 inch inlet and 3/4 inch outlet. On models with 1/2 inch inlet and 3/4 inch outlet, use flanges only on the 1/2 inch inlet side.

Approvals:

CSA 112395



INSTALLATION

When Installing this Product...

1. Read these instructions carefully. Failure to follow them could damage the product or cause a hazardous condition.
2. Check the ratings given in the instructions and on the product to make sure the product is suitable for your application.
3. Installer must be a trained, experienced service technician.
4. After installation is complete, check out product operation as provided in these instructions.

! WARNING

Fire or Explosion Hazard.

Can cause property damage, severe injury, or death.

Follow these warnings exactly:

1. Disconnect power supply before installing or servicing.
2. To avoid dangerous accumulation of fuel gas, turn off gas supply at the appliance service valve before starting installation, and perform Gas Leak Test after completion of installation.
3. Do not bend pilot tubing within 3" of the gas control or pilot burner after compression fitting has been tightened, or gas leakage at the connection may result.
4. Always install sediment trap in gas supply line to prevent contamination of gas control.
5. Do not force gas control knob. Force or attempted repair may result in fire or explosion. Use only your hand to push down the reset button or turn the gas control knob. Never use any tools. If the gas control knob or reset button does not operate by hand, the gas control should be replaced by a qualified service technician.

! CAUTION

Equipment Hazard.

Improper installation can burn out thermostat heat anticipator.

Do not apply a jumper across or short the valve coils.

IMPORTANT

These gas controls are shipped with protective seals over inlet and outlet tappings. Do not remove seals until ready to connect piping.

Follow the appliance manufacturer instructions if available; otherwise, use the instructions provided below.

Converting Between Natural Gas and LP Gas

If needed, convert valve between Natural and LP gas.

! WARNING

Fire or Explosion Hazard.

Can cause property damage, severe injury, or death.

1. Do not use a gas control set for natural gas on LP gas or a gas control set for LP gas on natural gas.
2. When making the conversion, the main and pilot burner orifices **MUST** be changed to meet the specifications of the appliance manufacturer.

Standard or slow-opening gas controls can be converted from one gas to another. To convert from natural gas to LP, use the 393691 LP Conversion Kit. To convert from LP to natural gas, use the 394588 Natural Gas Conversion Kit. Step-opening gas controls cannot be converted.

To convert the control from one gas to another:

1. Turn off the main gas supply to the appliance.
2. Remove the regulator cap screw and pressure regulator adjusting screw. See Fig. 1.
3. Remove the existing spring.
4. Insert the replacement spring with the tapered end down. See Fig. 2.
5. Install the new plastic pressure regulator adjustment screw so that the top of the screw is flush (level) with the top of the regulator. Turn the pressure regulator adjustment screw clockwise six complete turns. This provides a preliminary pressure setting of about 10.0 in. wc (2.5 kPa) for an LP regulator and a 3.5 in. wc (0.9 kPa) for a natural gas regulator.
6. Check the regulator setting with a manometer or by clocking the gas meter after gas control is installed. See the Startup and Checkout section.
7. Install the new cap screw.
8. Mount the conversion label on the control.

Install the control according to the appliance manufacturer instructions.

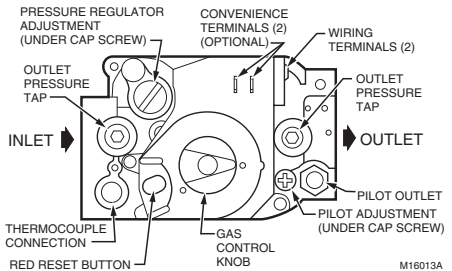

Fig. 1. Top view of gas control.

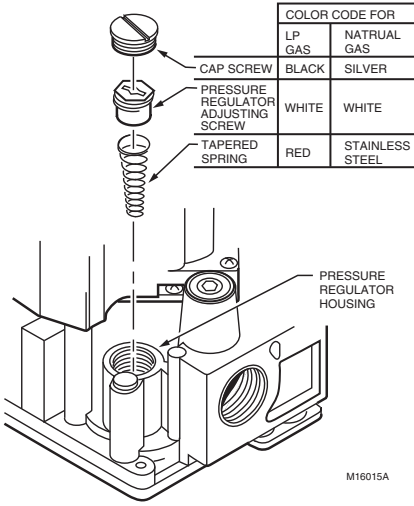

Fig. 2. Install conversion kit in regulated gas control.

Install Adapters to Gas Control

If installing adapters on the gas control, mount them as shown in Fig. 2:

Flanges:

1. Choose the appropriate flange for your application.
2. Remove the seal over the gas control inlet or outlet.
3. Ensure the O-ring is fitted into the groove of the flange. If the O-ring is not attached or is missing, do not use the flange.
4. With the O-ring facing the gas control, align the screw holes on the gas control with the holes in the flange. Insert and tighten the screws provided with the flange. See Fig. 3. Tighten the screws to 25 in. lb of torque to provide a gas-tight seal.

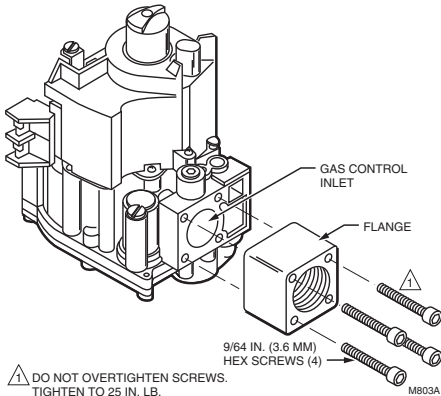

⚠ DO NOT OVERTIGHTEN SCREWS. TIGHTEN TO 25 IN. LB.

Fig. 3. Install flange to gas control.

Bushings:

1. Remove the seal over the gas control inlet or outlet.

IMPORTANT

On LP installations, use a compound resistant to LP gas. Do not use Teflon tape.

2. Apply moderate amount of good quality pipe compound to bushing, leaving two end threads bare.
3. Insert bushing in gas control and thread pipe carefully into bushing until tight.

Follow the instructions below for piping, installing control, connecting pilot tubing, thermocouple and wiring. Make certain the leak test you perform on the control after completing the installation includes leak testing the adapters and screws. If you use a wrench on the valve after flanges are installed, use the wrench only on the flange, not the control.

USE ADAPTERS TO SOLVE SWING RADIUS PROBLEMS

In some field service applications, it is difficult or impossible to thread the gas control onto the gas supply pipe because of space limitations. This problem can usually be resolved by using an adapter. The adapter is installed on the end of the supply pipe in place of the gas control, following the same precautions and instructions that are used for installing the gas control. After the adapter is installed, the gas control is attached to the adapter as outlined above. Note that using an adapter increases the overall length of the gas control.

Choose Gas Control Location

Do not locate the gas control where it can be affected by steam cleaning, high humidity, dripping water, corrosive chemicals, dust or grease accumulation, or excessive heat. To ensure proper operation, follow these guidelines:

- Locate gas control in a well ventilated area.
- Mount gas control high enough above the cabinet bottom to avoid exposure to flooding or splashing water.
- Make sure the ambient temperature does not exceed the ambient temperature ratings for each component.
- Cover gas control if appliance is cleaned with water, steam, or chemicals or to avoid dust and grease accumulation.
- Avoid locating gas control where exposure to corrosive chemical fumes or dripping water is likely.

Locate the gas control in the appliance vestibule on the gas manifold. In replacement applications, locate the gas control in the same location as the old gas control.

Install Piping to Gas Control

All piping must comply with local codes and ordinances or with the National Fuel Gas Code (ANSI Z223.1 NFPA No. 54), which ever applies. Tubing installation must comply with approved standards and practices.

1. Use new, properly reamed pipe free from chips. If tubing is used, make sure the ends are square, deburred and clean. All tubing bends must be smooth and without deformation.
2. Run pipe or tubing to the gas control. If tubing is used, obtain a tube-to-pipe coupling to connect the tubing to the gas control.

3. Install sediment trap in the supply line to the gas control. See Fig. 4.

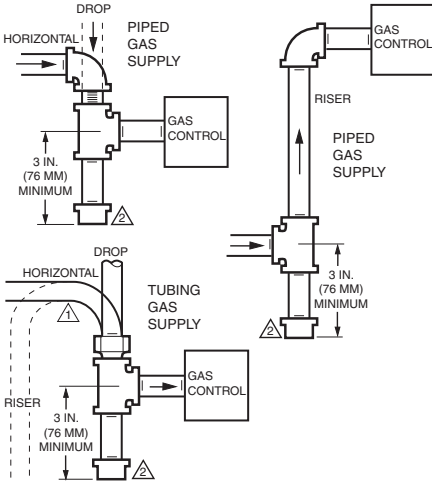

⚠ ALL BENDS IN METALLIC TUBING SHOULD BE SMOOTH.

⚠ CAUTION: SHUT OFF THE MAIN GAS SUPPLY BEFORE REMOVING END CAP TO PREVENT GAS FROM FILLING THE WORK AREA. TEST FOR GAS LEAKAGE WHEN INSTALLATION IS COMPLETE. M3077B

Fig. 4. Sediment trap installation.

IMPORTANT

On LP installations, use compound resistant to LP gas. Do not use Teflon tape.

4. Apply a moderate amount of good quality pipe compound (DO NOT use Teflon tape) to pipe only, leaving two end threads bare. On LP installations, use compound resistant to LP gas.
5. Remove seals over the gas control inlet and outlet if necessary.
6. Connect the pipe to the gas control inlet and outlet. Use a wrench on the square ends of the gas control. If an adapter is used, place the wrench on the adapter rather than the gas control. Refer to Fig. 1 and 6.

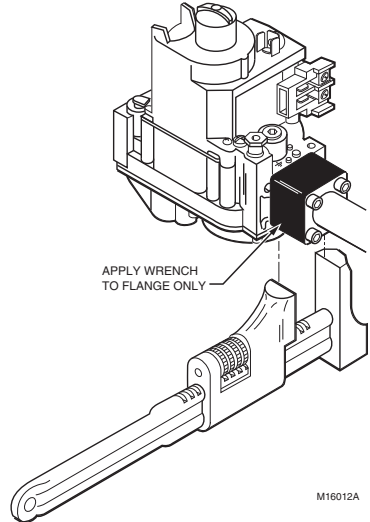

Fig. 6. Proper use of wrench on gas control.

Install Gas Control

To install:

1. Mount the gas control 0 to 90 degrees, in any direction, from the upright position of the gas control knob, including vertically.
2. Mount the gas control so the gas flow is in the direction of the arrow on the bottom of the gas control.
3. Thread pipe the amount shown in Table 5 for insertion into the gas control. Do not thread pipe too far. Valve distortion or malfunction can result if the pipe is inserted too deeply into the gas control. See Fig. 5.

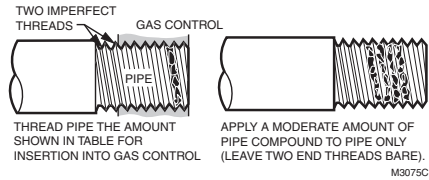

Fig. 5. Use moderate amount of pipe compound.

Table 5. NPT Pipe Thread Length in in.

Pipe Size	Thread Pipe this Amount	Maximum Dept Pipe can be Inserted into Control
3/8 in.	9/16 in.	3/8 in.
1/2 in.	3/4 in.	1/2 in.
3/4 in.	13/16 in.	3/4 in.

Connect Pilot Gas Tubing

1. Cut tubing to desired length and bend as necessary for routing to pilot burner. Do not make sharp bends or deform the tubing. Do not bend tubing within 3 inches of the gas control or pilot burner after compression fitting is tightened, because this can result in gas leakage at the connection.
2. Square off and remove the burrs from the end of the tubing.
3. Unscrew the compression fitting from the pilot outlet (Fig. 1). Slip the compression fitting over the tubing and slide out of the way.

NOTE: When replacing a gas control, cut off the old compression fitting and replace with the new compression fitting provided on the gas control. Never use the old compression fitting as it may not provide a gas-tight seal.

4. Push tubing into the pilot gas tapping on the outlet end of the control until it bottoms. While holding the tubing all the way in, slide the compression fitting into place and engage threads—turn until finger-tight. Then tighten one more turn with wrench. Do not overtighten. Refer to Fig. 7.

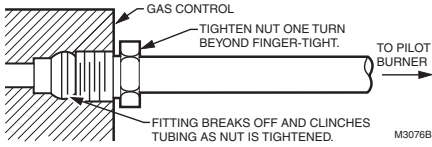

Fig. 7. Always use new compression fitting.

5. Connect other end of tubing to pilot burner according to pilot burner manufacturer instructions.

Install Thermocouple

The Q340A Thermocouple (with adapters) is provided with some models of the VR8300. Install the Q340A as follows:

1. Determine if the pilot burner requires a thermocouple with a push-in clip or attachment nut, and attach the correct adapter to the Q340.
2. For push-in clip type pilot burners, from beneath, insert the tip of the Q340 into the hole or barrel of the pilot burner. Push in firmly to lock in place.
3. For attachment nut type pilot burners: From beneath, insert the tip of the Q340 into the hole or barrel in the pilot burner. Engage the threads of the attachment nut and tighten securely.

If a supplementary limit or energy cutoff (ECO) is used, insert the ECO connector (order part no. 394332 as shown in Fig. 8) and then connect the thermocouple lead. Otherwise, insert the thermocouple lead directly.

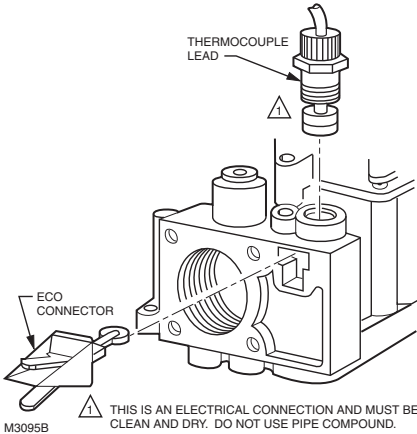

Fig. 8. Install thermocouple, optional ECO connector to power unit.

Table 6. Maximum Length of Supplementary Limit Leadwires in in. (m) When Using Q340A Thermocouple.

Thermocouple Length		Maximum Leadwire Length x 2 (Wires)					
		AWG No. 14		AWG No. 16		AWG No. 18	
in.	in.	in.	in.	in.	in.	in.	in.
18	0.5	35	0.9	22	0.6	13	0.3
24	0.6	29	0.7	18	0.5	11	0.3
30	0.8	23	0.6	15	0.4	9	0.2
36	0.9	17	0.4	11	0.3	6	0.3
48	1.2	DO NOT USE					
60	1.5						

This is an electrical connection and must be clean and dry. Never use pipe compound. Tighten only 1/4 turn beyond finger-tight to give good electrical continuity. Do not overtighten.

Wiring

CAUTION
Hazardous Voltage.
Can cause personal injury or equipment damage.
 Disconnect power supply before installing or servicing.

All wiring must comply with applicable electrical codes and ordinances.

Refer to the appliance manufacturer instructions if available, or use the following procedure.

1. Check the power supply rating on the gas control and make sure it matches the available supply. Install the transformer, thermostat, and other controls as required.
2. Connect the control circuit to the gas control terminals. See Fig. 1 and 9.

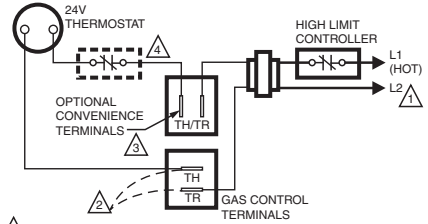

1. POWER SUPPLY. PROVIDE DISCONNECT MEANS AND OVERLOAD PROTECTION AS REQUIRED.
2. DO NOT JUMPER THESE TERMINALS. THIS SHORTS VALVE COIL AND CAN BURN OUT ANTICIPATOR IN THERMOSTAT.
3. CONVENIENCE TERMINALS SERVE ONLY AS A TIE POINT. THEY ARE NOT INTERNALLY WIRED TO THE CONTROL CIRCUIT OR TO GROUND.
4. OPTIONAL HIGH LIMIT.

Fig. 9. Wiring connections for 24V control.

3. Adjust the thermostat heat anticipator to the 0.70 rating stamped on valve operator.

Table 7. Maximum Length of Supplementary Limit Leadwires in in. (m) When Using Q390/Q340 Thermocouple.

Thermocouple Length		Maximum Leadwire Length x 2 (Wires)					
		AWG No. 14		AWG No. 16		AWG No. 18	
in.	m.	in.	m.	in.	m.	in.	m.
12	0.3	47	1.2	30	0.8	18	0.5
18	0.5	41	1.0	26	0.7	16	0.4
24	0.6	35	0.6	22	0.6	14	0.4
30	0.8	29	0.8	18	0.5	11	0.3
36	0.9	23	0.6	15	0.4	9	0.2
40	1.0	19	0.5	12	0.3	7	0.2
48	1.2	11	0.3	7	0.2		
60	1.5	DO NOT USE					

START-UP AND CHECKOUT

⚠ WARNING

Fire or Explosion Hazard.

Can cause property damage, severe injury, or death.

- Do not force the gas control knob. Use only your hand to push down the reset button or turn the gas control knob. Never use any tools.
- If the gas control knob or reset button does not operate by hand, or if the reset button stays depressed after it is released, the gas control should be replaced by a qualified service technician.

Gas Control Knob Settings

The gas control knob has three settings:

- OFF: prevents pilot and main burner gas flow.
- PILOT: permits pilot gas flow only. Gas control knob must be held depressed or thermocouple must be heated sufficiently to hold the safety control valve open.
- ON: permits main burner and pilot gas flow. Gas control and thermostat controls the main burner gas flow.

NOTE: Gas controls are shipped with the gas control knob in the ON position.

Perform Gas Leak Test

⚠ WARNING

Fire or Explosion Hazard.

Can cause property damage, severe injury, or death





Check for gas leaks with rich soap and water solution any time work is done on a gas control.

Gas Leak Test

- Paint the pipe connections upstream of the gas control with a rich soap and water solution. Bubbles indicate a gas leak.
- If a leak is detected, tighten the pipe connection.
- Stand clear while lighting the main burner to prevent injury caused from hidden gas leaks that could cause flashback in the appliance vestibule. Light the main burner.

- With the main burner in operation, paint pipe joints (including adapters) and gas control inlet and outlet with rich soap and water solution.
- If another leak is detected, tighten the adapter screws, joints, and pipe connections.
- Replace the part if gas leak cannot be stopped.



Light Pilot Burner Flame

- Turn the gas control knob clockwise  to OFF. Wait five minutes to dissipate any unburned gas. Sniff around the appliance near the floor. Do not relight the pilot flame if you smell gas.
- Turn the gas control knob counterclockwise  to PILOT. Push down and hold the gas control knob while lighting the pilot flame.
- Hold the gas control knob down about one minute, then release.
 - If the pilot flame goes out, turn the gas control knob clockwise  to OFF and repeat steps 1 through 3.
 - If pilot flame remains lit, turn the gas control knob counterclockwise  to ON.

Adjust Pilot Burner Flame

The pilot flame should envelop 3/8 to 1/2 in. (10 to 13 mm) of the thermocouple tip. See Fig. 10.

To adjust the pilot flame:

- Remove the pilot adjustment cover screw. See Fig. 1.
- Turn the inner adjustment screw clockwise  to decrease or counterclockwise  to increase the pilot flame.
- Always replace the cover screw after adjustment and tighten firmly to ensure proper operation.

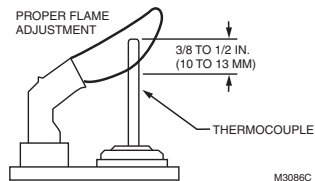

Fig. 10. Proper flame adjustment.

Light Main Burner

Follow the appliance manufacturer instructions or set the thermostat setpoint 10°F (6°C) above the room temperature to call for heat.

CAUTION

- Do not exceed the input rating stamped on the appliance nameplate, or the manufacturer recommended burner orifice pressure for the size orifice(s) used. Make sure the main burner primary air supply is properly adjusted for complete combustion. Follow the instructions of the appliance manufacturer.
- IF CHECKING GAS INPUT BY CLOCKING THE GAS METER:**
 - Be sure there is no gas flow through the meter other than that of the appliance being tested.
 - Other appliances must remain off with pilots extinguished (or the consumptions must be deducted from the meter reading).
 - Convert the flow rate to Btuh as described in the Gas Controls Handbook, form 70-2602, and compare to the Btuh input rating on the appliance name plate.
- IF CHECKING GAS INPUT WITH A MANOMETER (PRESSURE GAUGE):**
 - Make sure the gas control knob is in the PILOT position before removing the outlet pressure tap plug to connect the manometer.
 - Turn the gas control knob back to PILOT when removing the manometer and replacing outlet pressure tap plug.
 - Shut off the gas supply at the appliance service valve or, for LP gas, at the gas tank before removing the outlet pressure tap plug, and before disconnecting the manometer and replacing the outlet pressure tap plug.

• Perform the Gas Leak Test at the inlet pressure tap plug.

Standard-Opening and Slow-Opening Pressure Regulator

- The gas control outlet pressure should match the manifold pressure listed on the appliance nameplate.
- With the main burner operating, check the gas control flow rate using the meter clocking method or check the gas pressure using a manometer connected to the gas control outlet pressure tap. See Fig. 1.
- If necessary, adjust the pressure regulator to match the appliance rating. Refer to Table 7 or 8 for the factory-set nominal outlet pressures and adjustment ranges.
 - Remove the pressure regulator adjustment cap and screw.
 - Use a screwdriver to turn the inner adjustment screw  clockwise to increase or counter-clockwise to decrease the main burner gas pressure.
 - Always replace the cap screw and tighten firmly to ensure proper operation.
- If the desired outlet gas pressure or gas flow rate cannot be achieved by adjusting the gas control, check the gas control inlet pressure using a manometer at the inlet pressure tap. If the inlet pressure is in the normal range (refer to Table 7 or 8), replace the gas control. Otherwise, take the necessary steps to provide proper gas pressure to the gas control.

Table 8. Pressure Regulator Specification Pressures in in. wc.

Model	Type of Gas	Nominal Inlet Pressure Range	Outlet Pressure			
			Nominal Factory Setting		Setting Range	
			Step	Full Range	Step	Full Rate
Standard-opening	Natural	5.0 - 7.0	—	3.5	—	3.0 - 5.0
	Lp	12.0 - 14.0	—	11.0	—	8.0 - 12.0

Table 9. Pressure Regulator Specification Pressures in Kpa.

Model	Type of Gas	Nominal Inlet Pressure Range	Outlet Pressure			
			Nominal Factory Setting		Setting Range	
			Step	Full Range	Step	Full Rate
Standard-opening	Natural	1.2 - 1.7	—	0.9	—	0.7 - 1.2
	Lp	2.9 - 3.9	—	2.7	—	2.0 - 3.0

CHECK SAFETY SHUTDOWN PERFORMANCE

WARNING

Fire or Explosion Hazard.
Can cause property damage, severe injury, or death
 Perform the safety shutdown test any time work is done on a gas system.

- Place the gas control knob in the PILOT position. Main burner should go off and pilot should remain lit.
- Extinguish the pilot flame. Pilot gas flow should stop within 2-1/2 minutes. Safety shutoff of pilot gas proves complete shutdown since safety shutoff valve prevents main burner and pilot gas flow.
- Relight pilot burner and operate system through one complete cycle to ensure all controls operate properly.

MAINTENANCE



WARNING

Fire or Explosion Hazard.

Can cause property damage, severe injury, or death.

Improper cleaning or reassembly can cause gas leakage. When cleaning, ensure that control is reassembled properly and perform gas leak test.

Regular preventive maintenance is important in applications that place a heavy load on system controls such as in the commercial cooking and agricultural and industrial industries because:

- In many such applications, particularly commercial cooking, the equipment operates 100,000-200,000 cycles per year. Such heavy cycling can wear out the gas control in one to two years.
- Exposure to water, dirt, chemicals and heat can damage the gas control and shut down the control system.

The maintenance program should include regular check-out of the gas control as outlined in the Startup and Checkout section, and the control system as described in the appliance manufacturer literature.

Maintenance frequency must be determined individually for each application. Some considerations are:

- Cycling frequency. Appliances that may cycle 100,000 times annually should be checked monthly.
- Intermittent use. Appliances that are used seasonally should be checked before shutdown and again before the next use.
- Consequence of unexpected shutdown. Where the unexpected shutdown is costly, the system should be checked more often.
- Dusty, wet, or corrosive environment. In these environments the gas control can deteriorate more rapidly so the system should be checked more often.

The gas control should be replaced if:

- It does not perform properly on checkout or troubleshooting.
- The gas control knob is hard to turn or push down, or it fails to pop up when released.
- The gas control is likely to have operated for more than 200,000 cycles.

SERVICE



WARNING

Fire or Explosion Hazard.

Can cause property damage, severe injury or death

Do not disassemble the gas control; it contains no replaceable components. Attempted disassembly or repair can damage the gas control.



CAUTION

Hazardous voltage.

Improper installation can burn out thermostat heat anticipator.

Do not apply a jumper across or short the valve coil terminals.

IMPORTANT

Allow 60 seconds after shutdown before re-energizing step-opening model to ensure light off at step pressure.

If Pilot Burner Flame does not Light:

1. Make sure that the main gas supply valve is open and the pilot gas supply line is purged of air.
2. Light the pilot burner flame following procedures in Light the Pilot Burner Flame section. If pilot burner flame does not light:
 - a. Check the pilot gas adjustment screw. If closed, readjust the pilot flame. Refer to Adjust the Pilot Burner Flame section.
 - b. Perform the Gas Leak Test at the compression fitting. If a gas leak is detected, replace the old compression fitting or tighten the newly installed one. See Fig. 1.
 - c. Make sure that the pilot burner tubing or pilot burner orifice is not clogged.

If Pilot Burner Flame Goes Out when Gas Control Knob is Released:

1. Make sure the gas control knob is held in at least one minute to allow the thermocouple time to heat.
2. Check the pilot burner flame adjustment. Refer to Adjust the Pilot Burner Flame section.
3. Check the wiring between the thermocouple and the gas control valve operator.
4. Make sure that the thermocouple connection to the power unit is tightened 1/4 turn beyond finger tight.
5. If pilot burner flame goes out, measure the open-circuit thermocouple output voltage. Compare it to the acceptable range charts in the thermocouple specifications or in the Gas Controls Handbook. Replace the thermocouple if voltages are outside the acceptable range.
6. Check the power unit resistance. If it is above 11 ohms, replace the gas control.

If Main Burner does not Come on with Call For Heat:

1. Make sure the gas control knob is in the ON position.
2. Adjust the thermostat several degrees above the room temperature.
3. Use an ac voltmeter to measure the voltage across terminals TH and TR. If:
 - a. No voltage is present, check the control circuit for proper operation.
 - b. 24 Vac is present, but first operator did not click open, check for excessive inlet gas pressure. If inlet gas pressure is correct, replace the gas control.
4. Measure the closed thermocouple output voltages and compare to the acceptable range charts in the thermocouple specifications or in the Gas Controls Handbook. Replace the thermocouple if voltages are outside the acceptable range.

If Main Burner is Over firing:

Adjust the gas control pressure regulator to the correct pressure. If the regulator cannot be adjusted and supply pressure is in the normal range, replace the gas control.

Instructions to the Homeowner

WARNING

Fire or Explosion Hazard.

Can cause property damage, severe injury, or death.

Follow these warnings exactly:

1. Pilot burner flame must be lit manually. Follow these instructions exactly.
2. Before lighting pilot burner flame, smell around the appliance area for gas. Be sure to smell next to floor because LP gas is heavier than air.
3. IF YOU SMELL GAS:
 - Immediately turn off the gas supply at the appliance service valve. On LP gas systems, turn off the gas supply at the gas tank.
 - Do not light any appliances in the house.
 - Do not touch electrical switches or use the phone.
 - Leave the building and call your gas supplier.
 - If you can not reach your gas supplier, call the fire department.
4. Do not force the gas control knob on the appliance. Use only your hand to turn the gas control knob. Never use any tools. If the gas control knob does not operate by hand, have a qualified service technician replace the control. Force or attempted repair can result in a fire or explosion.
5. The gas control is a safety device, it must be replaced in case of any physical damage such as bent terminals, missing or broken parts, stripped threads, or evidence of exposure to heat.

IMPORTANT

Follow the operating instructions provided by the manufacturer of your heating appliance. The information below is for a typical gas control application, but the specific controls used and the procedures outlined by the manufacturer or your appliance may differ, requiring special instructions.

Lighting the Pilot Burner Flame



STOP: READ THE WARNING ABOVE.

The pilot burner flame must be lit manually. If the pilot burner flame has gone out, follow these instructions exactly.

1. Set the thermostat to its lowest setting.
2. Disconnect all electric power to the appliance.

3. Remove the gas control access panel.
4. Push in the gas control knob slightly and turn clockwise  to OFF.

NOTE: The gas control knob cannot be turned from PILOT to OFF unless it is pushed in slightly. Do not force the gas control knob.

5. Wait five minutes to clear out any unburned gas. If you then smell gas, STOP! Follow the instructions in step 3, IF YOU SMELL GAS section, in the Warnings listed. If you do not smell gas, continue with the next step.
6. Remove the pilot burner access panel located below and behind the gas control.
7. Find the pilot burner by following the metal tube from the gas control. The pilot burner is between the two burner tubes behind the pilot burner access panel.
8. Turn the gas control knob counterclockwise  to PILOT.
9. Push and hold the gas control knob all the way in. Immediately light the pilot burner flame with a match and continue holding in the gas control knob for one minute after the pilot burner flame is lit.
10. Release the gas control knob until it pops back up. The pilot burner flame should remain lit. If pilot burner flame goes out, repeat steps 1 through 10.
 - a. If the gas control knob does not pop up when released, stop immediately and call your service technician or gas supplier.
 - b. If the pilot flame does not stay lit after several attempts, turn the gas control knob to OFF and call your service technician or gas supplier.
11. Turn the gas control knob counterclockwise  to ON.
12. Replace the pilot burner access panel.
13. Replace the gas control access panel.
14. Reconnect all electric power to the appliance.
15. Set the thermostat to the desired setting.

Turning Off Appliance

Vacation Shutdown: Set the thermostat to the desired room temperature while you are away.

Complete Shutdown: Push the gas control knob in slightly and turn clockwise  to OFF. Do not force. Appliance completely shuts off. Follow the steps in Lighting the Pilot Burner Flame section to resume normal operation.



Resideo Technologies, Inc.
1985 Douglas Drive North, Golden Valley, MN 55422
1-800-468-1502

www.resideo.com 69-0668-05 M.S. Rev. 06-20 | Printed in United States