



BDV Series Monessen Direct Vent Gas Fireplace

Installation and Operating Instructions

MODELS:

BDV300, BDV400, BDV500, BDV600

WARNINGS

IF THE INFORMATION IN THESE INSTRUCTIONS ARE NOT FOLLOWED EXACTLY, A FIRE OR EXPLOSION MAY RESULT CAUSING PROPERTY DAMAGE, PERSONAL INJURY OR LOSS OF LIFE.

- Do not store or use gasoline or other flammable vapors and liquids in the vicinity of this or any other appliance.
- **WHAT TO DO IF YOU SMELL GAS**
 - Do not try to light any appliance.
 - Do not touch any electrical switch; do not use any phone in your building.
 - Immediately call your gas supplier from a neighbor's phone. Follow the gas supplier's instructions.
 - If you cannot reach your gas supplier, call the fire department.
- Installation and service must be performed by a qualified installer, service agency or the gas supplier.

WARNING: Improper installation, adjustment, alteration, services or maintenance can cause injury or property damage. Refer to this manual. For assistance or additional information consult a qualified installer, service agency or the gas supplier.

This appliance may be installed in an aftermarket*, permanently located, manufactured home (USA only) or mobile home, where not prohibited by local codes.

This appliance is only for use with the type of gas indicated on the rating plate. This appliance is not convertible for use with other gases, unless a certified kit is used.

* Aftermarket: Completion of sale, not for purpose of resale, from the manufacturer.

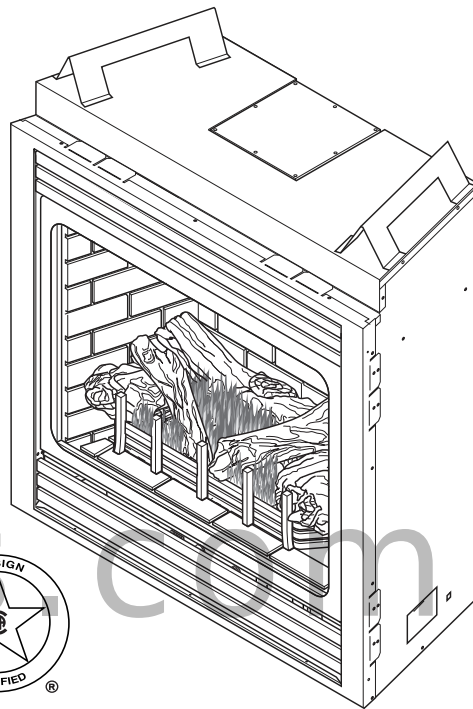

DUE TO HIGH TEMPERATURES, THE APPLIANCE SHOULD BE LOCATED OUT OF TRAFFIC AND AWAY FROM FURNITURE AND DRAPERIES.

CHILDREN AND ADULTS SHOULD BE ALERTED TO THE HAZARDS OF HIGH SURFACE TEMPERATURE AND SHOULD STAY AWAY TO AVOID BURNS OR CLOTHING IGNITION.

YOUNG CHILDREN SHOULD BE SUPERVISED WHEN THEY ARE IN THE SAME ROOM AS THE APPLIANCE.

CLOTHING OR OTHER FLAMMABLE MATERIAL SHOULD NOT BE PLACED ON OR NEAR THE APPLIANCE.

KEEP THE ROOM AREA CLEAR AND FREE FROM COMBUSTIBLE MATERIALS, GASOLINE, AND OTHER FLAMMABLE VAPORS AND LIQUIDS.

READ BEFORE INSTALLING. SAVE THESE INSTRUCTIONS

Important Safety Information	3	Operating Instructions Electronic Ignition ..	37
Product Features	5	What To Do If You Smell Gas	37
Code Approval	5	Lighting Electronic Ignition	37
Pre-Installation Information		To Turn Off Gas	37
Installing Above 2000 Feet	6	Check Gas Pressure Signature Command ..	38
Orifice Sizes, Pressures and BTUs	6	Check Gas Type	38
Before You Install	6	Electrical Wiring	38
Fireplace Framing	7	Optional Fan Blower System	39
Fireplace Dimensions	8	Operating Instructions Signature Command	42
Fireplace Location	9	What to do if You Smell Gas	42
Clearances	10	Operating Instructions	43
Securing Fireplace to Floor or Framing	11	To Turn Gas Off	43
Installation Information	12	Signature Command System	
Vent Installation	13	Operation Instructions	44
Installation Precautions	13	Glass Removal	47
Optional Top Vent Application	14	Final Installation	48
Installation Planning	15	Rockwool Placement	48
Rear (Through the Wall) Applications	18	Log Placement	48
Horizontal Termination Configuration	20	Lava Rock and Ember Placement	48
Below Grade Installation	22	Cleaning and Maintenance	49
Vertical Through-the-Roof Installation	23	Burner, Pilot and Control Compartment	49
Installation for Vertical Termination	24	Pilot Flame	49
Flex Vent Installation	26	Burner Flame	49
Fireplace Installation	28	Vent System	50
Check Gas Type	28	Glass Door	50
Installing Gas Piping to Fireplace/Burner		Logs	50
System Location	28	Rock Wool	50
Checking Gas Pressure Millivolt/Electronic	30	Troubleshooting	51
Electrical Installation	30	Standing Pilot Ignition	51
Electrical Wiring	30	Signature Command System	53
Remote Wall Switch	31	Replacement Parts	54
Electronic Pilot Ignition Wiring	32	Firebox Components	54
Optional Fan Blower System	33	Standing Pilot Engine	56
Operating Instructions Millivolt	34	Electronic IGN Engine	58
What To Do If You Smell Gas	34	Signature Command System	60
Lighting Millivolt Pilot for the First Time	35	Vent Components	62
Lighting Millivolt Pilot	35	Logs	64
Lighting Burner	36	Mass Residents Requirements	65
To Turn Off Gas	36	Warranty	67

INSTALLER

Please leave these instructions with the appliance.

OWNER

Please retain these instructions for future reference.

WARNING

- **Read this owner's manual carefully and completely before trying to assemble, operate, or service this fireplace.**
- **Any change to this fireplace or its controls can be dangerous.**
- **Improper installation or use of this fireplace can cause serious injury or death from fire, burns, explosions, electrical shock and carbon monoxide poisoning.**

This fireplace is a vented product. This fireplace must be properly installed by a qualified service person. The glass door must be properly seated and sealed. If this unit is not properly installed by a qualified service person with glass door properly seated and sealed, combustion leakage can occur.

CARBON MONOXIDE POISONING: Early signs of carbon monoxide poisoning are similar to the flu with headaches, dizziness and/or nausea. If you have these signs, the fireplace may not have been installed properly. Get fresh air at once! Have the fireplace inspected and serviced by a qualified service person. Some people are more affected by carbon monoxide than others. These include pregnant women, people with heart or lung disease or anemia, those under the influence of alcohol, and those at high altitudes.

Propane/LP gas and natural gas are both odorless. An odor-making agent is added to each of these gases. The odor helps you detect a gas leak. However, the odor added to these gases can fade. Gas may be present even though no odor exists.

Make certain you read and understand all warnings. Keep this manual for reference. It is your guide to safe and proper operation of this fireplace.

1. This appliance is only for use with the type of gas indicated on the rating plate. This appliance is not convertible for use with other gases unless a certified kit is used.
2. For propane/LP fireplace, do not place propane/LP supply tank(s) inside any structure. Locate propane/LP supply tank(s) outdoors. To prevent performance problems, do not use propane/LP fuel tank of less than 100 lbs. capacity.
3. If you smell gas
 - shut off gas supply.
 - do not try to light any appliance.

- do not touch any electrical switch; do not use any phone in your building .
- immediately call your gas supplier from a neighbor's phone. Follow the gas supplier's instructions.

4. Never install the fireplace
 - in a recreational vehicle
 - where curtains, furniture, clothing, or other flammable objects are less than 42" from the front, top, or sides of the fireplace
 - in high traffic areas
 - in windy or drafty areas
5. This fireplace reaches high temperatures. Keep children and adults away from hot surfaces to avoid burns or clothing ignition. Fireplace will remain hot for a time after shutdown. Allow surfaces to cool before touching.
6. Carefully supervise young children when they are in the room with fireplace.
7. Do not modify fireplace under any circumstances. Any parts removed for servicing must be replaced prior to operating fireplace.
8. Turn fireplace off and let cool before servicing, installing, or repairing. Only a qualified service person should install, service, or repair the fireplace. Have burner system inspected annually by a qualified service person.
9. You must keep control compartments, burners, and circulating air passages clean. More frequent cleaning may be needed due to excessive lint and dust. Turn off the gas valve and pilot light before cleaning fireplace.

Continued on page 4

Continued from page 3

10. Have venting system inspected annually by a qualified service person. If needed, have venting system cleaned or repaired. See *Cleaning and Maintenance*, page 32.
11. Keep the area around your fireplace clear of combustible materials, gasoline, and other flammable vapor and liquids. Do not run fireplace where these are used or stored. Do not place items such as clothing or decorations on or around fireplace.
12. Do not use this fireplace to cook food or burn paper or other objects.
13. Never place anything on top of fireplace.
14. Do not use any solid fuels (wood, coal, paper, cardboard, etc.) in this fireplace. Use only the gas type indicated on rating plate.
15. This appliance, when installed, must be electrically grounded in accordance with local codes or in the absence of local codes, with the *National Electrical Code, ANSI/NFPA 70*, or the *Canadian Electrical Code, CSA C22.1*.
16. Do not obstruct the flow of combustion and ventilation air in any way. Provide adequate clearances around air openings into the combustion chamber along with adequate accessibility clearance for servicing and proper operation.
17. When the appliance is installed directly on carpeting, tile or other combustible material other than wood flooring, you must set appliance on a metal or wood panel or hearth pad extending the full width and depth of the appliance.
18. Do not use fireplace if any part has been exposed to or has been under water. Immediately call a qualified service person to arrange for replacement of the unit.
19. Do not operate fireplace if any log is broken.
20. Do not use a blower insert, heat exchanger insert, or any other accessory not approved for use with this fireplace.
21. Do not operate the fireplace with glass door removed, cracked, or broken.

IMPORTANT:**PLEASE READ THE FOLLOWING CAREFULLY**

It is normal for fireplaces fabricated of steel to give off some expansion and/or contraction noises during the start up or cool down cycle. Similar noises are found with your furnace heat exchanger or car engine.

IMPORTANT:**PLEASE READ THE FOLLOWING CAREFULLY**

It is not unusual for gas fireplaces to give off some odor the first time it is burned. This is due to the manufacturing process.

Please ensure that your room is well ventilated during burn off — open all windows.

It is recommended that you burn your fireplace for at least ten (10) hours the first time you use it. Place the fan switch in the "OFF" position during this time.

WARNING

Never connect unit to private (non-utility) gas wells. This gas is commonly known as wellhead gas.

NATIONAL
FIREPLACE
INSTITUTE



CERTIFIED
www.nficertified.org

We recommend that our gas hearth products be installed and serviced by professionals who are certified in the U.S. by the National Fireplace Institute® (NFI) as NFI Gas Specialists.

PRODUCT SPECIFICATIONS

- This appliance has been certified for use with either natural or propane gas. See appropriate data plates.
- This appliance is not for use with solid fuels.
- The appliance is approved for bedroom or bedsitting room installations.
- The appliance must be installed in accordance with local codes if any. If none exist use the current installation code. ANSI Z223.1/NFPA 54 in the USA, CSA B149 in Canada.
- This appliance is mobile home approved.
- The appliance must be properly connected to a venting system.
- The appliance is not approved for closet or recessed installations.

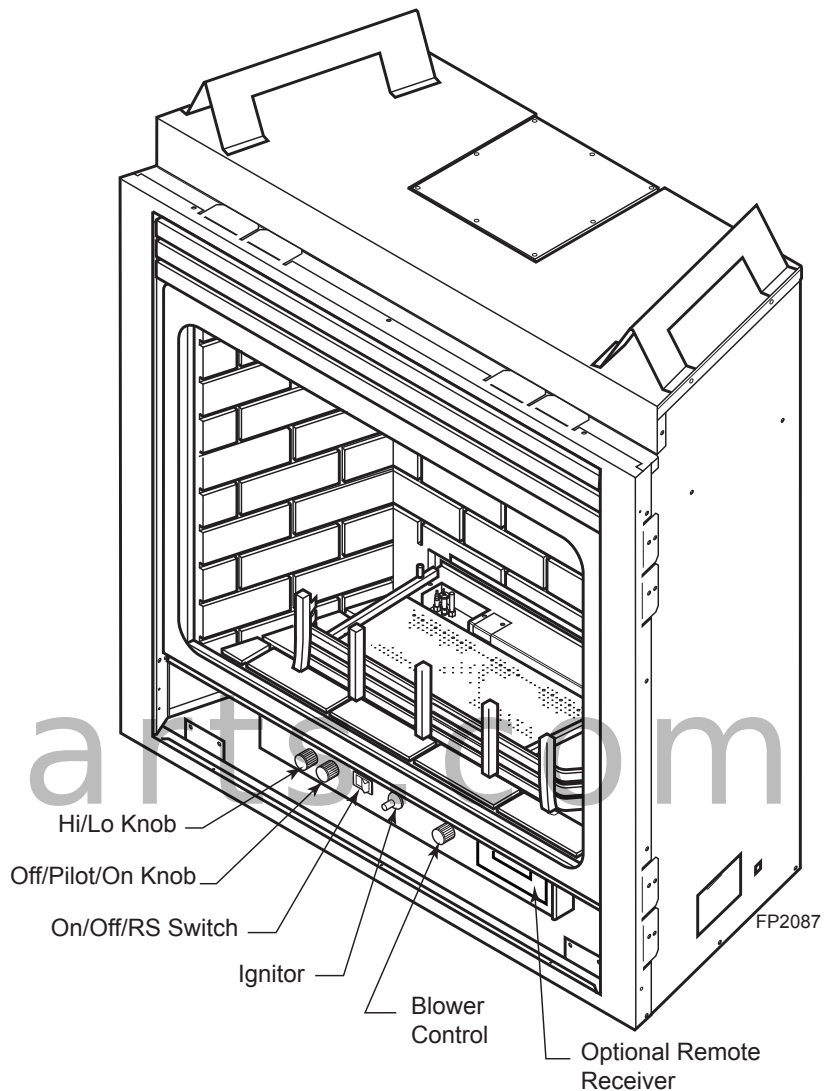

**Figure 1 -
BDV300, 400, 500, 600 Fireplace
(Millivolt Control Shown)**

CODE APPROVAL

Direct Vent type appliances draw all combustion air from outside of the dwelling through the vent pipe. These appliances have been tested by CSA and found to comply with the established standards for DIRECT VENT GAS FIREPLACE HEATERS in the USA and Canada as follows:

LISTED VENTED GAS FIREPLACE HEATER
TESTED TO: ANSI Z21.88b-2008 / CSA 2.33b-2008 STANDARDS

A manufactured home (USA only) or mobile home OEM installation must conform with the **Manufactured Home Construction and Safety Standard, Title 24 CFR, Part 3280**, or when such a standard is not applicable, the **Standard for Manufactured Home Installations, ANSI/NCSBCS A225.1**, or **Standard for Gas Equipped Recreational Vehicles and Mobile Housing, CSA Z240.4**.

HIGH ELEVATIONS

Input ratings are shown in BTU per hour and are certified without deration for elevations up to 4,500 feet (1,370 m) above sea level.

For elevations above 4,500 feet (1,370 m) in USA, installation must be in accordance with the current ANSI Z223.1/NFPA 54 and/or local codes having jurisdiction.

In Canada, please consult provincial and/or local authorities having jurisdiction for installation at elevations above 4,500 feet (1,370 m).

ORIFICE SIZES, PRESSURES AND BTUs**NATURAL GAS**

Manifold Press: (W.C.) 3.5"
 Maximum Supply Pressure 10.5"
 Minimum Supply Pressure 4.5"

PROPANE GAS

Manifold Press: (W.C.) 10"
 Maximum Supply Pressure 13"
 Minimum Supply Pressure 11"

Model Number (Millivolt/Electronic/SCS)	BDV300V/E/S		BDV400V/E/S		BDV500V/E/S		BDV600V/E/S	
	Natural	Propane	Natural	Propane	Natural	Propane	Natural	Propane
Max. Btu/hr Input	21,000	21,000	24,000	24,000	26,000	26,000	26,000	26,000
Min. Btu/hr Input	15,000	15,000	17,000	17,000	20,000	20,000	20,000	20,000
Orifice size	#43	#54	#41	#53	#40	1.55mm	#40	1.55mm

BEFORE YOU START

Read this homeowner manual thoroughly and follow all instructions carefully. Inspect all contents for shipping damage and immediately inform your dealer if any damage is found. Do not install any unit with damaged, incomplete, or substitute parts. Check your packing list to verify that all listed parts have been received. You should have the following:

- Fireplace (Firebox and Burner System)
- Rock Wool
- Log Set

ITEMS REQUIRED FOR INSTALLATION**Tools:**

- Phillips Screwdriver
- Hammer
- Saw and/or saber saw
- Level
- Measuring Tape
- Electric Drill and Bits
- Pliers
- Square
- Pipe Wrench

Building Supplies:

- Framing Materials
- Wall Finishing Materials
- Caulking Material (Noncombustible)
- Fireplace Surround Material (Noncombustible)
- Piping Complying with Local Codes
- Tee Joint
- Pipe Sealant Approved for use with Propane/LPG (Resistant to Sulfur Compounds)

FIREBOX FRAMING

Firebox framing can be built before or after the appliance is set in place. Construct firebox framing following Figure 2 and the chart below for your specific installation requirements. Refer to Page 8, Figure 3 for firebox dimensions. The framing headers may rest on the top of the firebox standoffs. Do not bring headers below top of standoffs.

The firebox may be installed directly on a combustible floor or raised on a platform of an appropriate height. When the firebox is installed directly on carpeting, tile, or other combustible material, other than wood flooring, the firebox shall be installed on a metal or wood panel extending the full width and depth of the enclosure.

WARNING
 Do not fill spaces around firebox with insulation or other materials. This could cause a fire.

	300	400	500	600
A	33 ¹ / ₂ "	37 ¹ / ₂ "	41 ¹ / ₂ "	47 ¹ / ₂ "
B	37 ¹ / ₄ "	40 ⁷ / ₈ "	40 ⁷ / ₈ "	40 ⁷ / ₈ "
C	28 ¹ / ₄ "	29 ¹ / ₄ "	33 ¹ / ₄ "	39 ¹ / ₄ "
D	14 ¹ / ₈ "	14 ⁵ / ₈ "	16 ⁵ / ₈ "	19 ⁵ / ₈ "
E	55 ¹¹ / ₁₆ "	60 ⁷ / ₈ "	64 ⁷ / ₈ "	70 ⁷ / ₈ "
F	27 ¹³ / ₁₆ "	30 ⁷ / ₁₆ "	32 ⁷ / ₁₆ "	35 ⁷ / ₁₆ "
G	13 ³ / ₄ "	15 ³ / ₄ "	15 ³ / ₄ "	15 ³ / ₄ "
H	39 ³ / ₈ "	43 ¹ / ₁₆ "	45 ⁷ / ₈ "	50 ¹ / ₈ "

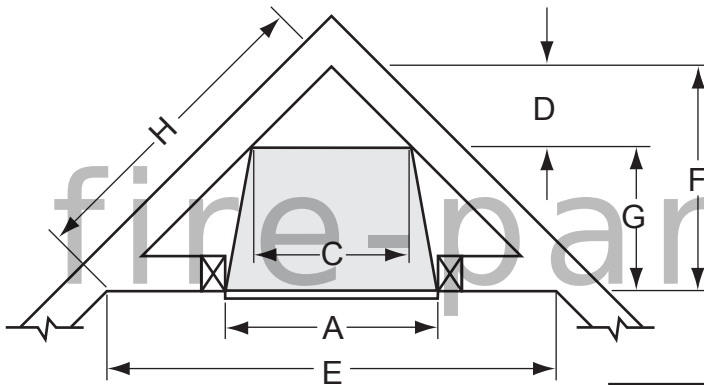

Corner Installation

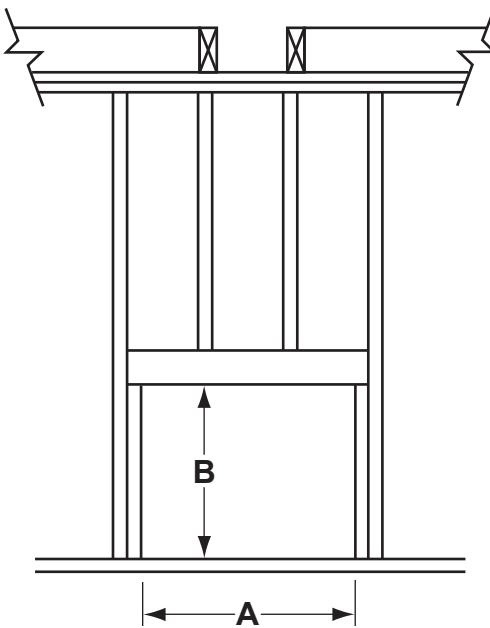

Stud Location

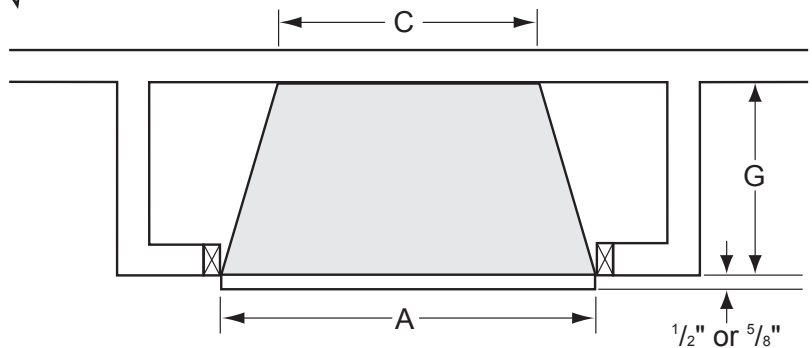

Inside Chase Installation

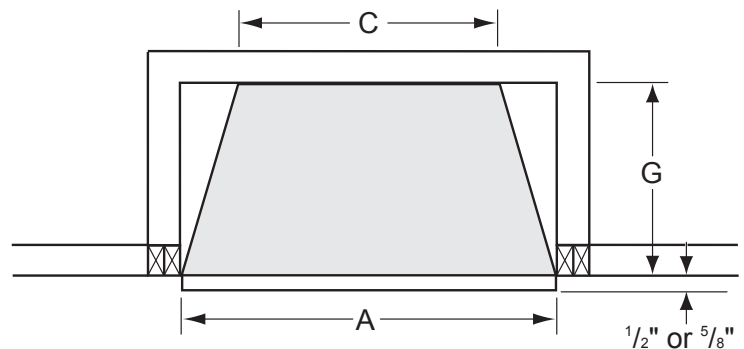

Recessed Installation

Figure 2 - Framing Dimensions

FIREPLACE DIMENSIONS

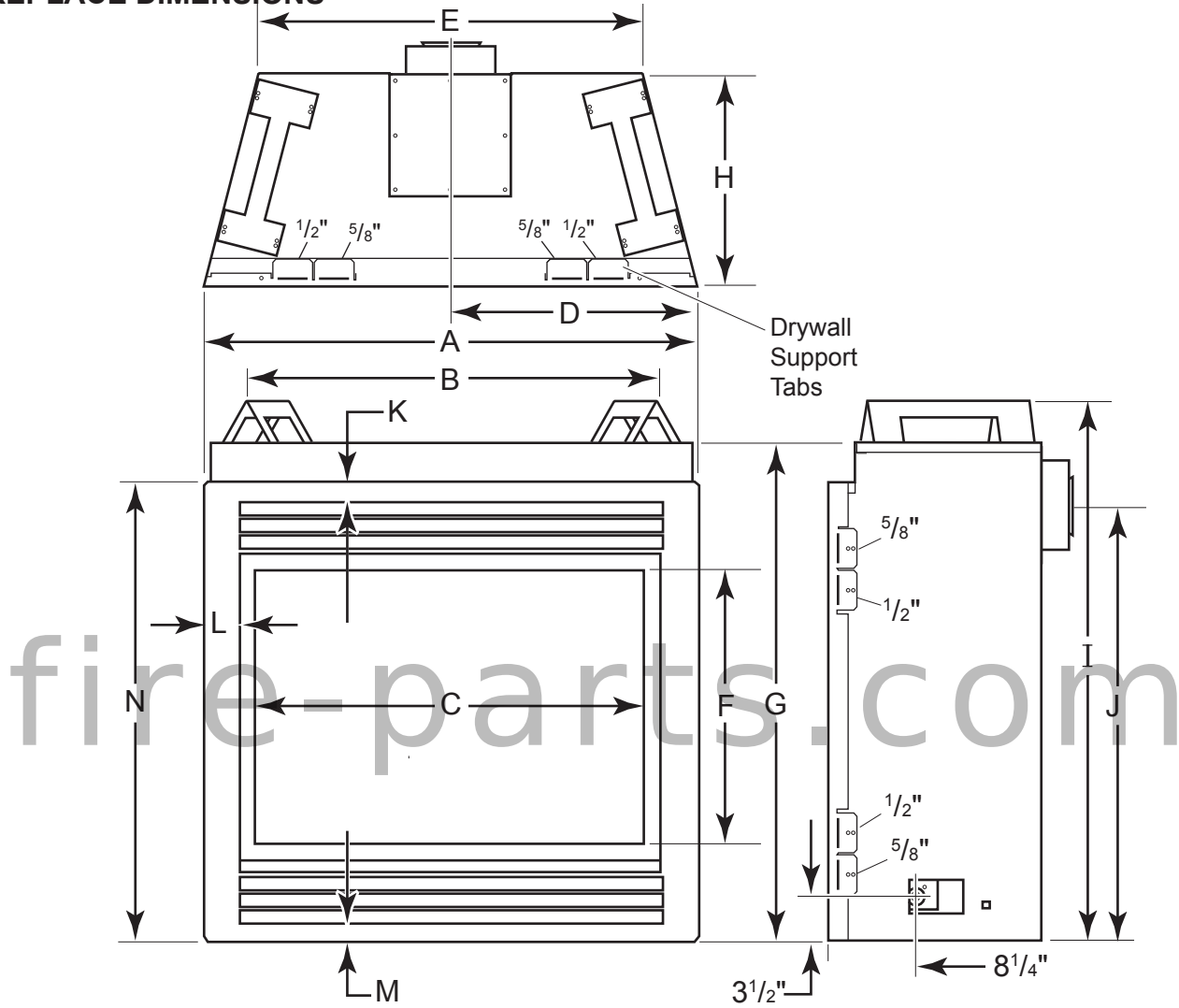

Figure 3 - Fireplace Dimensions

DESCRIPTION	Key Letter	BDV300	BDV400	BDV500	BDV600
Overall Front Width	A	33 ¹ / ₁₆ "	37 ¹ / ₁₆ "	41 ¹ / ₁₆ "	47 ¹ / ₁₆ "
Inside Width	B	29 ⁷ / ₈ "	32"	36"	42"
Glass Width	C	27"	29"	33"	39"
CTR Pipe	D	16 ¹ / ₂ "	18 ¹ / ₂ "	20 ¹ / ₂ "	23 ¹ / ₂ "
Rear Width	E	28"	29"	33"	39"
Glass Height	F	18"	20 ³ / ₈ "	20 ³ / ₈ "	20 ³ / ₈ "
Chassis Height	G	33 ⁷ / ₈ "	37 ¹ / ₂ "	37 ¹ / ₂ "	37 ¹ / ₂ "
Depth	H	14"	16"	16"	16"
Height to Standoffs	I	37"	40 ¹ / ₂ "	40 ¹ / ₂ "	40 ¹ / ₂ "
CTR Height	J	29 ⁵ / ₈ "	33 ¹ / ₈ "	33 ¹ / ₈ "	33 ¹ / ₈ "
Top Face	K	2 ¹ / ₈ "	1 ¹ / ₄ "	1 ¹ / ₄ "	1 ¹ / ₄ "
Side Face	L	1 ¹ / ₂ "	2 ¹ / ₂ "	2 ¹ / ₂ "	2 ¹ / ₂ "
Bottom Face	M	15 ¹ / ₁₆ "	15 ¹ / ₁₆ "	15 ¹ / ₁₆ "	15 ¹ / ₁₆ "
Overall Front Height	N	31 ⁵ / ₈ "	34 ³ / ₄ "	34 ³ / ₄ "	34 ³ / ₄ "

NOTE

COLD CLIMATE INSULATION

If you live in a cold climate, seal all cracks around your appliance, and wherever cold air could enter the room, with noncombustible material. It is especially important to insulate the outside chase cavity between the studs and under the floor on which the appliance rests, if the floor is above ground level.

FIREPLACE LOCATION

Plan for the installation of your appliance. This includes determining where the unit is to be installed, the vent configuration to be used, framing and finishing details, and whether any optional accessories (i.e. blower, wall switch, or remote control) are desired. Consult your local building code agency to ensure compliance with local codes, including permits and inspections.

The following factors should be taken into consideration:

- Clearance to side-wall, ceiling, woodwork, and windows. Minimum clearances to combustibles **must be maintained**.
- This fireplace may be installed along a wall, across a corner, or use an exterior chase. See Figure 4 for suggested locations.
- Location should be out of high traffic areas and away from furniture and draperies due to heat from appliance.
- Never obstruct the front opening of the fireplace.
- Do **not** install in the vicinity where gasoline or other flammable liquids may be stored.
- Vent pipe routing. See *Venting* section found in this manual for allowable venting configurations.
- These units can be installed in a bedroom. See National Fuel Gas Code ANSI Z233.1/NFPA 54 — (current edition), the Uniform Mechanical Code — (current edition), and Local Building Codes for specific installation requirements.

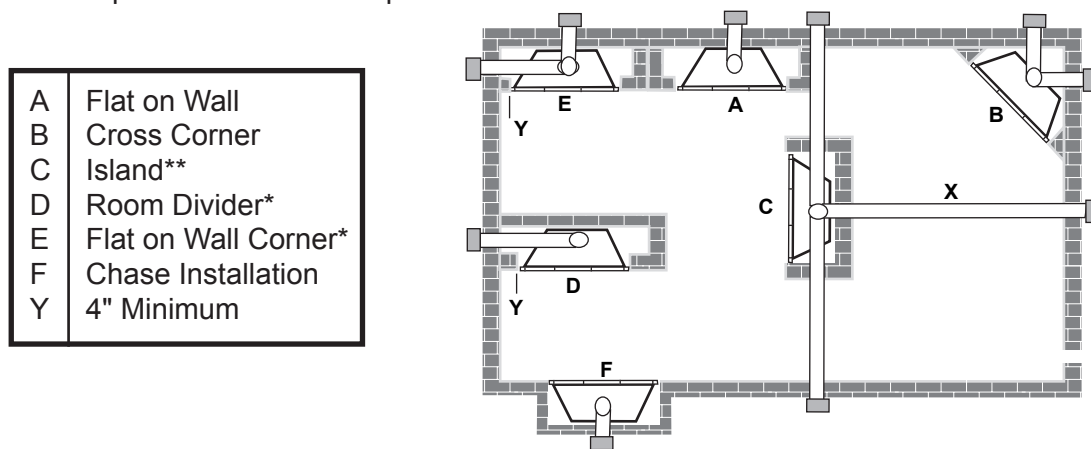

Figure 4 - Locating Gas Fireplace

** Island (C) and room divider (D) installation is possible as long as the horizontal portion of vent system (X) does not exceed 20'. See *Installing Horizontal Termination Configuration* on pages 18 and 19.

* When you install your fireplace in (D) room divider or (E) flat on wall corner positions (Y), a minimum of 6" clearance must be maintained from perpendicular wall and front of fireplace.

CLEARANCES TO COMBUSTIBLES

WARNING

Follow these instructions carefully to ensure safe installation. Failure to follow instructions exactly can create a fire hazard.

The appliance cannot be installed on a carpet, tile or other combustible material other than wood flooring. If installed on carpet or vinyl flooring, the appliance shall be installed on a metal, wood or noncombustible material panel extending full width and depth of the appliance.

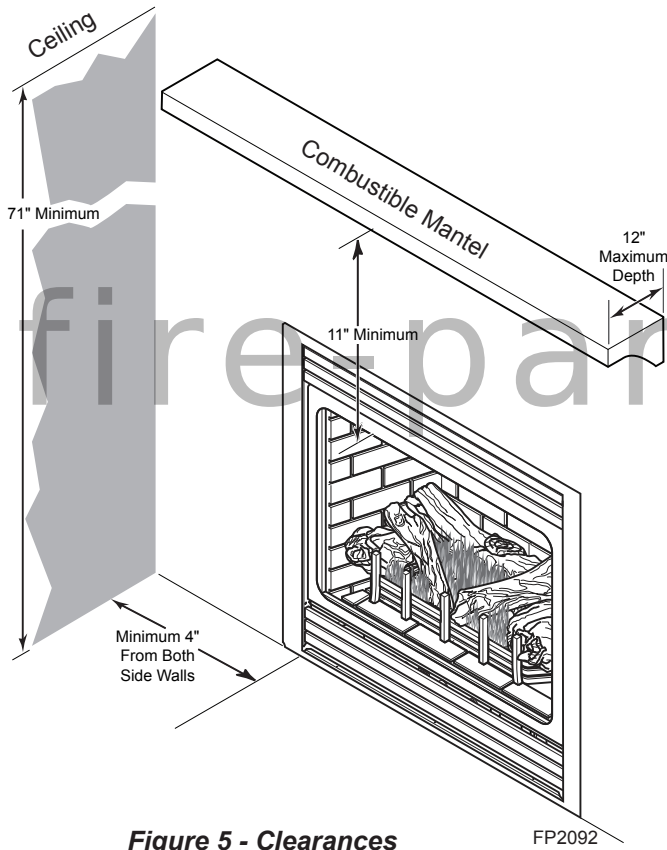

Figure 5 - Clearances

FP2092

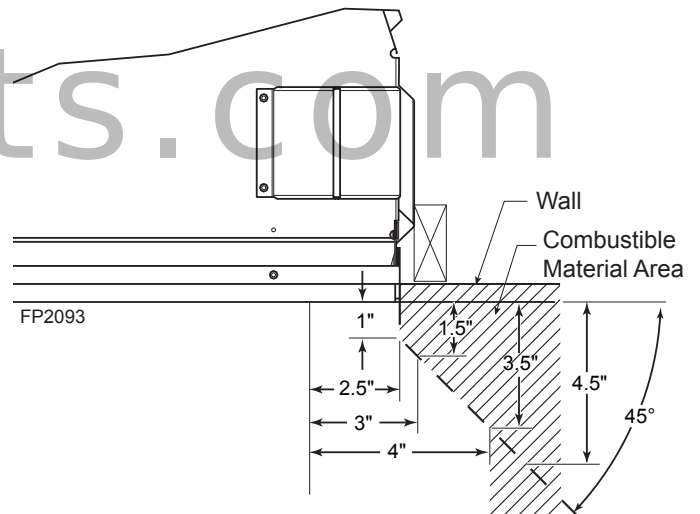
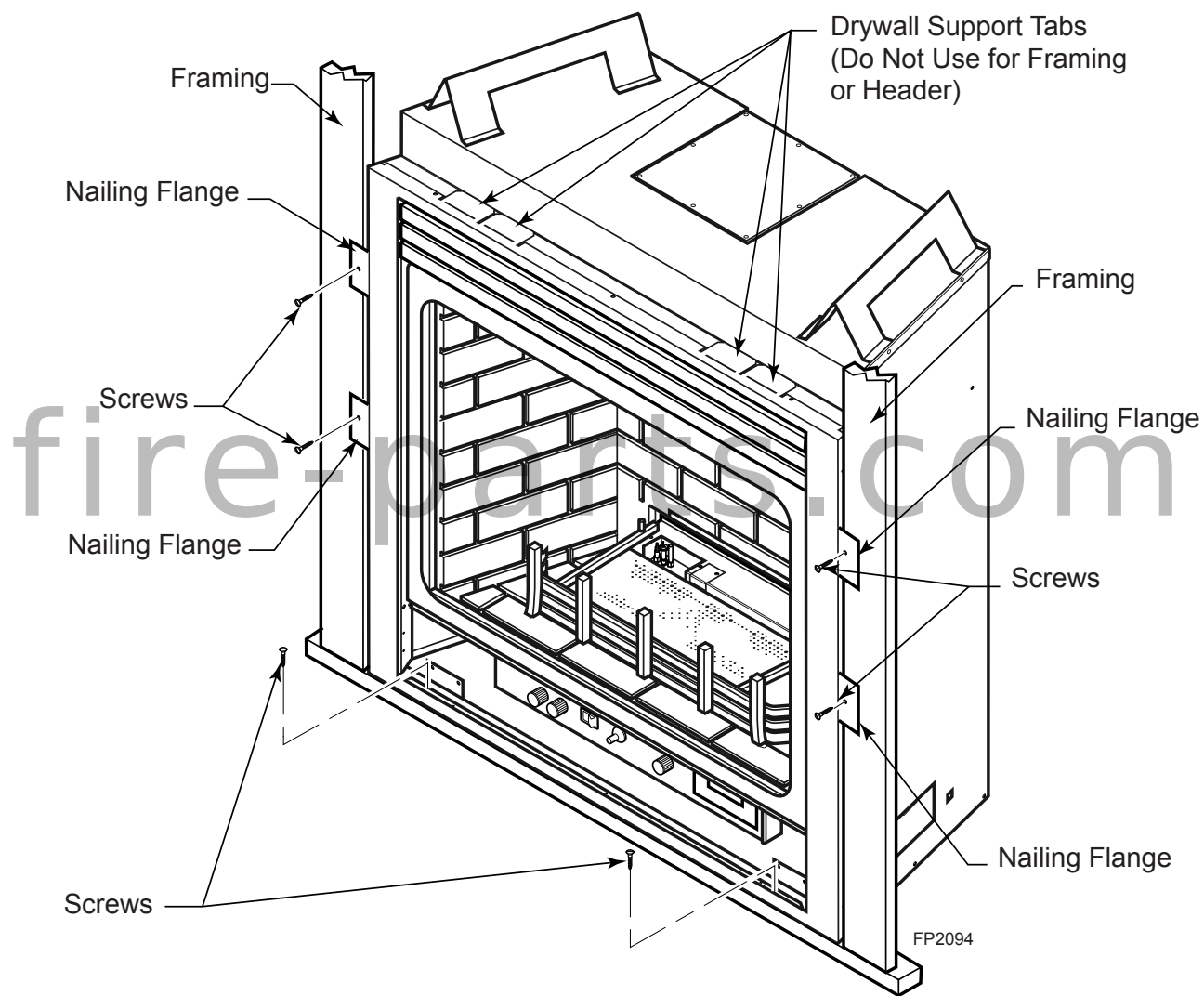

Figure 5a - Mantel Clearances

MANTEL CLEARANCES

NOTE: The combustible area above the facing must not protrude more than 3/4" from the facing. If it does, it is considered a mantel and must meet the mantel requirements listed in this manual.

The fireplace must be secured to the floor and/or to framing studs as shown in Figure 6. Use two (2) wood screws or masonry/ concrete screws to secure fireplace to the floor. Use four (4) screws to attach fireplace to framing. The side nailing flanges are 1/2" or 5/8" to accommodate different wall thickness.



**Figure 6 -
Securing Fireplace to Floor and Framing Studs**

FINISHING MATERIAL

NOTE: Any remote wiring (i.e. remote control, wall switch, and optional fan) must be done prior to final finishing to avoid costly reconstruction.

WARNING Never obstruct or modify the air inlet or outlet grills (louvers). This may create a fire hazard.

Only noncombustible materials (i.e. brick, tile, slate, steel, or other materials with a UL fire rating of Zero) may be used to cover the black surface of the appliance. A 300°F minimum adhesive may be used to attach facing materials to the black surface. If joints between the finished wall and the fireplace surround are sealed, a 300°F minimum sealant material (General Electric RTV103 or equivalent) must be used.

VENT INSTALLATION

WARNING Read all instructions completely and thoroughly before attempting installation. Failure to do so could result in serious injury, property damage or loss of life. Operation of improperly installed and maintained venting system could result in serious injury, property damage or loss of life.

NOTICE Failure to follow these instructions will void the warranty.

INSTALLATION PRECAUTIONS

Consult local building codes before beginning the installation. The installer must make sure to select the proper vent system for installation. Before installing vent kit, the installer must read this fireplace manual and vent kit instructions.

Only a qualified installer/service person should install venting system. The installer must follow these safety rules:

- Wear gloves and safety glasses for protection.
- Use extreme caution when using ladders or when on rooftops.
- Be aware of electrical wiring locations in walls and ceilings.

The following actions will void the warranty on your venting system:

- Installation of any damaged venting component.
- Unauthorized modification of the venting system.
- Installation of any component part not manufactured or approved by MHSC.
- Installation other than permitted by these instructions.

WARNING

This fireplace must be vented to the outside. The venting system must **NEVER** be attached to a chimney serving a separate solid fuel burning appliance. Each gas appliance must use a separate vent system. Do not use common vent systems.

WARNING

Horizontal sections of this vent system require a minimum of 3" clearances to combustibles at the top of the flue and 1" clearance at the sides and bottom *until the flue penetrates the outside wall*. A minimum 1" clearance all around the flue is acceptable at this point of penetration. If vertical rise is 7½ feet or higher when top venting, the clearance to combustibles is 1" on all sides of the horizontal run.

Vertical sections of this vent system require a minimum of 1" clearance to combustibles on all sides of the pipe.

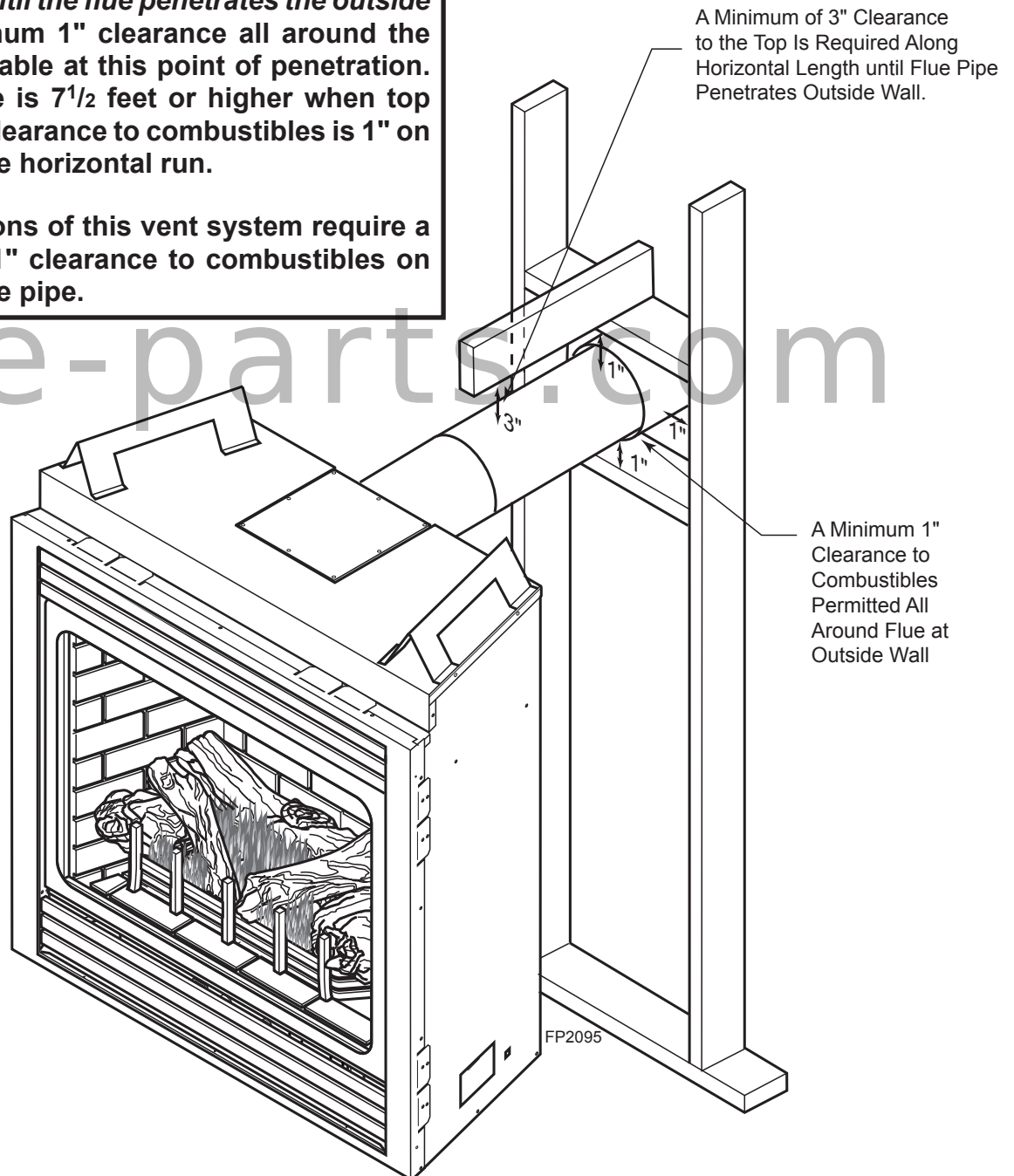

Figure 7 - Combustible Clearances for Vent Pipe

OPTIONAL TOP VENT APPLICATION

The appliance is shipped as a rear vent unit. If the installation layout requires the unit to be a top vent configuration the appliance can be converted by following the steps below.

When removing and refitting the plates and adapter be sure the associated gaskets are undamaged and refitted as required.

1. Remove the eight (8) screws securing the flue pipe adapter to the fireplace body. *Figure 8*
2. Set the flue pipe adapter aside, complete with the gasket. Do not damage the gaskets as the adapter and gasket must be refitted.
3. Remove the eight (8) screws securing the flue pipe cover to the top of the intake box and remove the cover and gasket. *Figure 8*
4. Remove the six (6) screws securing the flue pipe to the back of the intake box and remove the pipe and gasket. *Figure 9*
5. Replace flue pipe to top of firebox. Ensure the gasket is in place and undamaged. Secure with six (6) screws. *Figure 10*
6. Place the flue pipe cover and gasket removed in Step 3 over the flue opening in back of the intake box.
7. Refit the flue pipe adapter and gasket to the top of fireplace. Secure the adapter with eight (8) screws removed in step 1.

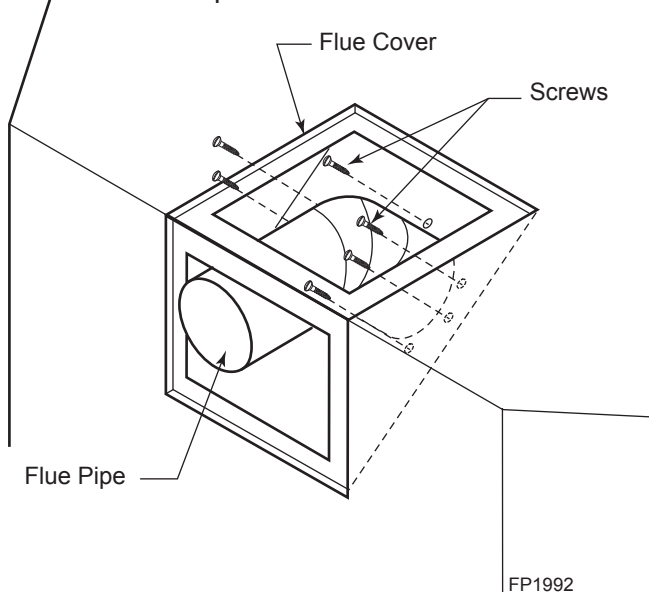

Figure 9 - Removing Flue Pipe

WARNING After conversion to top vent configuration the 4" (100mm) flue pipe should be concentric within the 6⁵/₈" (175mm) outer collar (within 1/4").

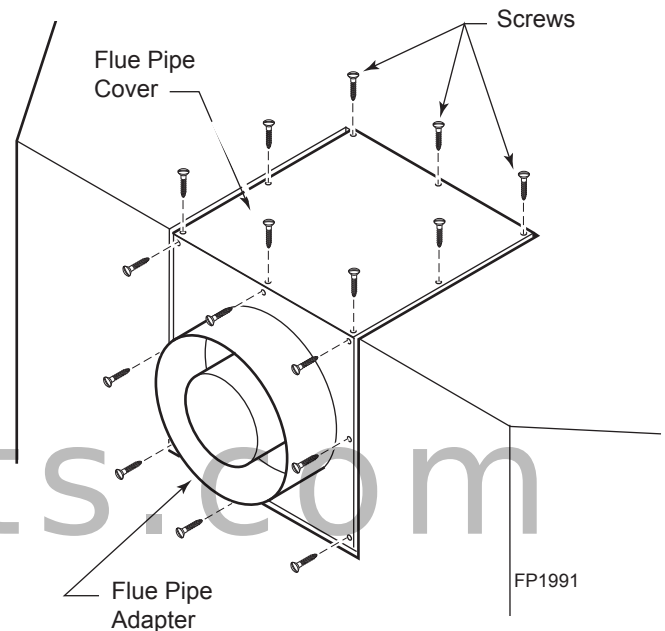

Figure 8 - Removing sixteen (16) Screws from Flue Pipe Adapter and Flue Pipe Cover

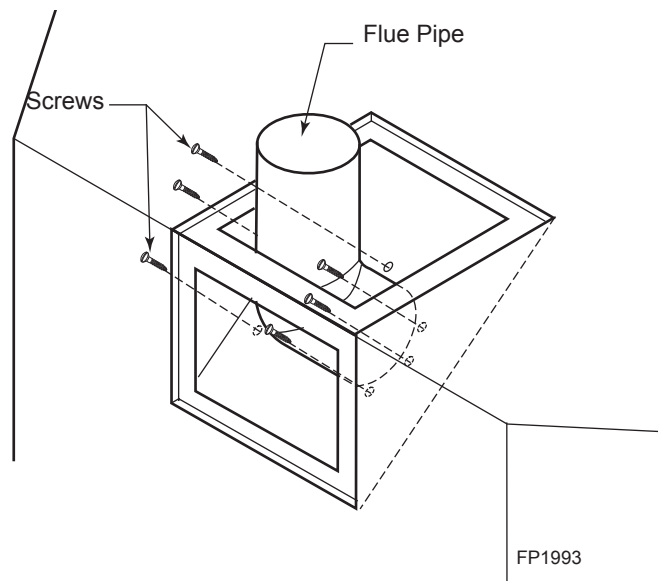

Figure 10 - Attaching Flue Pipe to Top Vent Configurations

INSTALLATION PLANNING

There are two basic types of direct-vent installation:

- Horizontal Termination
- Vertical Termination

It is important to select the proper length of vent pipe for the type of termination you choose. It is also important to note the wall thickness.

FOR HORIZONTAL TERMINATION

Select the amount of vertical rise desired. All horizontal run of venting must have 1/4" rise for every 12" of run towards the termination below 7¹/₂ ft. of vertical rise. With 7¹/₂ ft. or more vertical rise, the horizontal run may run level. NEVER run vent piping downward.

You may use up to three 90° elbows in this vent configuration. Refer to Horizontal Termination Configurations on pages 20 and 21.

FOR VERTICAL TERMINATION

Measure the distance from the fireplace floor to the ceiling. Add the ceiling thickness, the vertical rise in an attic or second story, and allow for sufficient vent height above the roof line.

NOTE: *You may use two 45° elbows in place of a 90° elbow. You must follow rise to run ratios when using 45° elbows. The appliance is approved for use with three 90° elbows maximum or a combination of 90° and 45° elbows up to a maximum of 270°.*

For two-story applications, firestops are required at each floor level. If an offset is needed in the attic, additional pipe and elbows will be required.

You may use a chase with a vent termination with exposed pipe on the exterior of the house. See Installing Vent System in a Chase below. If pipe is enclosed in chase, it is not exposed.

It is very important that the venting system maintain its balance between the combustion air intake and the flue gas exhaust. Certain limitations apply to vent configurations and must be strictly followed.

INSTALLING A VENT SYSTEM IN AN OUTSIDE CHASE

A chase is a vertical boxlike structure built to enclose venting that runs along the outside of a building. A chase is required for such venting.

WARNING

Never run the vent pipe downward. This may cause excessive temperatures which could cause a fire.

NOTICE

Treatment of firestops and construction of the chase may vary from building type to building type. These instructions are not substitutes for the requirements of local building codes. You must follow all local building codes.

NOTICE

When installing in a chase, you should insulate the chase as you would the outside walls of your home. This is especially important in cold climates. Insulation should be considered a combustible material. Maintain proper clearances to all combustible materials.

FOR HORIZONTAL TERMINATION

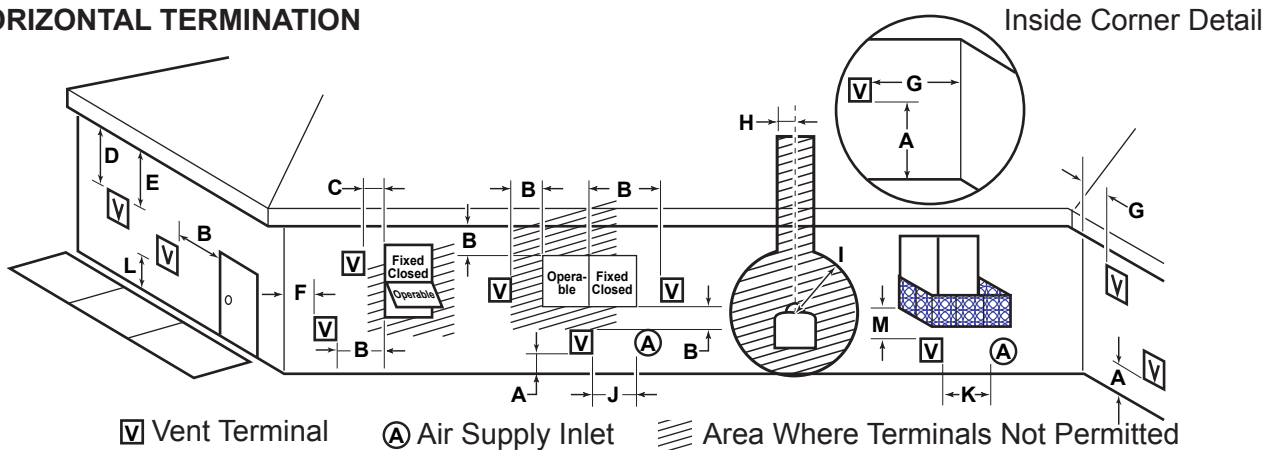

Figure 11 - Horizontal Vent Termination Location

MINIMUM DISTANCES

- A = Clearance above the grade, a veranda, porch, deck, or balcony [*12" (305mm) minimum].
 - B = Clearance to window or door that may be opened [*12" (305mm) minimum].
 - C = Clearance to permanently closed window [*minimum 12" (305mm) recommended to prevent condensation on window]
 - D = Vertical clearance to ventilated soffit located above the terminal within a horizontal distance of two (2) feet (610mm) from the centerline of the terminal [18" (457mm) minimum].
 - E = Clearance to unventilated soffits [12" (305mm) minimum]. Clearance to vinyl soffit [30" (762mm)].
 - F = Clearance to an outside corner. *Figure 12*
 - G = Clearance to an inside corner. *Figure 12*
 - H = *Not to be installed above a gas meter/regulator assembly within three (3) feet (914mm) horizontally from the centerline of the regulator.
 - I = Clearance to service regulator vent outlet [*3' (914mm) minimum].
 - J = Clearance to non-mechanical air supply inlet to building or the combustion air inlet to any other appliance [*12" (305mm) minimum].
 - K = Clearance to a mechanical air supply inlet [*6' (1829mm) minimum].
 - L = Clearance above a paved sidewalk or paved driveway located on public property [*7' (2133mm) minimum].
 - M = Clearance under veranda, porch, deck or balcony, refer to *Figure 12*.
- * As specified in CSA B149 Installation Codes. Note: Local codes or regulations may require different clearances.
- ** A vent must not terminate directly above a sidewalk or paved driveway, which is located between two single-family dwellings and serves both dwellings.
- *** Only permitted if veranda, porch, deck, or balcony is fully open on a minimum of two sides beneath the floor.

WARNING

Always maintain minimum clearances around vent systems. The minimum clearances to combustibles for horizontal vent pipe are 3" at the top and 1" at the sides and bottom of the vent system until the pipe penetrates the nearest vertical wall (1" required). A 1" minimum clearance all around the pipe must be maintained at outside wall and on vertical runs. Do not pack the open air spaces with insulation or other materials. This could cause high temperatures and may present a fire hazard.

***Unless the vertical run is 7½ feet or higher (top vent units only), the clearances for the horizontal run is 1" at the top.**

TERMINATION CLEARANCES FOR BUILDINGS WITH COMBUSTIBLE AND NONCOMBUSTIBLE EXTERIORS

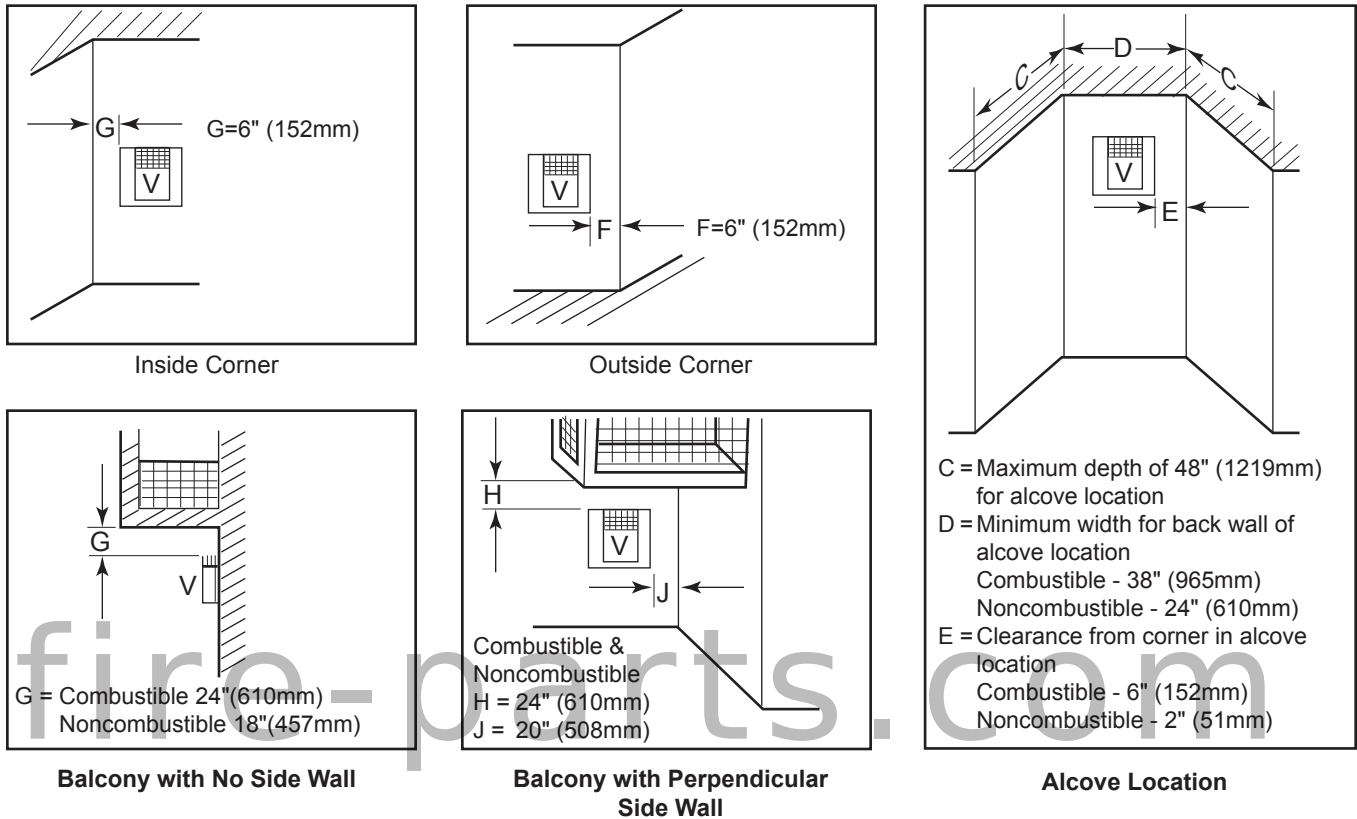

Figure 12 - Allowable Venting Chart

HOW TO USE THE VENT GRAPH

The Vent Graph should be read in conjunction with the following vent installation instructions to determine the relationship between the vertical and horizontal dimensions of the vent system.

1. Determine the height of the center of the horizontal vent pipe exiting through the outer wall. Using this dimension on the Sidewall Vent Graph below, locate the point intersecting with the slanted graph line.
2. From the point of this intersection, draw a vertical line to the bottom of the graph.
3. Select the indicated dimension, and position the fireplace in accordance with same.

Example: If the vertical dimension from the floor of the fireplace is 11' (3.4m) the horizontal run to the face of the outer wall must not exceed 14' (4.3m).

Example: If the vertical dimension from the floor of the unit is 7' (2.14m), the horizontal run to the face of the outer wall must not exceed 8½' (2.6m).

Sidewall Vent Graph showing the relationship between vertical and horizontal dimensions for a Direct Vent flue system.

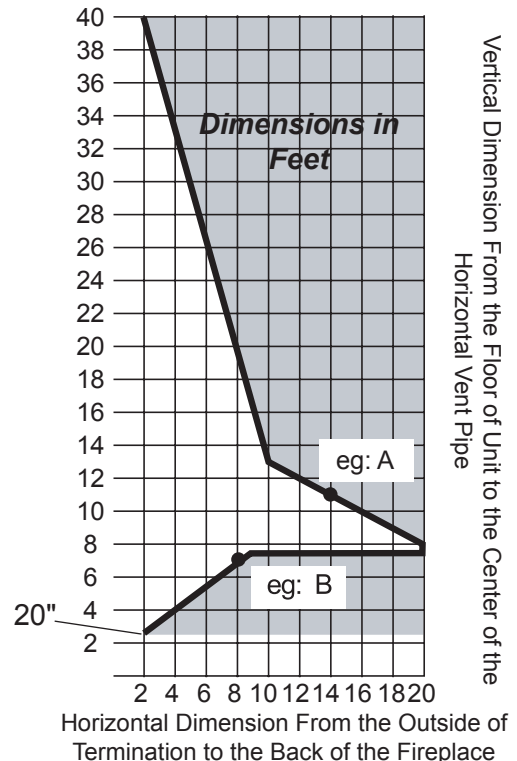

Figure 13 - Rear Wall Venting Graph

REAR (THROUGH THE WALL) APPLICATIONS

When installed as a rear vent unit this appliance may be vented directly to a termination located on the rear wall behind the appliance

- The maximum horizontal distance between the rear of the appliance and the outside of termination is 20" (508 m). *Figure 14*
- Only one 45° elbow is allowed in these installations.

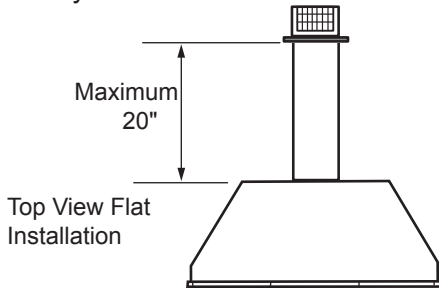

Figure 14 - Rear Vent Application, Maximum Horizontal Distance

Sealant is not required to assemble BDV/DVB fireplace venting. Do not use silicone sealant at the flue exhaust connections.

1. Find the pipe section's direction label. The label arrow shall be pointed away from the firebox and toward the termination. Firmly insert the initial rigid section/elbow into the firebox outer collar. Simpson "GS" and Selkirk "DT" outer walls are hemmed and will snap into the collar's tabs. Attach Simpson's DirectVent Pro by fully inserting into the collar and securing with self tapping screws. The screws shall only penetrate the flue outer wall.

Refer to vent manufacturer's installation instructions to properly assemble flue.

2. Locate and cut the vent opening in the wall. For combustible walls first frame in opening.

Combustible Interior Walls: Cut a 11½"H x 9½" W hole through the interior wall.

Combustible Exterior Walls: Cut a 9½"H x 9½"W square hole through the exterior wall frame. *Figure 16*

Noncombustible Walls: Hole opening should be 7½" (190mm) in diameter.

3. The center of the hole should line up with the center line of the horizontal rigid vent pipe end. Pipe shall always run level or uphill on horizontal runs. Never run pipe down hill. *Figure 16*

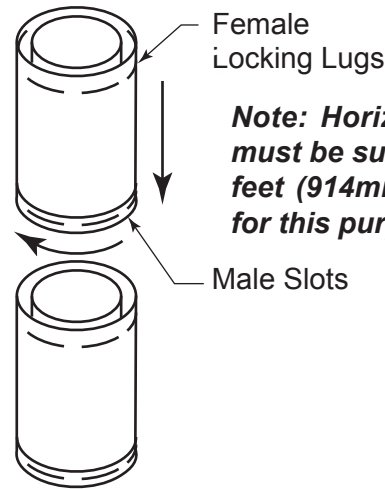

Figure 15 - Rigid Vent Pipe Connections

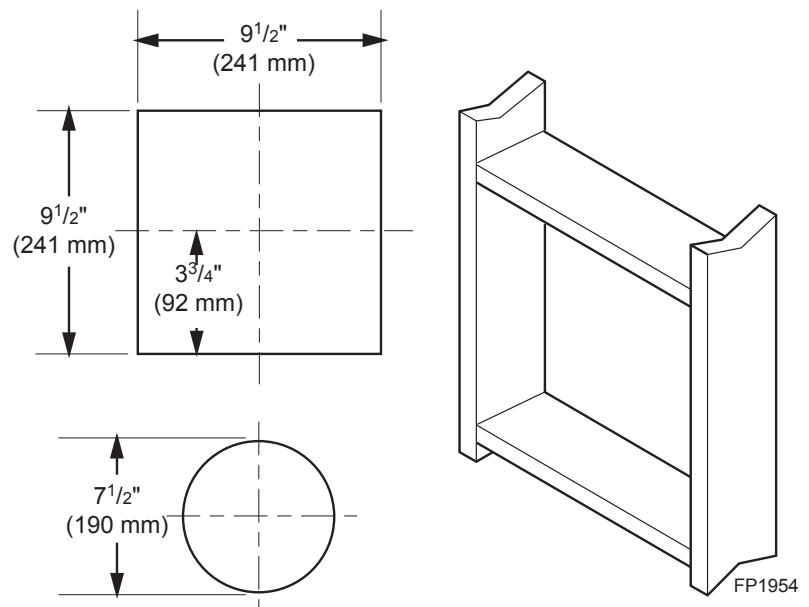

Figure 16 - Exterior Wall Framing Dimensions

REAR WALL VENT INSTALLATION (continued)

4. Apply a bead of non-hardening mastic around the outside edge of vent cap. Position the vent cap in the center of hole on the exterior wall with the word "UP" on the vent cap facing up. Insure proper clearance of 1" to combustibles is maintained to the flue. Attach the vent cap with four wood screws supplied. *Figure 17*

WARNING
Do not recess vent termination into any wall. This will cause a fire hazard.

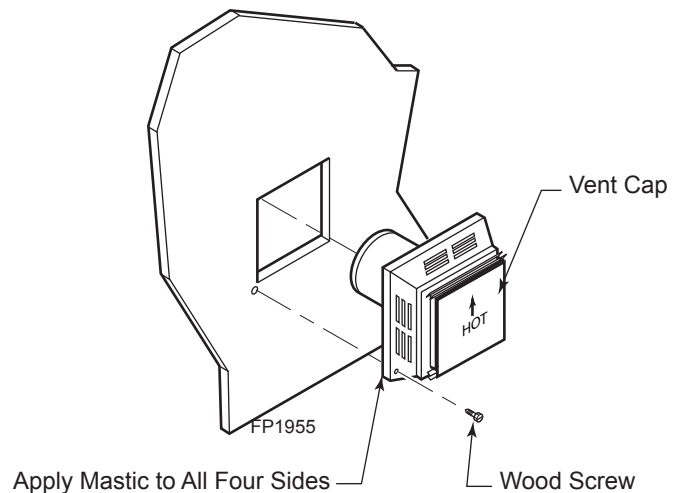

Figure 17 - Installing Horizontal Termination

NOTE: Replace the wood screws with appropriate fasteners for stucco, brick, concrete, or other types of siding.

A vinyl siding standoff (part #950) must be used with the Simpson/Selkirk Horizontal Termination (part #985) on vinyl, stucco or wood-clad exterior walls. Apply non-hardening mastic around outside edge of the standoff instead of the vent cap assembly. *Figure 18*

5. Slide the firestop over the vent pipe before connecting the horizontal run to the vent cap. *Figure 19*
6. The termination should overlap the flue a minimum of 1¹/₄" Apply silicone to the outer pipe/termination connection. Fasten termination with screws provided.
7. Slide the firestop against the interior wall surface and attach with screws. *Figure 19*

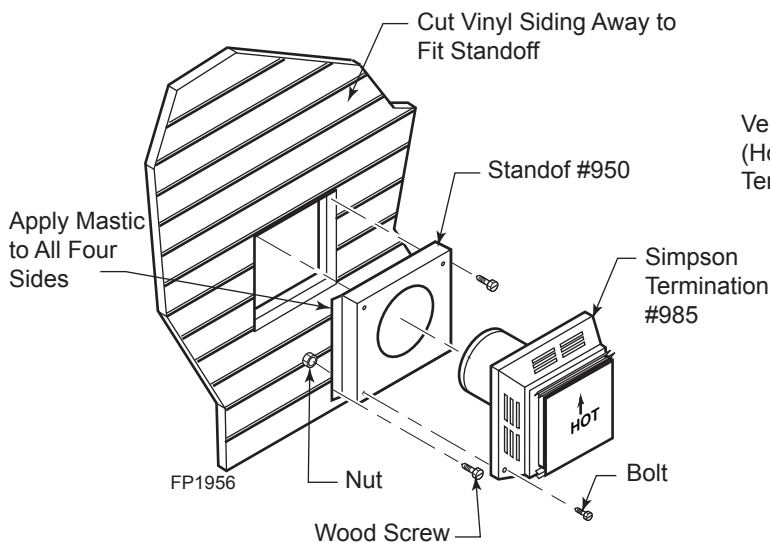

Figure 18 - Installing Simpson/Selkirk Vinyl Siding Standoff and Termination

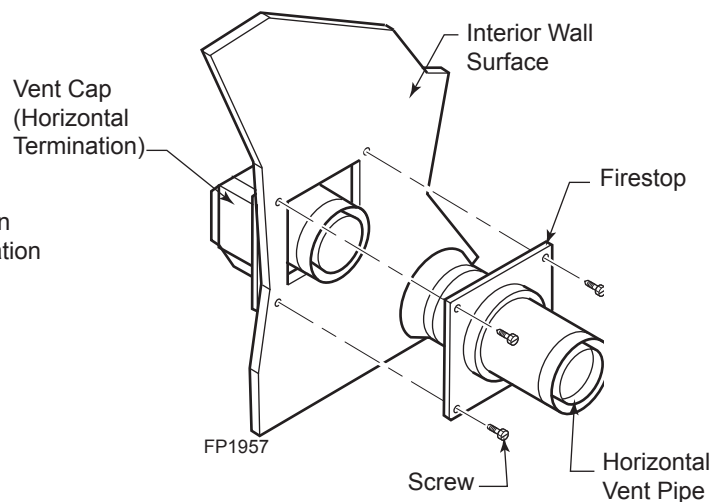

Figure 19 - Installing Firestop on Horizontal Vent Pipe

HORIZONTAL TERMINATION CONFIGURATION

(Continued)

- If a 90° elbow is used in the horizontal vent run (level height maintained) the horizontal vent length is reduced by 36". *Figures 21 and 22, page 20.* This does not apply if the 90° elbows are used to increase or redirect a vertical rise. *Figure 24*

Example: According to the vent graph (page 20) the maximum horizontal vent length in a system with a 7.5' vertical rise is 20' (6m) and if a 90° elbow is required in the horizontal vent it must be reduced to 17' (5.2 m).

In Figures 23 and 24, Dimension A plus B must not be greater than 17' (5.2m).

- The maximum number of 45° elbows permitted per side wall installation is two (2). These elbows can be installed in either the vertical or horizontal run.
- For each 45° elbow installed in the horizontal run, the length of the horizontal run **MUST** be reduced by 18" (45cm). This does not apply if the 45° elbows are installed on the vertical part of the vent system.
- The maximum number of elbow degrees in a system is 270°. *Figure 25*

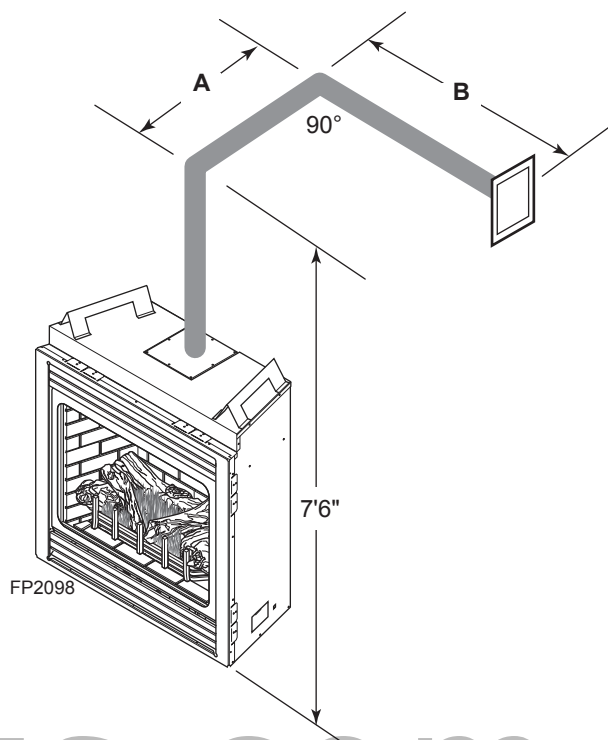

Figure 23 - Horizontal Run Reduction

Example:

Elbow 1 =	90°
Elbow 2 =	45°
Elbow 3 =	45°
Elbow 4 =	90°
<hr/>	
Total Angular Variation =	270°

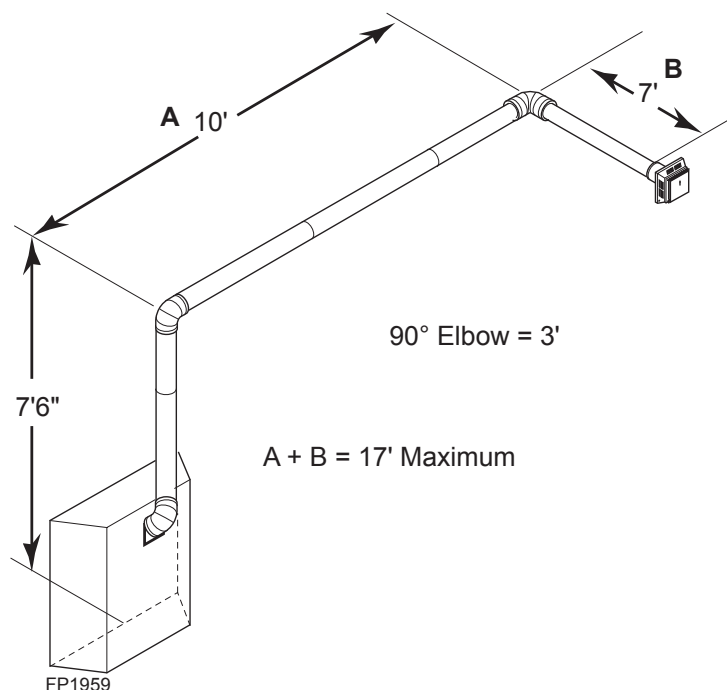

Figure 24 - Maximum Vent Run with Elbows

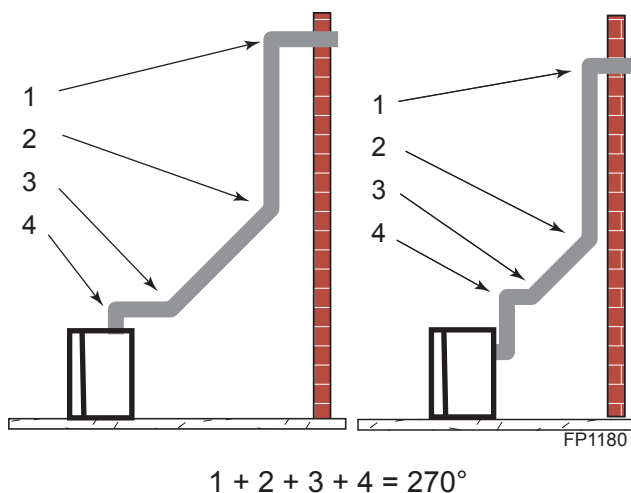

Figure 25 - Maximum Elbow Usage

BELOW GRADE INSTALLATIONS

When it is not possible to meet the required vent terminal clearances of 12" above grade level, a snorkel kit is recommended. It allows installation depth down to 7" (178 mm) below grade level. The 7" (178 mm) is measured from the center of the horizontal vent pipe as it penetrates through the wall.

Ensure that sidewall venting clearances are observed. If venting system is installed below ground, we recommend a window well with adequate and proper drainage to be installed around the termination area.

If installing a snorkel, a minimum 24" vertical rise is necessary. The maximum horizontal run with the 24" vertical pipe is 36". This measurement is taken from the collar of the fireplace (or transition elbow) to the face of the exterior wall. See the Sidewall Venting Graph for extended horizontal run if the vertical exceeds 24".

1. Establish vent hole through the wall. *Figure 16, page 18*
2. Remove soil to a depth of approximately 16" below base of snorkel. Install drain pipe. Install window well (not supplied). Refill hole with 12" of coarse gravel leaving a clearance of approximately 4" below snorkel. *See Figure 26.*
3. Install vent system.
4. Ensure a watertight seal is made around the vent pipe coming through the wall.
5. Apply high temperature sealant caulking (supplied) around the 4" and 7" snorkel collars.
6. Slide the snorkel into the vent pipes and secure to the wall.
7. Level the soil so as to maintain a 4" clearance below snorkel. *Figure 26*

WARNING

- Do not back fill around snorkel.
- A clearance of at least 4" must be maintained between the snorkel and the soil.

If the foundation is recessed, use recess brackets (not supplied) for securing lower portion of the snorkel. Fasten brackets to wall first, then secure to snorkel with self drilling #8 x 1/2 sheet metal screws. It will be necessary to extend vent pipes out as far as the protruding wall face. *Figure 27*

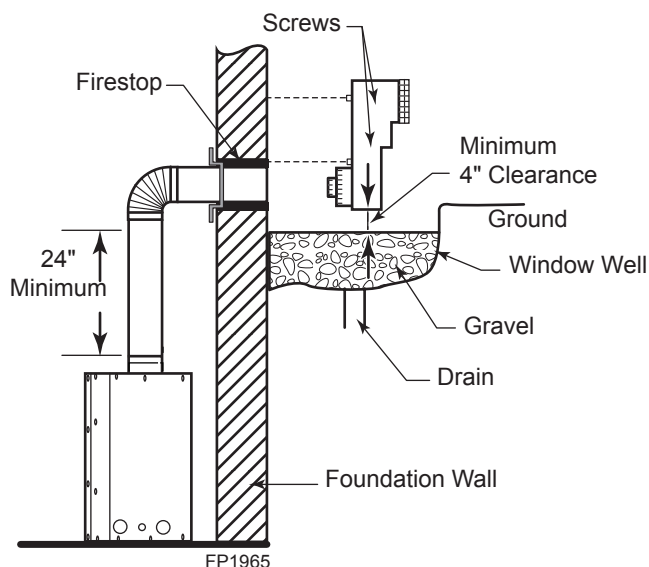

Figure 26 - Below Grade Installation

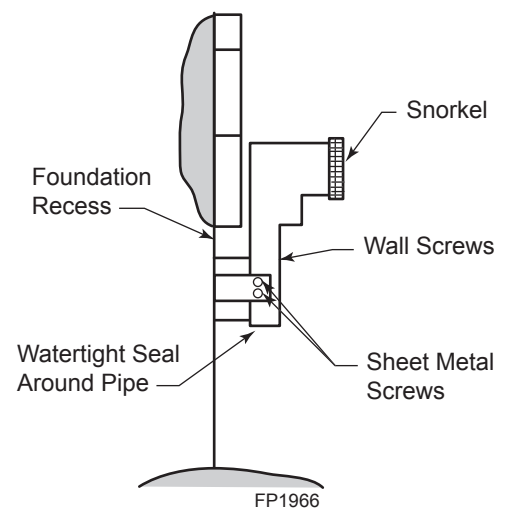

Figure 27 - Snorkel Installation, Recessed Foundation

VERTICAL (THROUGH-THE-ROOF) APPLICATIONS

This Gas Fireplace has been approved for,

- Vertical installations up to 40' (12 m) in height. Up to a 10' (3 m) horizontal vent run can be installed within the vent system using a maximum of two 90° elbows. *Figure 28*

NOTE: Horizontal sections of this vent system require a minimum of 3" clearances to combustibles at the top of the flue unless the vertical run is 7½ feet or higher the clearances for the horizontal run is 1" at the top, and 1" clearance at the sides and bottom until the flue penetrates the outside wall. A minimum 1" clearance all around the flue is acceptable at this point of penetration.

Vertical sections of this vent system require a minimum of 1" clearance to combustibles on all sides of the pipe.

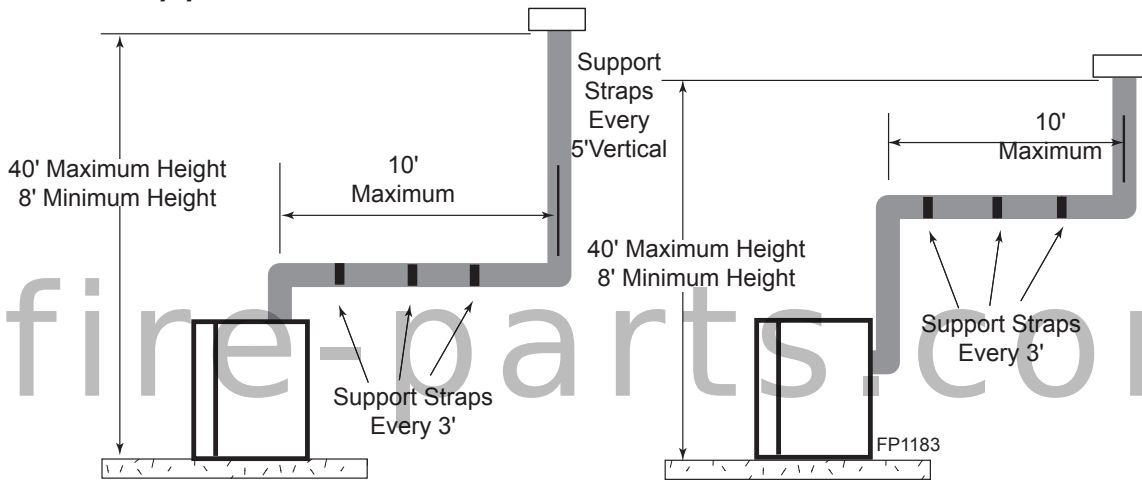

Figure 28 - Support Straps for Horizontal Runs

- Up to two 45° elbows may be used within the horizontal run. For each 45° elbow used on the horizontal plane, the maximum horizontal length must be reduced by 18" (450 mm).

Example: Maximum horizontal length

- No elbows = 10' (3 m)
- 1x45° elbows = 8.5' (2.6 m)
- 2x45° elbows = 7' (2.1 m)

- A minimum of an 8' (2.5 m) vertical rise is required.
- Two sets of 45°elbows offsets may be used within the vertical sections. From 0 to a maximum of 8' (2.5 m) of vent pipe can be used between elbows. *Figure 29*
- The maximum angular variation allowed in the system is 270°. *Figure 29*

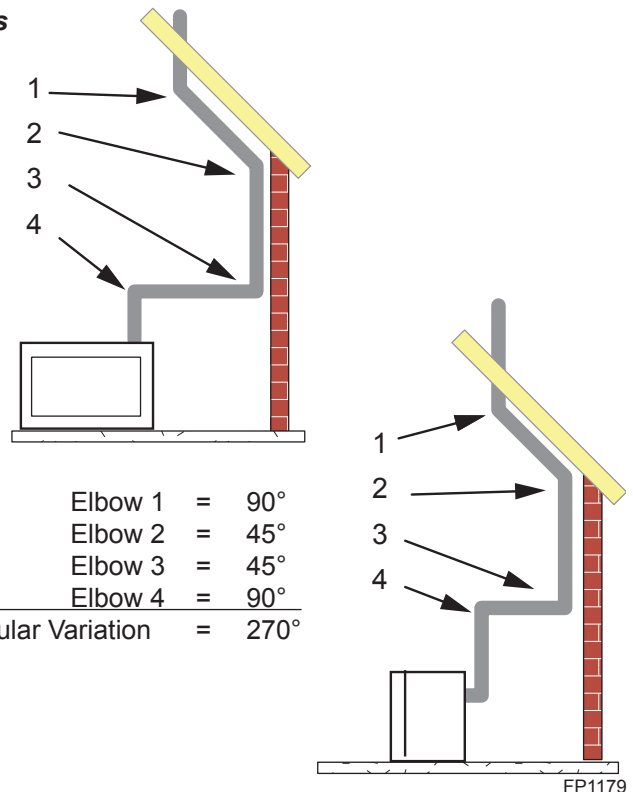

Example:

Elbow 1	=	90°
Elbow 2	=	45°
Elbow 3	=	45°
Elbow 4	=	90°
<hr/>		
Total Angular Variation	=	270°

Figure 29 - Maximum Elbow Usage

INSTALLATION FOR VERTICAL TERMINATION

1. Determine the route your vertical venting will take. If ceiling joist, roof rafters or other framing will obstruct the venting system, consider an offset. Refer to *Figure 30* to avoid cutting load bearing members.

For optimal flame appearance, a restrictor disk is necessary on straight vertical runs of 20' or more.

- Runs may not incorporate elbows.
- The disk is part number 45D0551 and is included in installation manual packet.
- Drop the disk into a 4" inner collar before installing the first section of flue or install at the last section before installing the termination.
- An additional disk may be installed on runs of 35' or more. Rotate disks perpendicular to each other.

NOTE: Pay special attention to these installation instructions for required clearances (air space) to combustibles when passing through ceilings, walls, roofs, enclosures, attic rafters, etc. Do not pack air spaces with insulation. Also note maximum vertical rise of the venting system and any maximum horizontal offset limitations. Offsets must fall within the parameters shown in *Figure 13*, page 20.

2. Set fireplace in desired location. Drop a line plumb down from the ceiling to the position of the flue exit. Mark the center point where the vent will penetrate the ceiling. Drill a small locating hole at this point.

Drop a plumb line from the inside of the roof to the ceiling locating hole in the ceiling. Mark the center point where the vent will penetrate the roof. Drill a small locating hole at this point.

FLAT CEILING INSTALLATION

1. Cut a 9 $\frac{1}{2}$ " (241 mm) square hole in the ceiling using the locating hole as a center point. The opening should be framed to 9 $\frac{1}{2}$ " x 9 $\frac{1}{2}$ " (241 mm x 241 mm) inside dimensions as shown in *Figure 32* using framing lumber the same size as the ceiling joist. If the area above the ceiling is an insulated ceiling or a room, nail firestop from the top side. This prevents loose insulation from falling into the required clearance space. *Figure 31*. Otherwise, install firestop below the framed hole. *Figure 32*
2. Assemble the desired lengths of pipe and elbows necessary to reach from the burner system flue up through the firestop. Be sure pipe and elbow connections are fully twist-locked. *Figure 15*, page 18

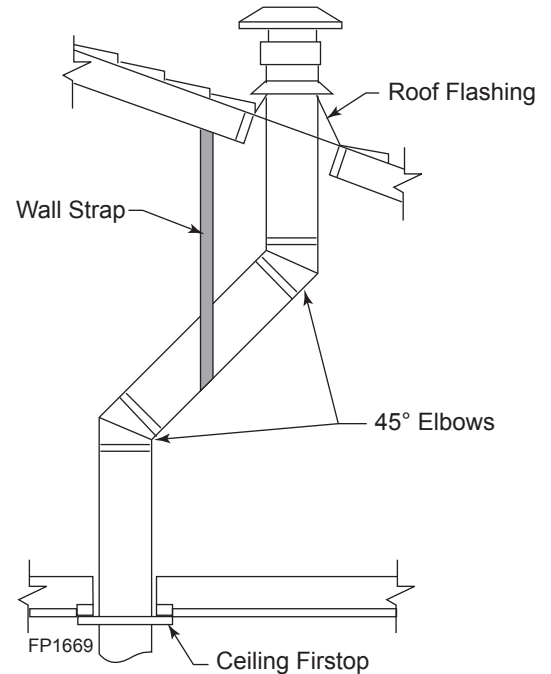

Figure 30 - Offset with Wall Strap and 45° Elbows

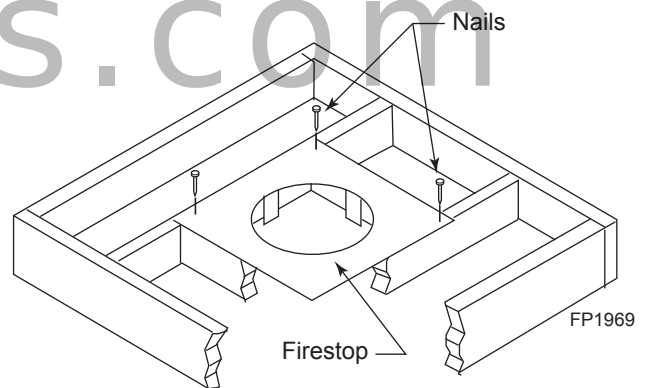

Figure 31 - If Area Above is a Room, Install Firestop above Framed Hole as Shown

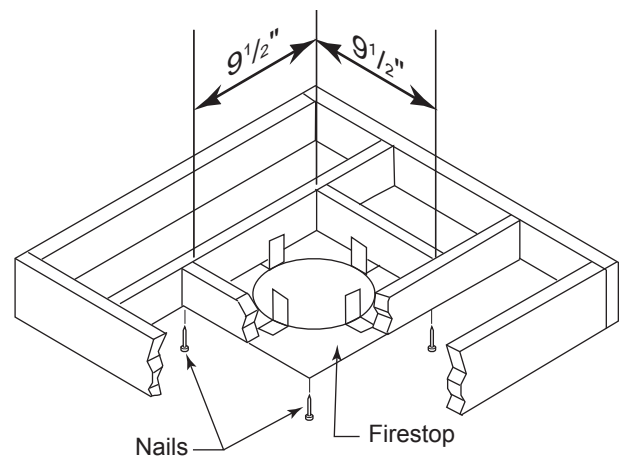

Figure 32 - If Area Above is Not a Room, Install Firestop above Framed Hole as Shown

3. Cut a hole in the roof using the locating hole as a center point. (Cover any exposed open vent pipes before cutting hole in roof). The 9¹/₂"x9¹/₂" (241 mm x 241 mm) hole must be measured on the horizontal. Actual length may be larger depending on the pitch of the roof. There must be a 1" minimum clearance from the vent pipe to combustible materials. (Insulation should be considered a combustible material).
4. Connect a section of pipe and extend up through the hole.

NOTE: If an offset is needed to avoid obstructions, you must support the vent pipe every three (3) feet. Use wall straps for this purpose. Refer to Figure 28, page 23. Whenever possible, use 45° elbows instead of 90° elbows. The 45° elbow offers less restriction to the flow of the flue gases and intake air.

5. Place the flashing over the pipe section(s) extending through the roof. Secure the base of the flashing to the roof and framing with roofing nails. Be sure roofing material overlaps the top edge of the flashing. There must be a 1" clearance from the vent pipe to combustible materials.
6. Continue to add pipe sections until the height of the vent cap meets the minimum building code requirements.

NOTE: You must increase vent height for steep roof pitches. Nearby trees, adjoining roof lines, steep pitched roofs, and other similar factors may cause poor draft or down-drafting in high winds. Increasing the vent height may solve this problem.

NOTE: If the vent pipe passes through any occupied areas above the first floor, including storage spaces and closets, you must enclose pipe. You may frame and sheetrock the enclosure with standard construction material. Make sure to meet the minimum allowable clearances to combustibles. Do not fill any of the required clearance spaces with insulation.

CATHEDRAL CEILING INSTALLATION

1. Remove shingles or other roof covering as necessary to cut the rectangular hole for the support box. Mark the outline of the cathedral ceiling support box on the roof sheathing using the locating hole as a center point.
2. Cut the hole 1/8" larger than the support box outline. *Figure 32*
3. Lower the support box through the hole in the roof until the bottom of the box extends at least 2" below the ceiling. Align the support box vertically and horizontally using a level. Temporarily tack the support box in place through the inside walls and into the roof sheathing.
4. Using tin snips, cut the support box from the top corners down to the roof line and fold the resulting flaps over the roof sheathing. *Figure 33*. Apply a bead of non-hardening, mastic around the top edges of the support box to make a seal between the box and the roof. Nail in place with roofing nails. Remove any combustible material that might be inside the support box.
5. Complete the cathedral ceiling installation by following the same procedures outlines in steps 2 through 6 for Flat Ceiling Installation.

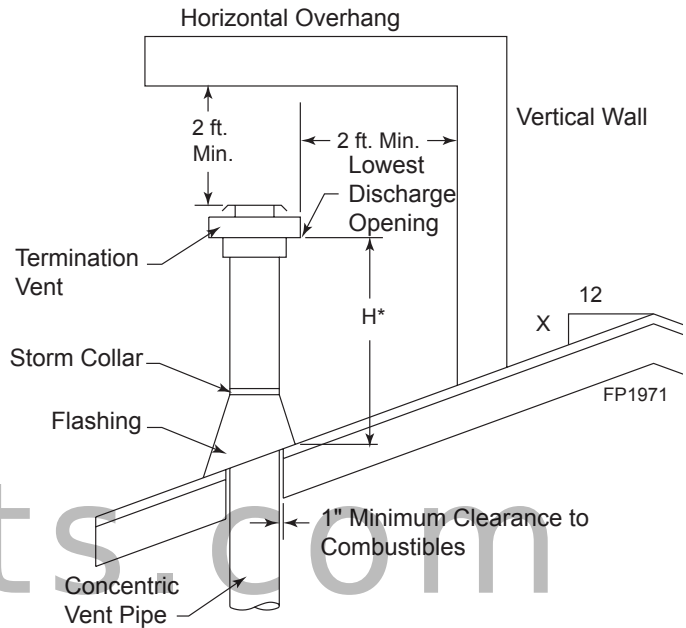

Figure 33 - Minimum Chimney Clearance

Roof Pitch	H (feet)
Flat to 6/12	1.0
Over 6/12 to 7/12	1.25
Over 7/12 to 8/12	1.5
Over 8/12 to 9/12	2.0
Over 9/12 to 10/12	2.5
Over 10/12 to 11/12	3.25
Over 11/12 to 12/12	4.0

*H - Minimum height from roof to lowest discharge opening of vent

1. Flexible UL1777 listed venting may be used in any venting application where rigid direct vent components can be used. **All restrictions, clearances and allowances that pertain to the rigid piping apply to the flexible venting.** Flex kits may not be modified. Flex kits may be added to the end of a vent run made of rigid vent sections using pipe manufacturer's approved flex to pipe adapters. This may occur only if doing so does not violate any of the venting length, height, routing, horizontal to vertical ratio requirements or clearance considerations detailed in this manual.

2. The flex adapter starter kit (DVFA/8) is used to attach flex venting to the appliance starting collar. It includes 4" inner and 7" outer adapter rings. *Figure 34*

- The inner and outer adapter rings are required to start all flex runs.
- Never install damaged or torn flexible venting.
- Over tightening clamps may rip, tear, or otherwise damage flexible venting.
- The adapter kit does not include individual pipe sections which may be purchased separately. (UL1777 listed type venting only.)

3. Start the flexible vent as follows:

A. Installing the inner flex adapter and pipe. *Figure 34*

1. Insert the long side of the 4" inner ring into exhaust pipe, gently tap to seat into place, and secure with screws.
2. Slide the small gear clamp over the inner flexible vent pipe, and push out of the way.
3. Pull and extend the inner flexible vent.
4. Slide the inner vent onto the adapter collar, for a minimum 1³/₄" overlap.
5. Locate the clamp at approximately 3/4" from the flex end and tighten.
6. Secure the clamped inner section with three self-tapping screws, drilled equidistant, just above the clamp perimeter.

B. Installing the outer flex pipe. *Figure 34*

1. Firmly insert the outer adapter ring into the outer appliance starting collar and secure with screws.
2. Slide the large gear clamp over the outer flexible vent pipe, and push out of the way.
3. Pull and extend the outer flexible vent.
4. Slide the outer vent onto the appliance collar outer adapter for a minimum 1³/₄" overlap.
5. Locate the clamp at approximately 3/4" from the flex end and tighten.
6. Secure the clamped outer section with three self-tapping screws, drilled equidistant, just above the clamp perimeter.

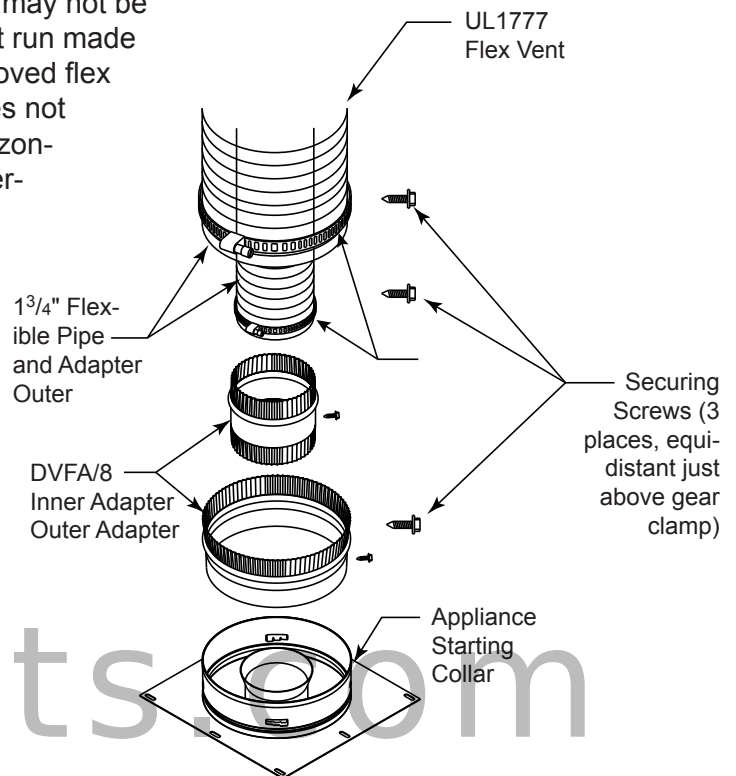

Figure 34 - Typical Appliance Connection

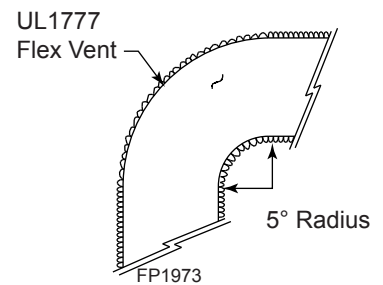

Figure 35 - Minimum Radius for Flex Vent Section

NOTE

Flex vent pipe spacers: Refer to manufacturer's specifications for correct positioning of the spacer springs to maintain proper distance between inside and outside pipe.

C. Routing UL1777 flex pipe.

1. Always maintain the required clearance when routing the flex vent assembly.
 2. Install firestop spacers (*Figure 36*) when penetrating ceiling, attic spaces, or walls.
 3. Do not allow the flexible vent to bend in radius tighter than 5" (127 mm). *Figure 35*
 4. Horizontal runs of flexible vent shall be supported at maximum 2 foot intervals; vertical runs, five feet intervals. Metal strapping, properly secured, is an acceptable means to support the flexible vent.
5. Flexible vent spacers are to be installed at intervals prescribed by the flexible vent manufacturer; and in such a way as to maintain concentric inner and outer vent spacing.

D. Attaching flexible venting to vertical termination assemblies.

1. When using Simpson pipe, an MHSC flex-to-pipe adapter and/or rigid pipe section(s) is required to connect the flexible vent assembly to the vertical termination by using three self-penetrating screws.
2. Review *Figure 37* and corresponding instructions for proper overlap, clamp and screw placement.
3. Three each self-penetrating screws are drilled opposite one another and below the gear clamp.
4. Use only listed and approved terminations and accessories, installed per the installation instructions and *Figure 36*.

E. Installing flexible venting to horizontal termination assemblies.

1. Connect the 4" flexible vent to the horizontal termination. *Figure 38*
2. Slide termination cap adapter ring over the termination cap's outside pipe and secure with three screws.
3. Connect the 7" flexible vent to the termination adapter ring. *Figure 38*
4. Review *Figure 38* for proper overlap and clamp placement.
5. Three each self-penetrating screws are drilled opposite one another and below the gear clamp.
6. Use only listed approved terminations and accessories, installed per the termination instructions and *Figure 38*.

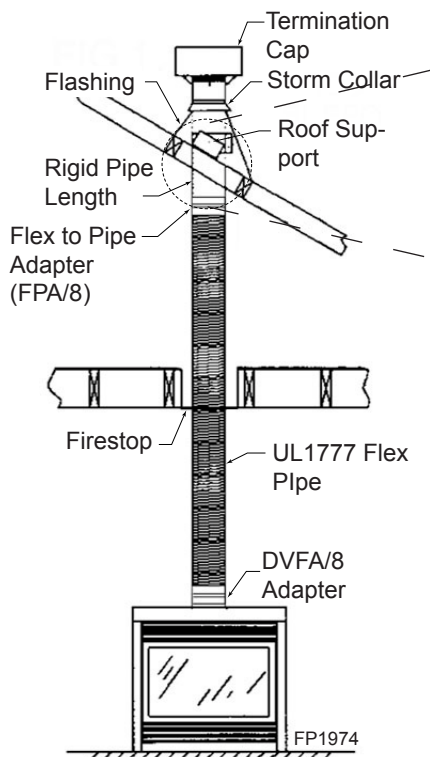

Figure 36 - Typical Vertical Flex Vent Installation

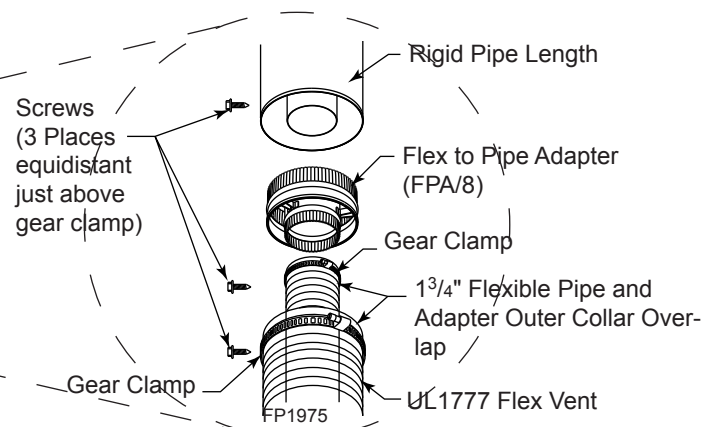

Figure 37 - Typical Pipe Connection

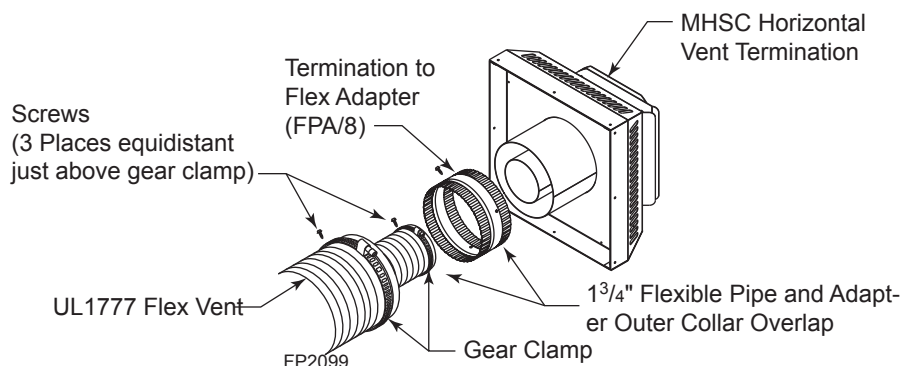

Figure 38 - Typical Horizontal Flex Vent Installation

CHECK GAS TYPE

Use proper gas type for the fireplace you are installing. If you have conflicting gas type, do not install fireplace. See dealer where you purchased the fireplace for proper fireplace for your gas type or conversion kit.

INSTALLING GAS PIPING TO FIREPLACE / BURNER SYSTEM LOCATION**WARNING**

A qualified installer or service person must connect appliance to gas supply. Follow all local codes.

CAUTION

For propane/LP units, never connect fireplace directly to the propane/LP supply. This burner system requires an external regulator (not supplied). Install the external regulator between the burner system and propane/LP supply.

INSTALLATION ITEMS NEEDED

Before installing fireplace and burner system, make sure you have the items listed below.

- External regulator (supplied by installer)
- Sealant (resistant to propane/LP gas)
- Sediment trap (recommended)
- Tee joint
- approved flexible gas line with gas connector (if allowed by local codes — not provided)
- Piping (check local codes)
- Equipment shutoff valve*
- Pipe wrench
- Test gauge connection*

* A CSA design-certified equipment shutoff valve with 1/8" NPT tap is an acceptable alternative to test gauge connection. Purchase the CSA design-certified equipment shutoff valve from your dealer.

For propane/LP connections only, the installer must supply an external regulator. The external regulator will reduce incoming gas pressure. You must reduce incoming gas pressure to between 11 and 13 inches of water. If you do not reduce incoming gas pressure, burner system regulator damage could occur. Install external regulator with the vent pointing down as shown in *Figure 39*. Pointing the vent down protects it from freezing rain or sleet.

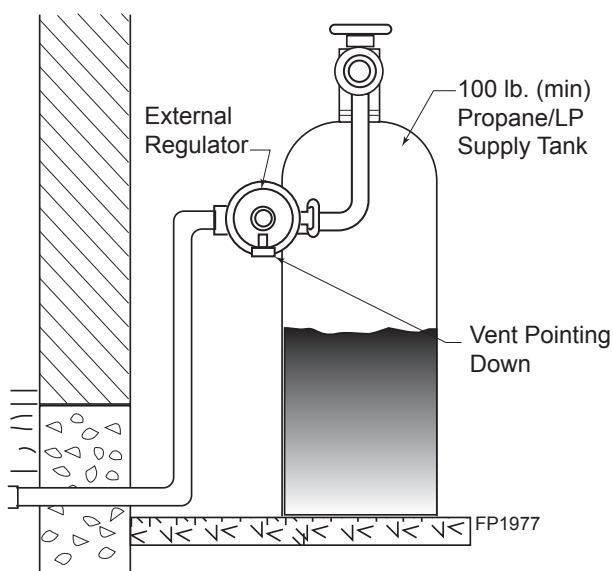

Figure 39 - External Regulator with Vent Pointing Down (Propane/LP Only)

CAUTION

Use only new black iron or steel pipe. Internally tinned copper or copper tubing can be used per National Fuel Code, section 2.6.3, providing gas meets hydrogen sulfide limits, and where permitted by local codes. Gas piping system must be sized to provide minimum inlet pressure (listed on data plate) at the maximum flow rate (BTU/hr). Undue pressure loss will occur if the pipe is too small.

When using copper or flex connectors use only fittings approved for gas connections. The gas control inlet is 3/8" NPT.

WARNING
 Only persons licensed to work with gas piping may make the necessary gas connections to this appliance.

CAUTION
 A manual shutoff valve must be installed upstream of the appliance. Union tee and plugged 1/8" NPT pressure tapping point should be installed upstream of the appliance. *Figure 40*

NOTE : The gas line connection may be made using 1/2" rigid tubing or an approved flex connector. Since some municipalities have additional local codes it is always best to consult your local authorities and the current edition of the National Fuel Gas Code ANSI.Z223.1, NFPA54. In Canada CSA B149 (1 or 2) Installation Code.

A listed manual shutoff valve must be installed upstream of the appliance. Union tee and plugged 1/8" NPT pressure tapping point should be installed upstream of the appliance. *Figure 40*

IMPORTANT: Install main gas valve (equipment shutoff valve) in an accessible location. The main gas valve is for turning on or shutting off the gas to the fireplace.

Check your building codes for any special requirements for locating equipment shutoff valve to fireplaces.

Apply pipe joint sealant lightly to male threads. This will prevent excess sealant from going into pipe. Excess sealant in pipe could result in clogged burner system valves.

CAUTION
 Use pipe joint sealant that is resistant to liquid petroleum (LP) gas.

We recommend that you install a sediment trap/drip leg in supply line as shown in *Figure 40*. Locate sediment trap/drip leg where it is within reach for cleaning. Install in piping system between fuel supply and burner system. Locate sediment trap/drip leg where trapped matter is not likely to freeze. A sediment trap collects moisture and contaminants and keeps them from going into the burner system gas controls. If sediment trap/drip leg is not installed or is installed wrong, burner system may not run properly.

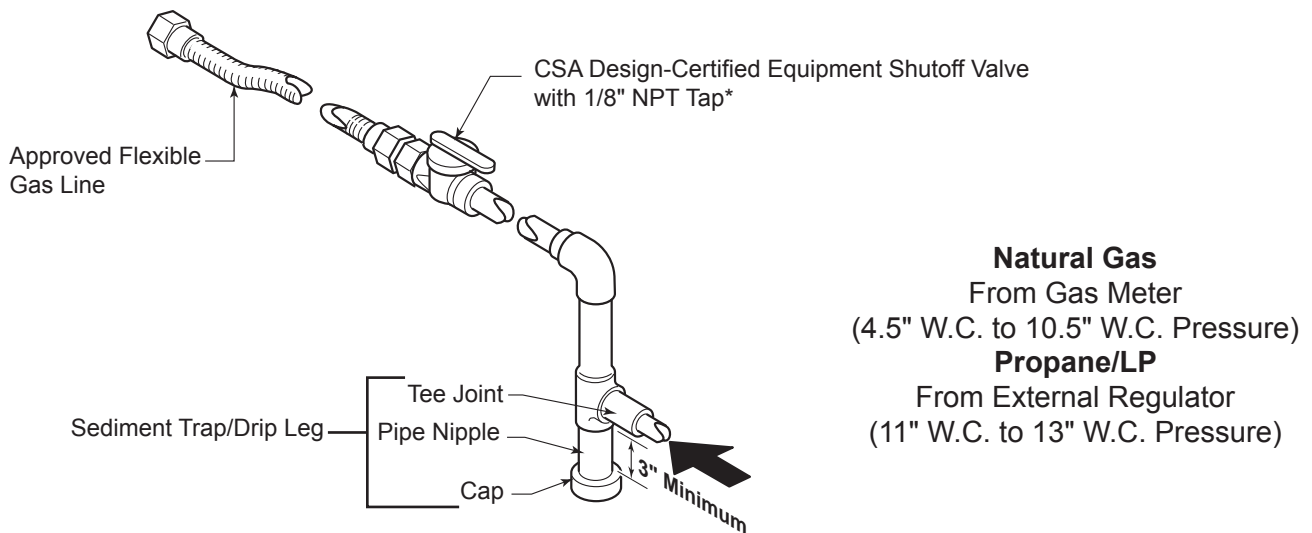

Figure 40 - Gas Connection

1. Check gas type. The gas supply must be the same as stated on the appliance's rating decal. If the gas supply is different from the fireplace, **STOP!** Do not install the appliance. Contact your dealer immediately.
2. To ease installation, a 30" (762 mm) flex line with manual shut-off valve has been provided with on this appliance. Install and attach 1/2" gas line onto shut-off valve.
3. After completing gas line connection, purge air from gas line and test all gas joints from the gas meter to the fireplace for leaks. Use a solution of 50/40 water and soap or a gas sniffer.
4. To adjust flame height, turn HI/LO knob to HI to get maximum pressure to burner. Turn HI/LO knob to LO to get minimum pressure.
5. To check gas pressures at valve, turn captured screw counter clockwise 2 or 3 turns and then place tubing to pressure gauge over test point. Turn unit to high. *Figure 41*. After taking pressure reading, be sure and turn captured screw clockwise firmly to reseal. Do not over torque. Check test points for gas leaks.

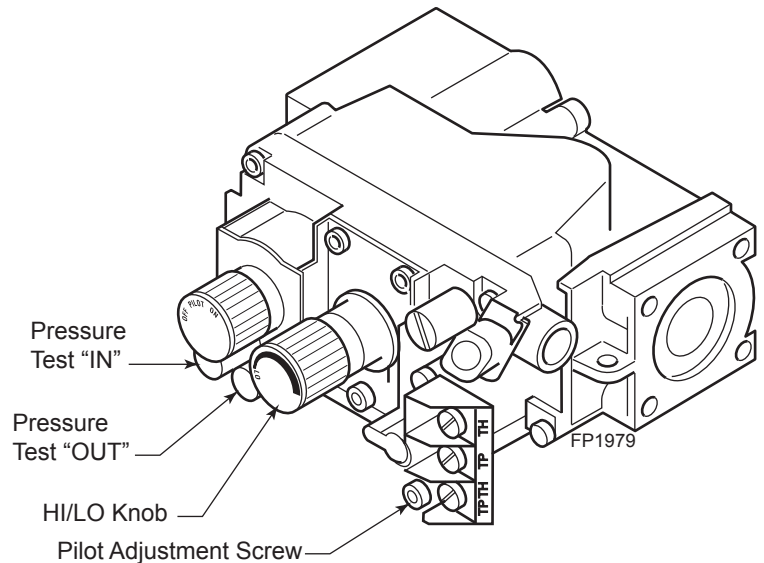

Figure 41 - Gas Pressure Check at Gas Valve

WARNING

Do not use open flame to check for gas leaks.

ELECTRICAL WIRING (Millivolt)

This fireplace will work without any electrical supply. Electricity is only needed to operate blower.

NOTE: *If installed in mobile home, fireplace must be bolted securely to floor.*

WARNING

Electrical connections should only be performed by a qualified, licensed electrician. Main power must be off when connecting to main electrical power supply or performing service. All wiring shall be in compliance with all local, city, and state codes. The appliance, when installed, must be electrically grounded in accordance with local codes, or in the absence of local codes, with the *National Electrical Code ANSI/ NFPA 70 (latest edition)* and *Canadian Electrical Code, CSA C22.1*.

CAUTION

Label all wires before disconnecting when servicing controls. Wiring errors can cause improper and dangerous operation.

Verify proper operation after servicing.

REMOTE WALL MOUNTED SWITCH

A remote wall switch and up to fifteen (15) feet of 18 Ga. wire may be used with this appliance. Attach the wall switch in a junction box at the desired location on the wall. *Figure 42.* Do not extend beyond the wall switch wire length provided.

NOTE: Extended lengths of wire may cause the fireplace not to function properly. Longer length of wire is permitted if the wire is made out of larger gauge (diameter) wire. Always check with local code.

WARNING Do not connect wall switch to (110V) circuit.

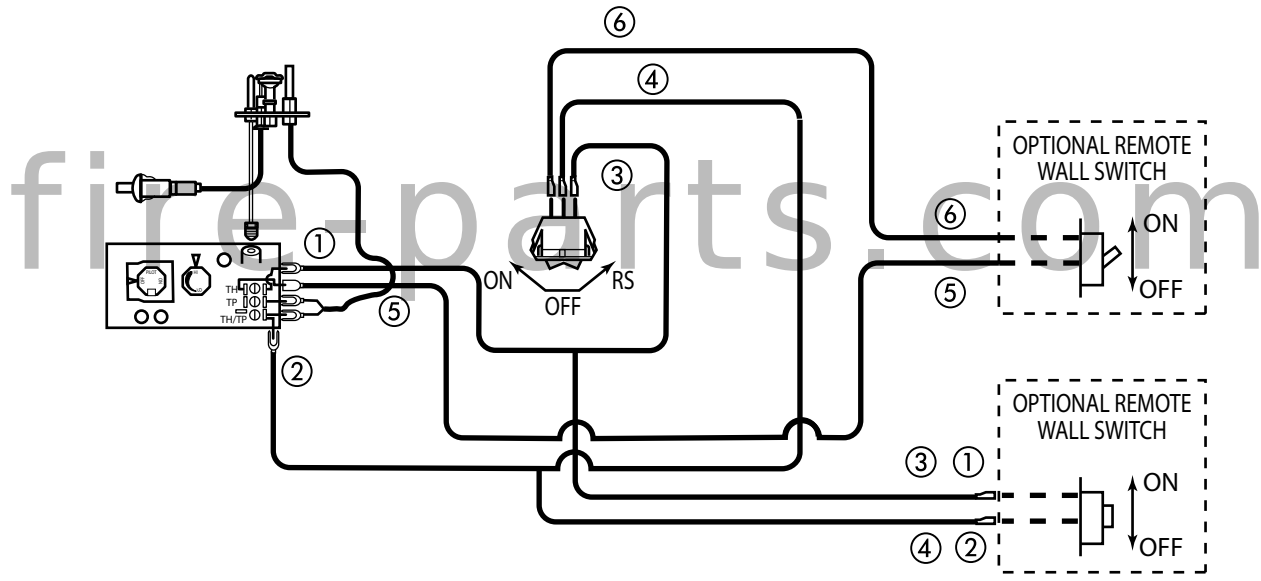

Figure 42 - Wiring Diagram for Wall Switch

ELECTRONIC PILOT IGNITION WIRING

WARNING

Do not connect 110-120 VAC to the Remote Wall Switch. The appliance will malfunction.

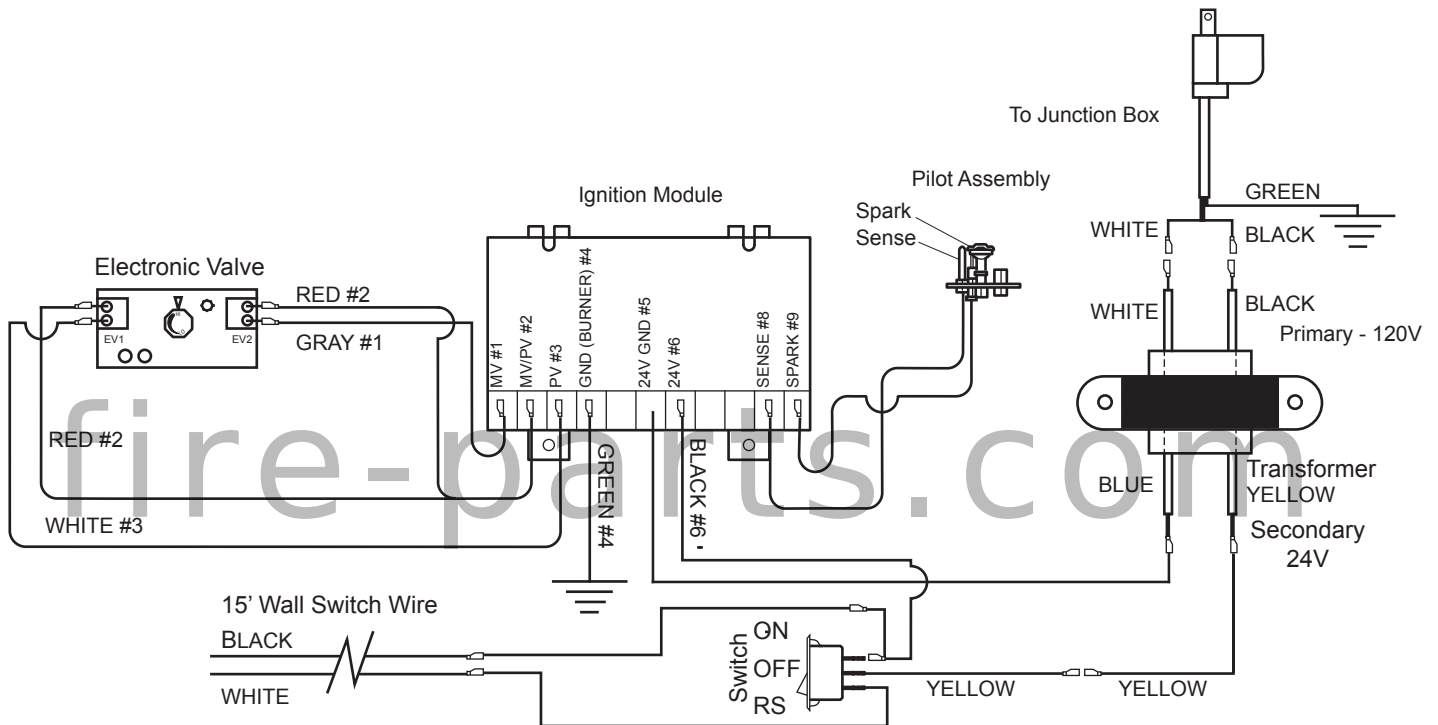

Figure 43 - Remote Wall Switch Wiring Diagram

REMOTE WALL SWITCH

Position the wall switch. Do not extend beyond the 15 feet of wire.

OPTIONAL DC REMOTE SYSTEMS

These instructions replace the section entitled *Hearth Mount* in the Millivolt hand held remote instructions supplied with the remote.

1. Plug in remote connector wire to remote receiver.
2. Connect the wire terminal from the remote receiver. This replaces the 15' wall switch connection to the switch. *Figure 43*.
3. Mount remote control receiver at junction box (for your wall switch).

OPTIONAL FAN/BLOWER SYSTEMS (BLOT)

The junction box for the fan/blower systems has been factory installed. This system requires that 110-120 VAC to be wired to the factory installed junction box before the fireplace is permanently installed. *Figure 44*

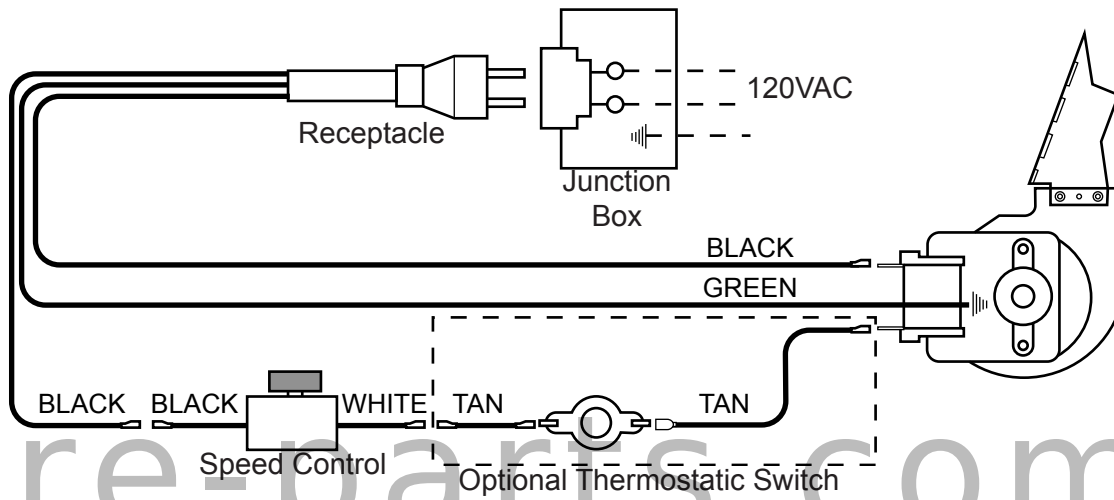

Figure 44 - Blower Wiring Diagram

FOR YOUR SAFETY READ BEFORE LIGHTING**WARNING**

If you do not follow these instructions exactly, a fire or explosion may result causing property damage, personal injury or loss of life.

- A.** This appliance is equipped with a pilot which must be lit with built-in piezo ignitor while following these instructions exactly.
- B.** BEFORE OPERATING smell all around the appliance area for gas. Be sure to smell next to the floor because some gas is heavier than air and will settle on the floor.

WHAT TO DO IF YOU SMELL GAS:

- Turn off all gas to the appliance.
 - Open windows.
 - Do not attempt to light any appliance.
 - Do not touch any electric switch; do not use any phone in your building.
 - Immediately call your gas supplier from a neighbor's phone. Follow the gas supplier's instructions.
 - If you cannot reach your gas supplier, call the fire department.
- C.** Use only your hand to push in, or turn the gas control knob. Never use tools. If the knob will not push in or turn by hand, don't try to repair it. Call a qualified service technician. Force or attempted repair may result in a fire or explosion.
- D.** Do not use this appliance if any part of it has been under water. Immediately call a qualified service technician to inspect the appliance and to replace any part of the control system and any gas control that has been under water.

LIGHTING PILOT FOR THE FIRST TIME**INITIAL LIGHTING**

Purge air from the supply line as follows:

- Open main shutoff valve.
- Unscrew main pressure test point.
- Leave inlet test screw open until gas comes in.
- When gas is flowing, tighten inlet screw immediately.

WARNING

Never use an open flame to check for gas leak.

LEAK TESTING

1. Follow the pipe from the gas supply line connection to the gas valve. Check connection for leaks with soap and water mixture.
2. Next check for gas leaks at the burner with soap and water mixture.
3. Check the pilot for gas leaks with soap and water mixture.

LIGHTING PILOT FOR THE FIRST TIME

APPROVED LEAK TESTING METHOD

You may check for gas leaks with the following methods only:

- Soap and water solution
- An approved leak testing spray
- Electronic sniffer

DANGER

Never check for gas leak with open flame!

WARNING

If using a soap and water solution to test for leaks, **DO NOT** spray solution onto control body.

NOTE: Remove any excessive pipe compound from the connections. Excessive pipe compound can set off electronic sniffers.

Check for gas leaks in each of the following locations:

- Pipe from the gas supply line connection to the gas valve
- Burner connections
- Pilot
- Each joint or connection
- Field made joints / gas shutoff valve
- Factory made joints
- All joints on valve and control body

LIGHTING PILOT

WARNING

The control has an interlock device that does not allow the lighting of the fireplace up to the moment the safety device of the flame has not interrupted the gas flow. After that period of time (when the magnet is closed), it is possible to start the lighting operation.

The gas control knob is designed to be operated by hand. **DO NOT** use any tools during this operation. Damaged knobs may result in serious injury.

1. Depress and turn knob counterclockwise  to pilot position.
2. Depress fully and hold pilot gas knob. Depress piezoigniter as many times as needed to ignite pilot. Keep knob fully depressed for a few seconds. Release and check that pilot continues to burn.

If the pilot does not stay lit, repeat steps 1 and 2.

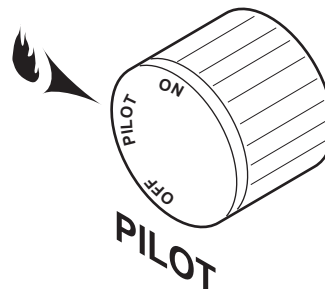

Figure 45 - Pilot Position

Continued on next page

LIGHTING BURNER

MAIN BURNER SWITCH

The "ON/OFF/RS" switch for the main burner can be found behind door of the fireplace. This switch allows you to turn on and to turn off the main burner without using the gas valve knob. Make sure the button is in the "ON" position to light the main burner. *Figure 46*

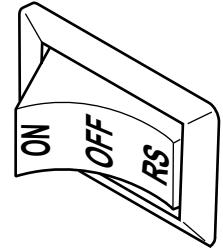



Figure 46 - On/Off/RS Switch

LIGHTING THE BURNER

Depress and turn the knob counterclockwise  to the "ON" position. *Figure 47*. It will take less than four (4) seconds for the burner to ignite.

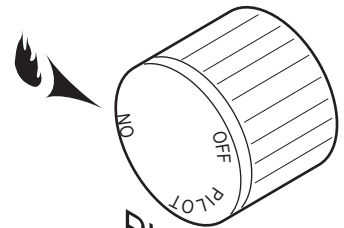

Figure 47 - On Position

PILOT POSITION

Depress and turn knob to pilot position to keep burner off while maintaining the pilot light. *Figure 48*

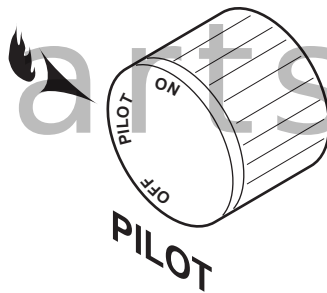



Figure 48 - Pilot Position

TO TURN OFF GAS

Depress and turn knob clockwise  to "OFF" position. *Figure 49*

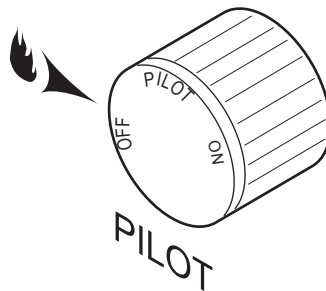

Figure 49 - Off Position

FOR YOUR SAFETY READ BEFORE LIGHTING

- A. This appliance is equipped with an ignition device (Piezo) which automatically lights the pilot. Do NOT try to light the burner by hand.
- B. BEFORE OPERATING smell all around the appliance area for gas. Be sure to smell next to the floor because some gas is heavier than air and will settle on the floor.

WARNING

If you do not follow these instructions exactly, a fire or explosion may result causing property damage, personal injury or loss of life.

WHAT TO DO IF YOU SMELL GAS:

- Turn off all gas to the appliance.
 - Open windows.
 - Do not attempt to light any appliance.
 - Do not touch any electric switch; do not use any phone in your building.
 - Immediately call your gas supplier from a neighbor's phone. Follow the gas supplier's instructions.
 - If you cannot reach your gas supplier, call the fire department.
- C. Turn off all electric power to appliance.
 - D. Do not use this appliance if any part of it has been under water. Immediately call a qualified service technician to inspect the appliance and to replace any part of the control system and any gas control that has been under water.

WARNING

Never use an open flame to check for gas leak.

LIGHTING ELECTRONIC IGNITION

1. **STOP!** Read the safety information above.
2. Make sure all power to unit is turned off.
3. Set thermostat to lowest setting.
4. This appliance is equipped with an ignition device which automatically lights the burner. Do not try to light the burner by hand.
5. Turn on all electric power to appliance.
6. Set thermostat to desired setting.
7. Turn RS-OFF-ON rocker switch to "ON".
8. If the appliance will not operate, follow the instruction *To Turn Off Gas* below and call your service technician or gas supplier.

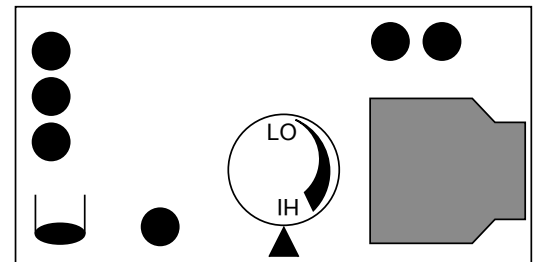

Figure 50 - Electronic Gas Valve

TO TURN OFF GAS

1. Open lower door.
2. Turn RS-OFF_ON rocker switch to "OFF".
3. Turn off all electric power to the appliance if service is to be performed.
4. Close lower door.

SIGNATURE COMMAND - CHECK GAS PRESSURE and ELECTRICAL INSTALLATION

1. Check gas type. The gas supply must be the same as stated on the appliance's rating decal. If the gas supply is different from the fireplace, **STOP!** Do not install the appliance. Contact your dealer immediately.
2. To ease installation, a 24" (610 mm) flex line with manual shut-off valve has been provided with on this appliance. Install and attach 1/2" gas line onto shut-off valve.
3. After completing gas line connection, purge air from gas line and test all gas joints from the gas meter to the fireplace for leaks. Use a solution of 50/50 water and soap solution or a gas sniffer.
4. To check gas pressures at valve, turn captured screw counter clockwise 2 or 3 turns and then place tubing to pressure gauge over test point. Turn unit to high. *Figure 51*. After taking pressure reading, be sure and turn captured screw clockwise firmly to reseal. Do not over torque. Check test points for gas leaks.

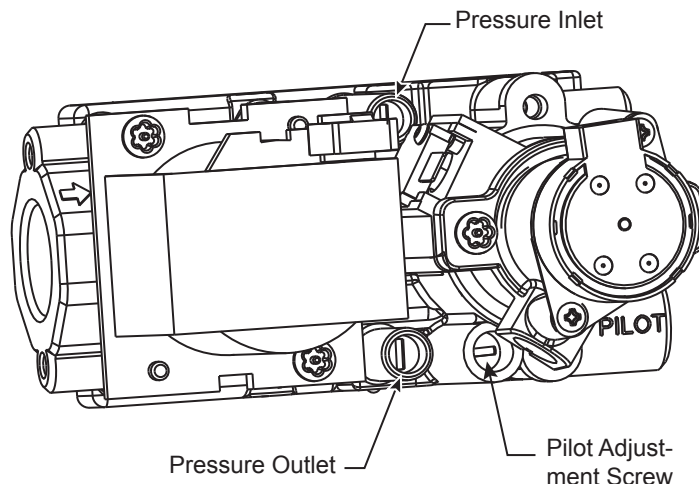

Figure 51 - Signature Command Valve

WARNING

Do not use open flame to check for gas leaks.

ELECTRICAL WIRING

This fireplace will work without any electrical supply. Electricity is only needed to operate blower.

NOTE: *If installed in mobile home, fireplace must be bolted securely to floor.*

WARNING

Electrical connections should only be performed by a qualified, licensed electrician. Main power must be off when connecting to main electrical power supply or performing service. All wiring shall be in compliance with all local, city, and state codes. The appliance, when installed, must be electrically grounded in accordance with local codes, or in the absence of local codes, with the *National Electrical Code ANSI/ NFPA 70 (latest edition)* and *Canadian Electrical Code, CSA C22.1*.

CAUTION

Label all wires before disconnecting when servicing controls. Wiring errors can cause improper and dangerous operation.

Verify proper operation after servicing.

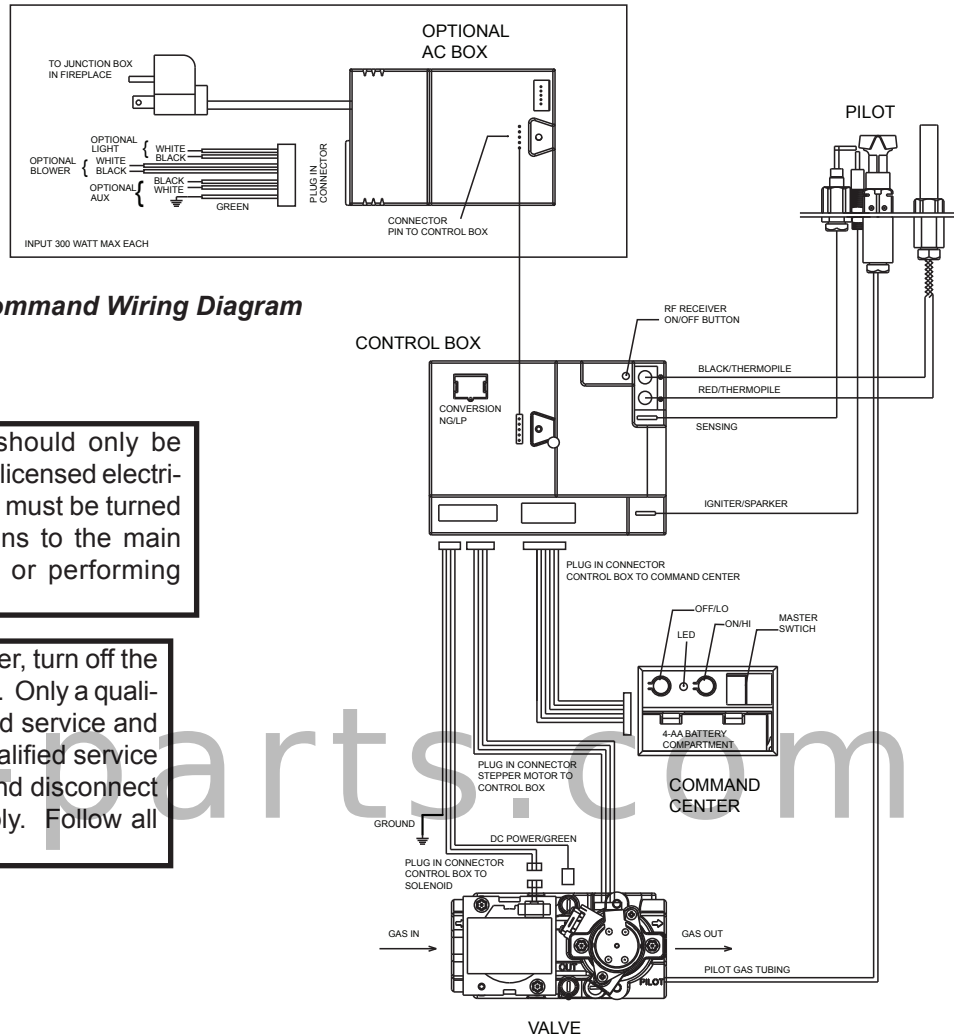

Figure 52 - Signature Command Wiring Diagram

CAUTION

Electrical connections should only be performed by a qualified, licensed electrician. Main power supply must be turned off before connecting fans to the main electrical power supply or performing service.

WARNING

Before installing the blower, turn off the fireplace and allow to cool. Only a qualified service person should service and repair the fireplace. A qualified service person should connect and disconnect the fireplace to gas supply. Follow all local codes.

COMMAND CENTER WALL INSTALLATION

The command center may be mounted on the wall with the use of the SCSWEK Kit (15ft. cable, junction box, wall cover).

Mount the junction box provided at the desired location on the wall. Do not extend beyond the 15 ft. wire cable provided.

Route the wire from junction box to lower control area at bottom of fireplace. Unplug the 12" cable from control box and command center. Plug the 15 ft. extension cable into the control box. Remove command center from the fireplace and plug the other end of the extension cable into the command center. Snap on wall cover provided and screw to junction box.

OPTIONAL FAN/BLOWER SYSTEM (BLOTSC)

Installation Instructions

Wiring

1. Before installing the blower, wire the receptacle into an electrical circuit. This should be done before framing the fireplace. Wire with minimum 60° C wire in accordance with prevailing codes.
2. Remove the external junction box cover by removing the screw from the left side of the outside firebox wall. Junction box was installed at the factory.
3. The junction box cover has a factory installed "romex" style strain relief connector. After connecting the wires, route the wire leads through this connector. Refer to the wiring diagram in *Figure 53*.

Before Installing the Blower

1. Always turn off the gas supply and allow the unit to cool down before proceeding.
2. Clean the inside of the firebox (wall and floor), where the blower and wires will be installed. Make sure the firebox wall and floor are clean and dry before mounting the blower.

Installing the Blower

1. Remove the lower access panel by pulling up and away from unit.
2. Remove glass frame by releasing the two (2) latches (500 and 600 models have three (3) latches) below the firebox opening and lifting glass frame up and away from unit.
3. Use the supplied Velcro on the blower and the magnetic strips to secure the blower to the firebox wall and floor. *Figure 54*
4. Remove the tape from the back of the Velcro strips, slide the blower through lower access door and position on the inside back firebox wall. The blower should be centered with the rear blower discharge vent facing up (pointing up between the inside firebox wall and inner combustion wall). The blower should be flat against the firebox back wall. *Figure 55*
5. For 300 models, the air shield can be removed. *Figure 54*
6. Align the connector pin on the AC box to the control box and gently push them together using the guiding block as a guide. *Figure 56*

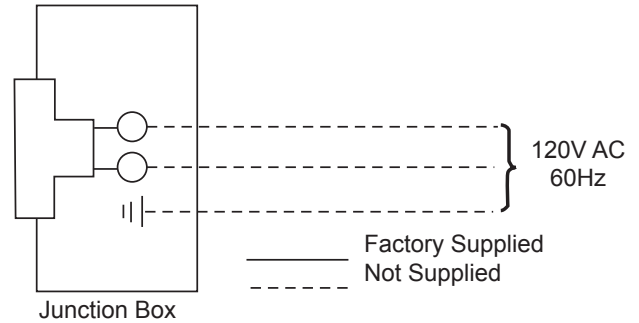
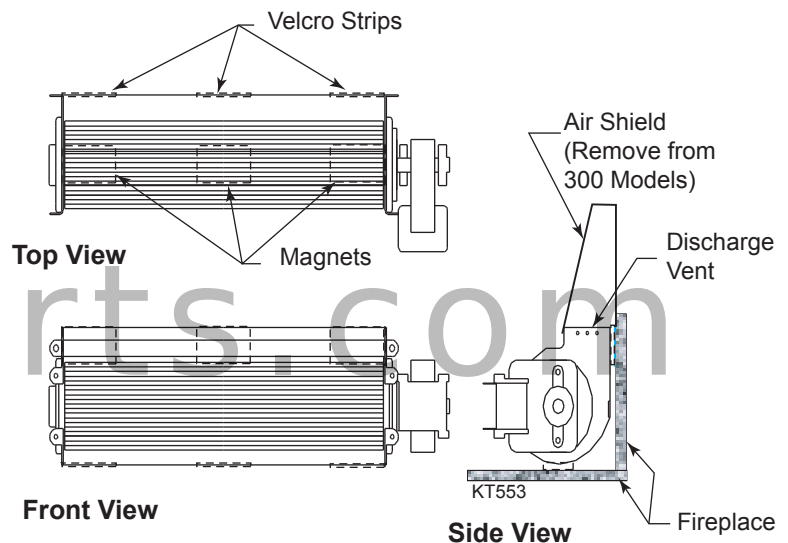
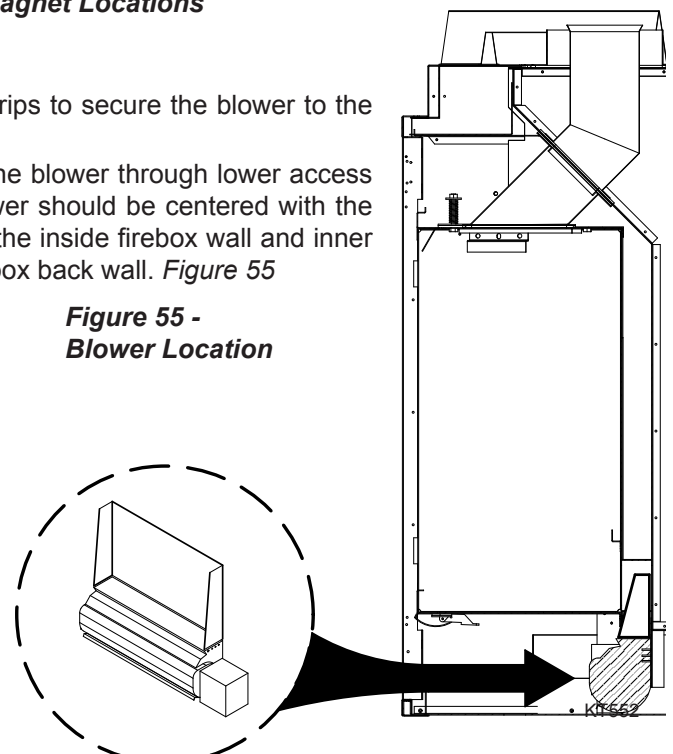

Figure 53 - Junction Box Wiring Diagram



**Figure 54 -
Velcro, Magnet Locations**

**Figure 55 -
Blower Location**



NOTE

Keep wires away from combustion chamber and blower wheel.

7. Secure the AC box to the control box using screw provided. *Figure 56*
8. Plug in wiring harness to the back of AC box.
9. Connect the blower according to the wiring diagram. *Figure 57* **NOTE:** Be sure to use the wires marked 'Blower'.
10. Replace glass frame .
11. Plug the AC box plug to the junction box. *Figure 57*
12. To test blower operation. Turn the fireplace on. Turn blower on. The blower should turn on within five (5) minutes. Refer to the operating instructions on Signature Command remote control for complete operation instructions.

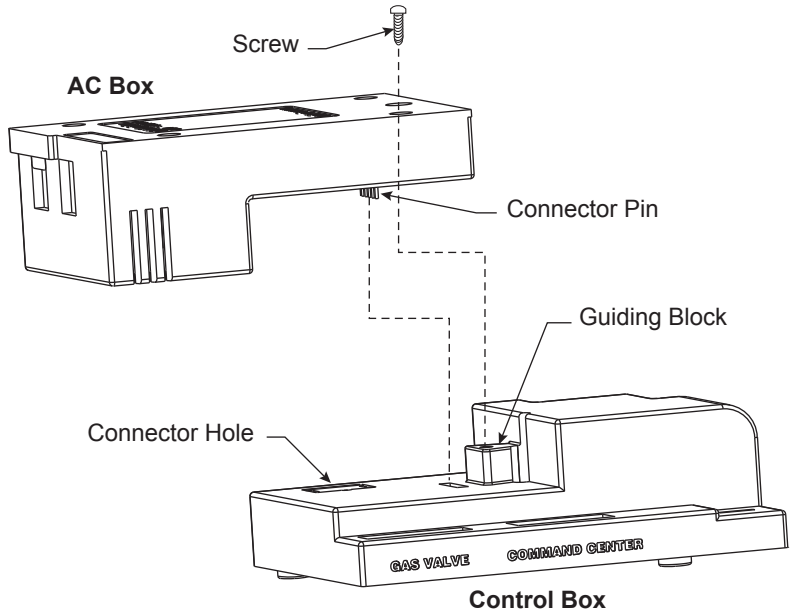

Figure 56 - Connect AC Box to Control Box

Finishing

Re-install the lower access panel.

fire-parts.com

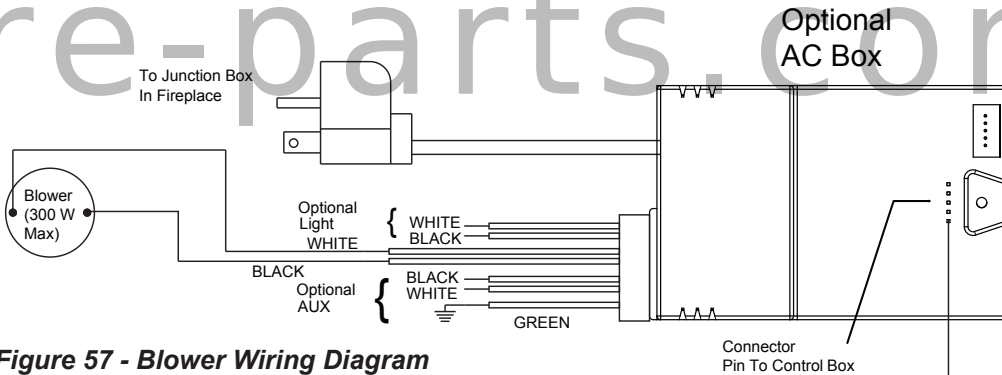
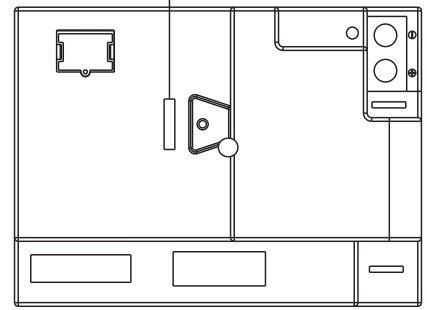

Figure 57 - Blower Wiring Diagram

Control Box



NOTE The black and white wires on the AC box wiring harness are marked 'Blower', 'Light' and 'Aux'. It is important to use the wires marked 'Blower' or the control will not work correctly.

WARNING Electrical Grounding Instructions: This appliance is equipped with a three-prong (grounding) plug for your protection against shock hazard and should be plugged directly into a properly grounded three prong receptacle.

WARNING Electrical connections should only be performed by a qualified licensed electrician. Main power supply must be turned off before connecting the fan to the main electrical power supply or performing service.

FOR YOUR SAFETY READ BEFORE LIGHTING**WARNING**

If you do not follow these instructions exactly, a fire or explosion may result causing property damage, personal injury or loss of life.

- A. This appliance is equipped with an ignition device which automatically lights the pilot. Refer to the instructions for match lighting.
- B. BEFORE OPERATING smell all around the appliance area for gas. Be sure to smell next to the floor because some gas is heavier than air and will settle on the floor.

WHAT TO DO IF YOU SMELL GAS:

- Do not attempt to light any appliance.
 - Do not touch any electric switch; do not use any phone in your building.
 - Immediately call your gas supplier from a neighbor's phone. Follow the gas supplier's instructions.
 - If you cannot reach your gas supplier, call the fire department.
- C. Use only your finger to push in the master switch. Never use tools. If the switch will not function by hand, do not try to repair it. Call a qualified service technician. Force or attempted repair may result in a fire or explosion.
 - D. Do not use this appliance if any part of it has been under water. Immediately call a qualified service technician to inspect the appliance and to replace any part of the control system and any gas control that has been under water.

continued on next page

OPERATING INSTRUCTIONS

1. **STOP!** Read the safety information above.
2. This appliance is equipped with an ignition device which automatically lights the burner. Do not try to light the burner by hand.
3. With five (5) minutes to clear out any gas. Then smell for gas, including near the floor. If you smell gas, **STOP!** Follow "B" in the safety information on page 38. If you do not smell gas, go to next step.
4. Install four (4) "AA" batteries (provided in your Homeowner's Manual bag) into the command center box. Make sure the batteries orientation match.
5. Press the master switch to the "ON" (-) position. Within eight (8) seconds it will beep once. This indicates the system is ready.
6. Press "ON " button. Sparker will spark and pilot flame will light.
7. Once pilot flame is established, the main burner flame will light automatically.
8. If the pilot will not stay lit after several tries, turn the master switch to "OFF" and call your service technician or gas supplier.

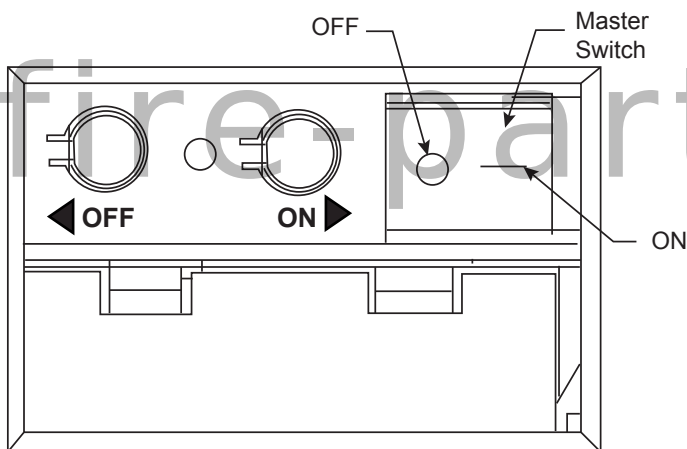

Switch Box

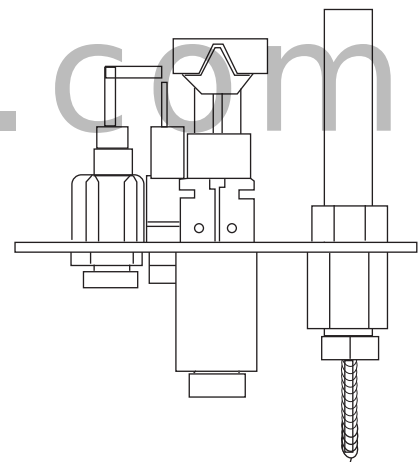

TO TURN OFF GAS TO APPLIANCE

1. Turn master switch to "OFF".
2. Turn off all electrical power to the appliance if service is to be performed.

SIGNATURE COMMAND SYSTEM OPERATION INSTRUCTIONS

FEATURES

Command Center

- Easy Access Function Operation and System Configuration
- Operation Confirmation/Fault Diagnostic Indications (LED/Buzzer)
- ON/OFF/HI/Low Operation

Control Board

- Electronic Ignition
- Pilot Lockout safety feature
- Electric Power Regeneration from Thermopile to save battery
- 6-hour Automatic Shut Down Option
- Convenient NG/LP Gas Type Conversion
- Standing Pilot/Intermittent pilot Conversion
- Previous settings Restoration Ability
- Uninterrupted Operation During Power Outage (Automatic Battery Backup)
- ON/OFF RF Remote Receiver
- Optional Transmitter Learn Capability

AC Interface Board (Optional)

- Easy Snap-on Design
- Embedded Compact 120 VAC Adapter with Auto Battery Back up Feature
- Remote Controlled Blower, Lighting, and Auxiliary AC Outputs

Transmitter (Optional)

	RFSC	RTSC	RMSC
Three Flame Height Settings	X	X	X
Low battery Indication for Transmitter	X	X	X
Child Proof Lock-out	X	X	X
LCD Backlight	X	X	X
Security Codes	X	X	X
Thermostatic Control Mode	X	X	--
Three Brightness Settings for Lights	X	--	--
Three Speed Control for Blower	X	--	--
On/Off Auxiliary	X	--	--
Programmable Timer to turn blower on and off	X	--	--

BATTERY INSTALLATION

The Command Center uses four (4) "AA" batteries.

To Install Batteries:

1. Press down the battery door tabs and pull out to remove battery door.
2. Install the batteries as indicated on Command Center.
3. Close battery door by snapping in place.
4. When the four (4) batteries are installed the system is ready for use.
5. The batteries should be replaced when the LED indicates low battery.

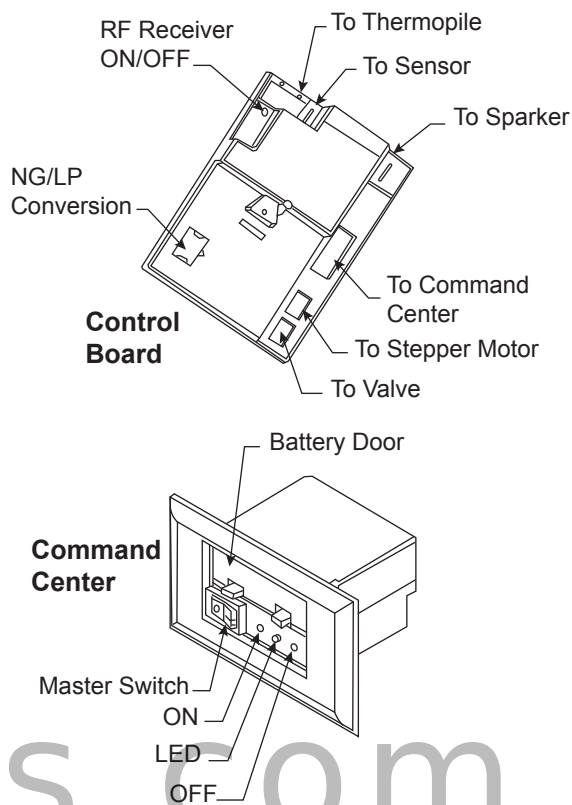

Figure 58 - Signature Command System Components

SIGNATURE COMMAND SYSTEM OPERATION INSTRUCTIONS

SYSTEM CONFIGURATION/SETUP

System configuration/setup is done on the Command Center.

Intermittent/Standing Pilot Setup (Default intermittent)

1. Holding the ON button on the Command Center while turning on the master switch will toggle between standing pilot and intermittent pilot.
2. After the above operation, one beep (for standing pilot) or two beeps (for intermittent pilot) will be given as confirmation.

Six-hour Safety Shutdown Option (Default ON)

1. The system comes preset from the factory with a six (6) hour shutdown from its last command of operation. This is done to prevent the fireplace from continuing to operate if unattended. You may disable this feature if you wish.

NOTE: By disabling this feature, your fireplace may continue to operate unattended.

2. When the master switch is in the ON position (“-”), pressing the ON button and the OFF button on the Command Center simultaneously will toggle between enabling and disabling the six-hour shutdown option.
3. After the above operation, one beep (for enabling the six-hour shutdown option) or two beeps (for disabling the six-hour shutdown option) will be given as confirmation.

Remote Transmitter Learn Function (Default OFF)

1. The RF receiver button located on the control board must be in the on position before the learn function can begin. Use paper clip to depress button. One beep for RF receiver ON or two beeps for RF receiver OFF will be given as confirmation.
2. After the RF receiver is on, holding the OFF button on the Command Center while turning on the master switch will activate the learn function for the transmitter.
3. After the above operation, two beeps will be given and the green LED on the Command Center will flash for 10 seconds.
4. During the 10 seconds, press the OFF button on a transmitter to learn. Another two beeps will be given to confirm a successful learning.

Shutting Off the Standing Pilot

To shut off the standing pilot for service or summer shut down, press and hold the ON button on the Command Center for 3 seconds when the master switch is in the ON position (“-”) and the main burner is off.

Note: Pilot will resume the next time system is turned on.

Key Combinations for System Settings

Function	Operation	Default Setting
Intermittent/Standing Pilot Setup	Hold the ON ▲ button while turning on the master switch (Beep once for standing pilot, twice for intermittent pilot)	Intermittent Pilot
Standing Pilot Temp. Shutoff	Hold the ON ▲ button 3 seconds (when the master switch on the main burner is off)	
RF Remote Receiver On/Off	Push the RF receiver On/Off button on the control board Beep once for ON and beep twice for OFF	RF OFF
Learn Remote Transmitter	Hold the OFF ▼ button while turning on the master switch (Beep twice then press any handheld remote button)	
6-hour safety shutdown setup	Press the ON ▲ button and OFF ▼ button simultaneously (Beep once for ON, twice for OFF)	ON

SIGNATURE COMMAND SYSTEM OPERATION INSTRUCTIONS

FUNCTIONS/OPERATION

Turning on the fireplace

1. Turn on the master switch and wait for a beep.
2. Press the ON button on the Command Center. Pilot will light and burner will come on High setting.

Pilot Safety Lockout Function

1. If the pilot doesn't light after sparking for 30 seconds, pilot trial lockout happens. The LED on the Command Center flashes Green once every 2 seconds, until reset.
2. If the pilot flame is lost during normal operation, flame loss lockout happens. The LED on the Command Center flashes Red-Green once every 2 seconds, until reset.
3. Turning the master switch OFF, then ON again will reset the system.

Flame Height Control

1. Press the ON button (on the Command Center) once to turn on the main burner with maximum flame height.
2. Press the OFF button to decrease flame height. The first two presses will decrease the flame height to medium and low.
3. The third press on OFF will turn off the main burner. In standing pilot configuration, the pilot will stay; in intermittent pilot configuration, the pilot will be shut off.

Turning the Fireplace Off

There are three ways to turn the fireplace off. (This will turn the entire system OFF.)

1. Flip the master switch to the off ("O") position
2. Press the OFF button to Medium, Low, then Off.
3. Hold the OFF button anytime for three seconds. This command of OFF will remember all last settings before turning off. The next time the fireplace is turned on, all settings will resume.

Command Center Operations:

The following functions are available on the Command Center.

Function	Operation
Power Up	Flip the master switch to the ON ("I") position to power up the system
Fireplace ON	Press the ON ▲ button on the Command Center to turn the fireplace on
Fireplace OFF	Flip the master switch to the OFF ("o") position OR press the OFF ▼ button 3 times OR hold the OFF ▼ button 3 seconds
Flame Height Up	Press the ON ▲ button once to turn on the fireplace with maximum flame height
Flame Height Down	Press the OFF ▼ button to lower the flame height to Medium and Low

Self Diagnostics Chart:

The Command Center has a self-diagnostic LED enabling you to troubleshoot problems and potentially avoid a service call. Please refer to the charts below for indicator reference.

Fault	LED Indication
Conversion Cover Missing	One RED (1 time)
Spark Fail	Two RED (1 time)
No Sensor Signal	Three RED (1 time)
Pilot Lockout - trial	One GREEN, every 2 sec. (until manual reset)
Pilot Lockout - flame loss	One RED-GREEN, every 2 sec. (until manual reset)
Low Battery	One RED, every 10s (continuously)
No or Low Thermopile Power	Two RED, every 10s (continuously)
Learning	GREEN Flashes, every 1 sec. (for 10 sec.)
AC Power On	GREEN solid

GLASS FRAME REMOVAL

1. Release two clamps on bottom of fireplace. *Figure 59*
2. Tilt glass frame out and lift glass frame up until it clears three tabs on top of fireplace.
3. Set glass frame aside.

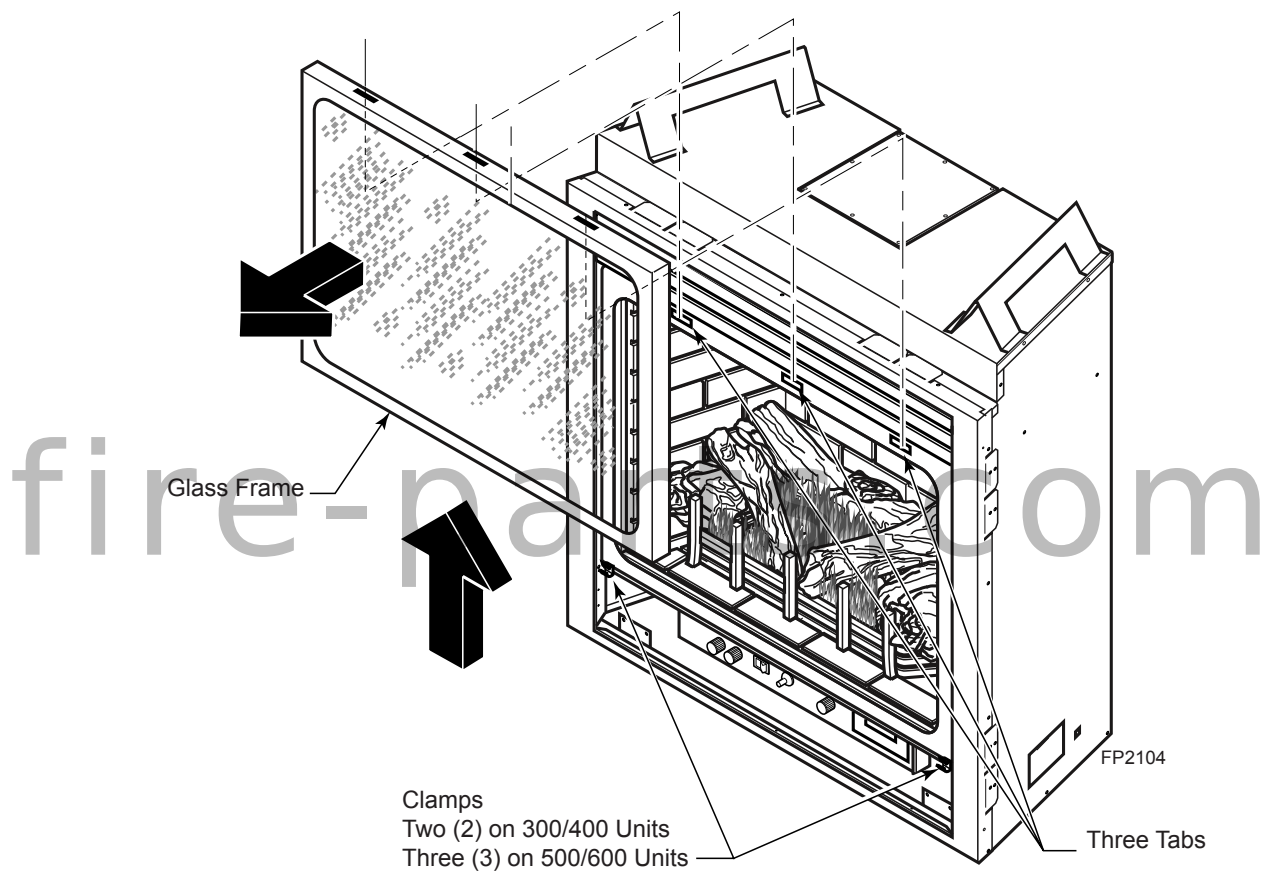

Figure 59 - Removing Glass Frame

CAUTION

Each clamp has a quick spring force. When reinstalling clamps, keep fingers clear. Remove control panel to operate middle clamp on 500 and 600 units.

ROCK WOOL PLACEMENT

1. Place rock wool on burner to provide glowing embers. For best results, pull the rock wool apart into pieces the size of a dime or smaller. **NOTE:** Embers must be loosely placed to allow proper burner flame.
2. Distribute one layer of rock wool to cover the burner. *Figure 60*
3. Place the logs on the burner. Refer to *Log Placement* below. Light unit and after 15 minutes, check burner flame and glow. Refer to *Burner Flame*, Page 49.

If the flame is blue and only in the center, turn off unit and let cool. After unit cools, remove logs. If the back holes are clear, add more rock wool to the center of the burner. Replace logs and check flame again. Save left over rock wool to refresh when cleaning later. Too much rock wool can disturb the flame and cause sooting on the glass or logs.

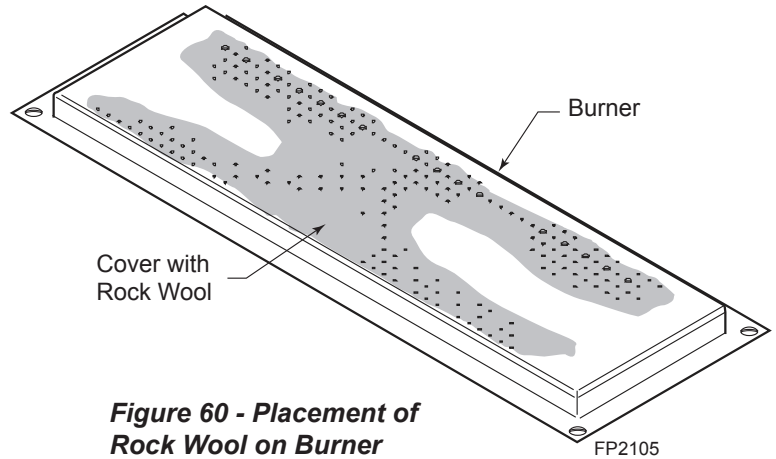

Figure 60 - Placement of Rock Wool on Burner

WARNING

Do not use the entire bag of rock wool to cover the burner. This could cause the flame to burn poorly and may lead to sooting.

LOG PLACEMENT

1. Place rear log (#1) on grate assembly. Log should rest firmly on the two log mounting pins on the bars. *Figure 61*
2. Place top right log (#2) on the rear log. Rest the right back side of the log in the flat area of the rear log. Place the narrow front end of the log next to the center vertical grate bar. *Figure 61*
3. Place the top left log (#3) on the rear log. Nest the forked end of the top left log into the fork or the rear log. Rest the narrow end of the top left log behind the center vertical grate bar. *Figure 61*

LAVA ROCK AND EMBER PLACEMENT

Sprinkle lava rock on the floor of the inner combustion chamber. Evenly distribute the rock. Do not pile the lava rock up in front of grate. Do not place lava rock on the burner. If desired, purchase optional embers to decorate the floor of the fireplace.

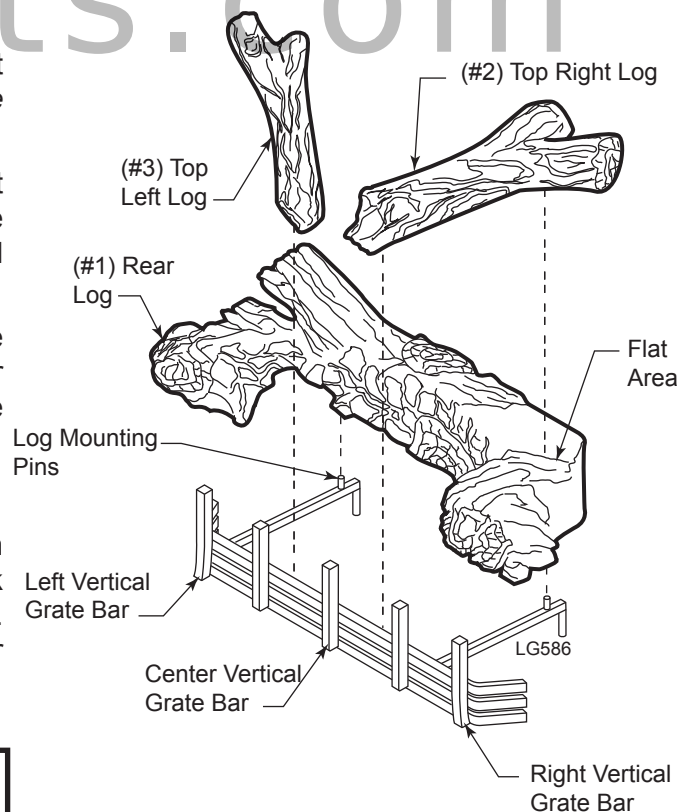

Figure 61 - Log Placement (BDV300, 400 shown)

WARNING

Do not sprinkle the lava rock or ember chunks on top of the burner. This may cause potential sooting, glass breakage and a fire hazard.

WARNING

Turn off gas before servicing fireplace. It is recommended that a qualified service technician perform these check-ups at the beginning of each heating season

BURNER, PILOT AND CONTROL COMPARTMENT

Keep the control compartment, logs, and burner areas surrounding the logs clean by vacuuming or brushing at least twice a year. Make sure the burner porting, pilot air opening and burner air opening are free of obstructions at all times.

PILOT FLAME

The flames from the pilot should be visually checked as soon as the heater is installed and periodically during normal operation. **The pilot flame must always be present when the fireplace is in operation.** *Figure 62.* The pilot flame has three distinct flames, one engulfing the thermopile, one engulfing the thermocouple, and the other reaching to the main burner..

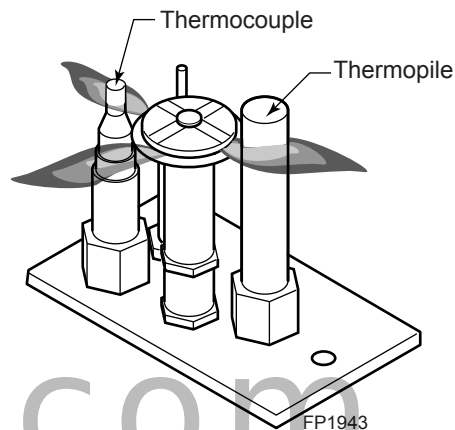

Figure 62 - Pilot Flame

BURNER

Inspect area around the injector. Remove any lint or foreign material with a brush or vacuum.

BURNER FLAME

The flames from the burner should be visually checked as soon as the heater is installed and periodically during normal operation. In normal operation, at full rate, and after operating for about 15 to 30 minutes, the flame should be yellow and slightly taller than the rear log. *Figure 63*

If the flame is blue and only in the center, turn off unit and let cool. After unit is cool, remove logs and check to make sure the back holes in the burner are not covered with rock wool. If the back holes are clear, add more rock wool to the center of the burner. Replace logs.

NOTE: *The type of installation, vent system configuration, and wind effects may cause the flame patterns to vary.*

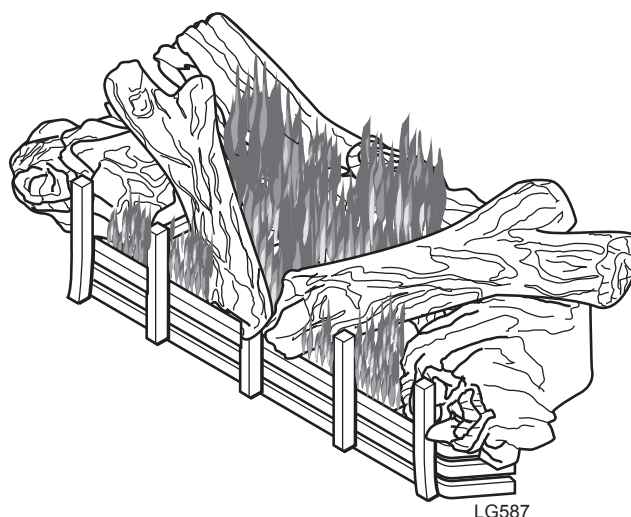

Figure 63 - Burner Flame Appearance

VENT SYSTEM

The fireplace and venting system should be inspected before initial use and at least annually by a qualified field service person. Inspect the external vent cap on a regular basis to make sure that no debris is interfering with the airflow. Inspect entire venting system to ensure proper function.

GLASS DOOR

Thoroughly clean the inside of the glass door after using the fireplace for ten hours. Periodically clean the glass door as necessary.

When cleaning the glass, remember:

- **Do not remove the glass when hot.** Allow glass to cool before removal.
- NEVER use abrasive materials.
- Keep children and pets a safe distance away.
- Never operate the fireplace without the glass door properly secured.
- Never operate the fireplace if the glass is broken.
- Replace any glass that is chipped, cracked, or broken. Replacement glass door assemblies **MUST** be supplied by the fireplace manufacturer – **No substitute materials may be used.**
- Handle glass door with care to avoid striking or scratching it on hard objects.

To clean glass door, follow “Glass Removal” procedure outlined in the *Final Installation* section. Film deposit on the inside of the glass should be cleaned off using a nontoxic, non-corrosive, non-abrasive, mild-cleaning solution. Simply apply an adequate amount to the glass and wipe off with a damp cloth. After all maintenance has been completed, re-install glass door.

LOGS

Leave logs installed in the fireplace for cleaning. Vacuum surface of the logs with a brush attachment. If logs must be removed for cleaning, handle carefully by holding gently at each end. Gloves are recommended to prevent skin irritation from ceramic fibers. If skin becomes irritated, wash gently with soap and water. Vacuum surface of logs with brush attachment or brush logs with a soft bristle brush (i.e. clean, dry paintbrush). To place logs back in the fireplace, see “Log Placement” found in the *Final Installation* section.

NOTE: Do not use fluids to clean ceramic fiber logs.

ROCK WOOL

Replace or add rock wool as required following installation instructions in the *Final Installation* section of this manual.

STANDING PILOT IGNITION

SYMPTOM	POSSIBLE CAUSE	ACTION
1. Spark ignitor will not light pilot after repeated triggering of piezo.	A. Wire disconnected.	A. Open door and check to make sure wire is connected to ignitor.
	B. Defective ignitor.	B. Check for spark at electrode and pilot. If no spark and electrode wire is properly connected, replace pilot assembly.
	C. No gas or low gas pressure.	C. Check remote/manual shut off valve from fireplace. Low pressure can be caused by bent lines, restricted lines, low pressure line pressure. Consult with plumber or gas supplier.
	D. No Propane/LPG in tank	D. Check Propane/LPG tank. Refill tank.
2. Pilot will not stay lit after carefully following lighting instructions.	A. Defective thermocouple	A. Check that thermocouple flame impinges on thermocouple. Clean and/or adjust pilot for maximum flame impingement. Ensure that the thermocouple connection at the gas valve is fully inserted and tight. Disconnect the thermocouple from the valve, place one millivolt lead wire on the tip of the thermocouple and the other meter lead wire on the thermocouple copper lead. Start the pilot and hold the valve knob in. If the millivolt reading is less than 15 mV, replace pilot assembly.
	B. Defective valve	B. If thermocouple is producing more than 15 mV, replace faulty valve.
3. Pilot burning, valve knob turned to "ON", switch is turned to "ON" or "RS", but burner will not ignite.	A. Defective switch, wall switch, remote control or wire	A. Check switch and wire for proper connection. Place jumper wires across terminals of switch. If burner comes on, replace defective switch. If the switch is OK, repeat the same procedure on remote control. If burner comes on, replace remote control. Place jumper wire across wire at gas valves (terminals marked TH and TP/TH). If burner comes on, wires are faulty or connections are bad. Replace wire.
	B. Pilot flame too small	B. If pilot flame is not close enough to the thermopile, adjust pilot flame.
	C. Defective or malfunctioning thermopile	C. Check thermopile wire connections to make sure all are tight and that the thermopile is fully inserted into pilot assembly. Check thermopile with a millivolt meter. Connect leads to TP and TP/TH terminals on the control valve. If meter reading is below 325 mV, replace pilot assembly.
	D. Defective valve	D. Turn valve knob to "On" and switch to "ON." Take a reading at the thermopile leads (TP & TP/TH) on the valve. If the meter reads greater than 175 mV and the burner does not light, replace defective valve.

STANDING PILOT IGNITION

SYMPTOM	POSSIBLE CAUSE	ACTION
4. Frequent pilot outage problem.	A. Pilot flame may be too high or too low, causing pilot safety to drop out	A. Clean and adjust the pilot flame for maximum flame impingement on thermocouple.
5. The pilot and main burner extinguish while in operation	A. Inner vent pipe leaking exhaust gases back into system B. Horizontal vent improperly pitched C. Improper vent cap installation	A. Check for flue product leak. Replace defective pipe section. B. Check horizontal-venting piping is running upward 1/4" per foot. Do not run the pipe level or downward. C. Check for proper installation and freedom from debris or blockage.
6. Glass Soots	A. Flame impingement on logs	A. Install log set per the instructions Inspect the injector and air intake area. Make sure this area does not have any blockage from debris and clean. Check gas supply.
7. Flame burn blue and lifts off burner (ghosting)	A. Insufficient oxygen being supplied	A. Ensure that the vent cap is installed properly and free of debris. Ensure that the vent system joints are tight and have no leaks. Ensure that no debris has been blocking the inner air intake at the bottom back of the combustion chamber. Ensure that the glass is properly secure and latch.

SIGNATURE COMMAND SYSTEM

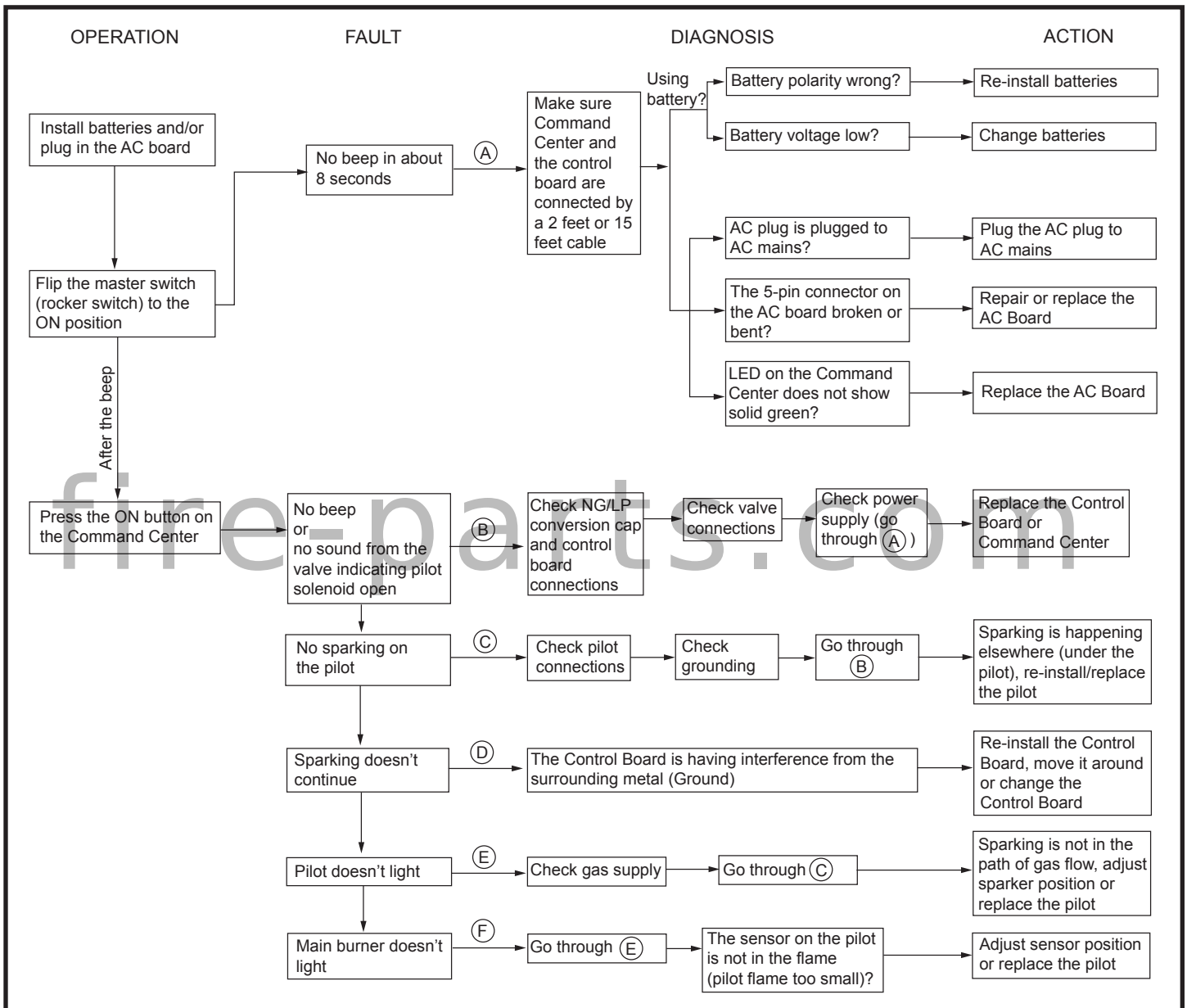

FIREBOX COMPONENTS

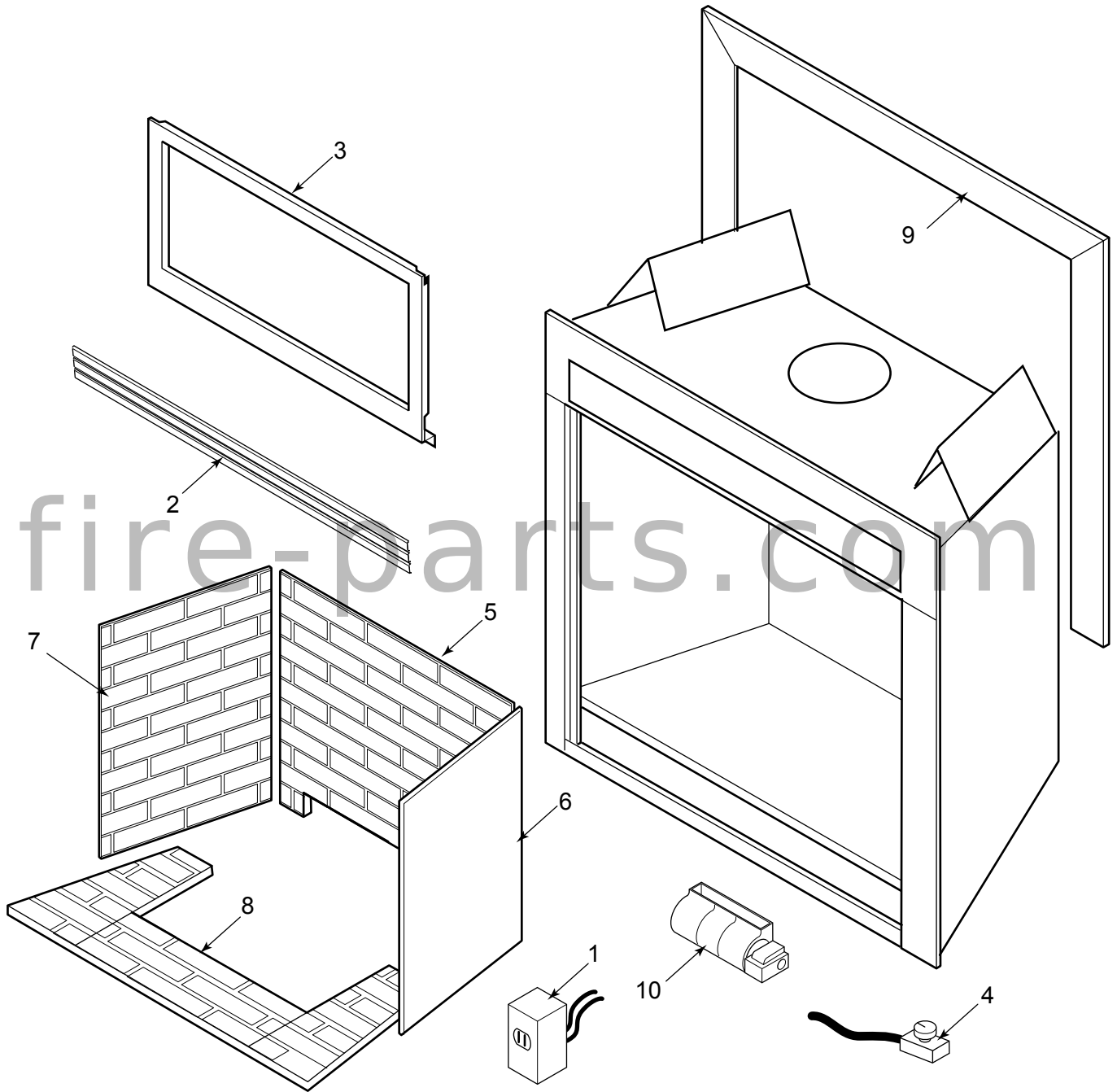

FIREBOX COMPONENTS

Item	Description	Qty.	BDV300	BDV400	BDV500	BDV600
Standard Features						
1.	Junction Box	1	26D2128K	26D2128K	26D2128K	26D2128K
2.	Black Louver	6	54D0246	26D0695	26D0697	26D0699
3.	Glass Frame Assembly	1	54D0294	54D0340	54D0195	54D0443
Factory Installed Options						
2.	Brass Louver	6	54D0249K	26D0701K	26D0703K	26D0705K
4.	Speed Control	1	26D0746	26D0746	26D0746	26D0746
5.	Standard Firebrick Center CC	1	26D7069	267077	26D7083	26D7089
6.	Standard Firebrick Right CC	1	26D7068	26D7076	26D7076	26D7076
7.	Standard Firebrick Left CC	1	26D7068	26D7075	26D7075	26D7075
5.	Standard Firebrick Center CR	1	26D7097	26D7105	26D7111	26D7117
6.	Standard Firebrick Right CR	1	26D7096	26D7104	26D7104	26D7104
7.	Standard Firebrick Left Cr	1	26D7096	26D7103	26D7103	26D7103
10.	Blower Motor	1	54D0281	26D0748	26D0748	26D0748
Accessories / Field Installed Options						
2.	Brass Louver	1	L30BR	L32BR	L36BR	L42BR
2.	Pewter Louver	1	L30PW	L32PW	L36PW	L42PW
5,6,7	Firebrick Walls CC	1	FB300CCW	FB400CCW	FB400CCW	FB600CCW
8.	Firebrick Floor CC	1	FB300CCF	FB400CCF	FB500CCF	FB600CCF
5,6,7	Firebrick Walls CR	1	FB300CRW	FB400CRW	FB500CRW	FB600CRW
8.	Firebrick Floor CR	1	FB300CRF	FB400CRF	FB500CRF	FB600CRF
9.	Curved Design - Brass	1	BRTK30C	BRTK32C	BRTK36C	BRTK42C
9.	Curved Design - Pewter	1	PWTK30C	PWTK32C	PWTK36C	PWTK42C
9.	Curved Design - black	1	BLTK30C	BLTK32C	BLTK36C	BLTK42C
9.	Black Trim	1	BLMTK30	BLMTK32	BLMTK36	BLMTK42C
9.	Pewter Trim	1	PWMTK30	PWMTK32	PWMTK36	PWMTK42
9.	Brass Trim	1	BRMTK30	BRMTK32	BRMTK36	BRMTK42
10.	T-Stat Blower w/ Speed Control	1	BLOTS	BLOTS	BLOTS	BLOTS
10.	Blower w/ Time Delay	1	BLOTSC	BLOTSC	BLOTSC	BLOTSC

CC=Cottage Clay

CR=Cottage Red

STANDING PILOT — MILLIVOLT CONTROL

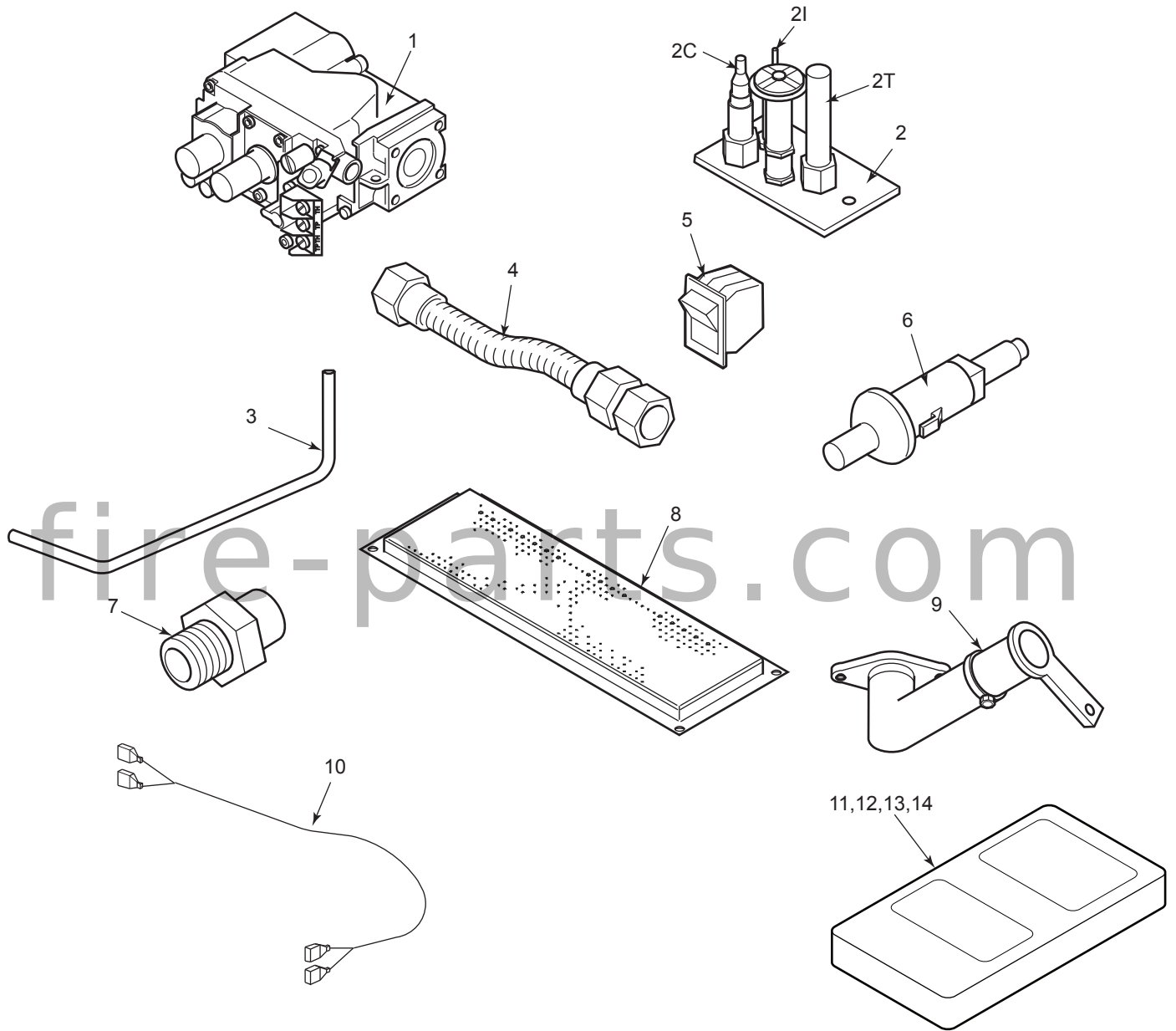

STANDING PILOT – MILLIVOLT CONTROL

Item	Description	Qty.	BDV300NV	BDV300PV	BDV400NV	BDV400PV	BDV500NV	BDV500PV	BDV600NV	BDV600PV
1.	Gas Valve Assy.	1	37D0117	37D0118	37D0117	37D0118	37D0117	37D0118	37D0117	37D0118
2.	Pilot Assembly	1	37D0018	37D0019	37D0018	37D0019	37D0018	37D0019	37D0018	37D0019
2C.	Replacement Thermocouple	1	37D1067	37D1067	37D1067	37D1067	37D1067	37D1067	37D1067	37D1067
2I.	Replacement Igniter and Wire	1	37D1069	37D1069	37D1069	37D1069	37D1069	37D1069	37D1069	37D1069
2T.	Replacement Thermopile	1	37D1068	37D1068	37D1068	37D1068	37D1068	37D1068	37D1068	37D1068
3.	Burner Tube	1	54D0288	54D0288	54D0194	54D0194	54D0194	54D0194	54D0194	54D0194
4.	Flexhose with Shutoff Valve	1	23D6046	23D6046	23D6046	23D6046	23D6046	23D6046	23D6046	23D6046
5.	Rocker Switch	1	41D0048	41D0048	41D0048	41D0048	41D0048	41D0048	41D0048	41D0048
6.	Piezo Igniter	1	14D0503	14D0503	14D0503	14D0503	14D0503	14D0503	14D0503	14D0503
7.	Injector	1	62D3006	20H3146	62D3004	20H3143	20H3145	57D0210	20H3145	57D0210
8.	Burner Assembly	1	54D0200	54D0200	54D0001	54D0001	54D0329	54D0329	54D0329	54D0329
9.	Venturi	1	45D0600	45D0600	45D0600	45D0600	45D0600	45D0600	45D0600	45D0600
10.	Wire Assembly	1	44D0500	44D0500	44D0500	44D0500	44D0500	44D0500	44D0500	44D0500
10.	Wire Assembly	1	44D0501	44D0501	44D0501	44D0501	44D0501	44D0501	44D0501	44D0501

Accessories

11.	Thermostatic Remote Control	1	RCST, RCT, RCSTE, RCSTEB, RCSIT, RCSITE, WWTD							
12.	Remote Control On/Off	1	RCB, RCMT, RCBE, WMTD							
13.	Wall Switch Kit	1	MVWS							
14.	Wall Thermostat Kit	1	WT							

Conversion Kit (not shown) Millivolt & Electronic

300 Conversion NG to LPG	1	BCK300CKPA	--	--	--	--	--	--	--
300 Conversion LPG to NG	1	--	BCK300CKNA	--	--	--	--	--	--
400 Conversion NG to LPG	1	--	--	BCK400CKPA	--	--	--	--	--
400 Conversion LPG to NG	1	--	--	--	BCK400CKNA	--	--	--	--
500 Conversion NG to LPG	1	--	--	--	--	BCK500CKPA	--	--	--
500 Conversion LPG to NG	1	--	--	--	--	--	BCK500CKNA	--	--
600 Conversion NG to LPG	1	--	--	--	--	--	--	BCK600CKPA	--
600 Conversion LPG to NG	1	--	--	--	--	--	--	--	BCK600CKNA

ELECTRONIC IGNITION

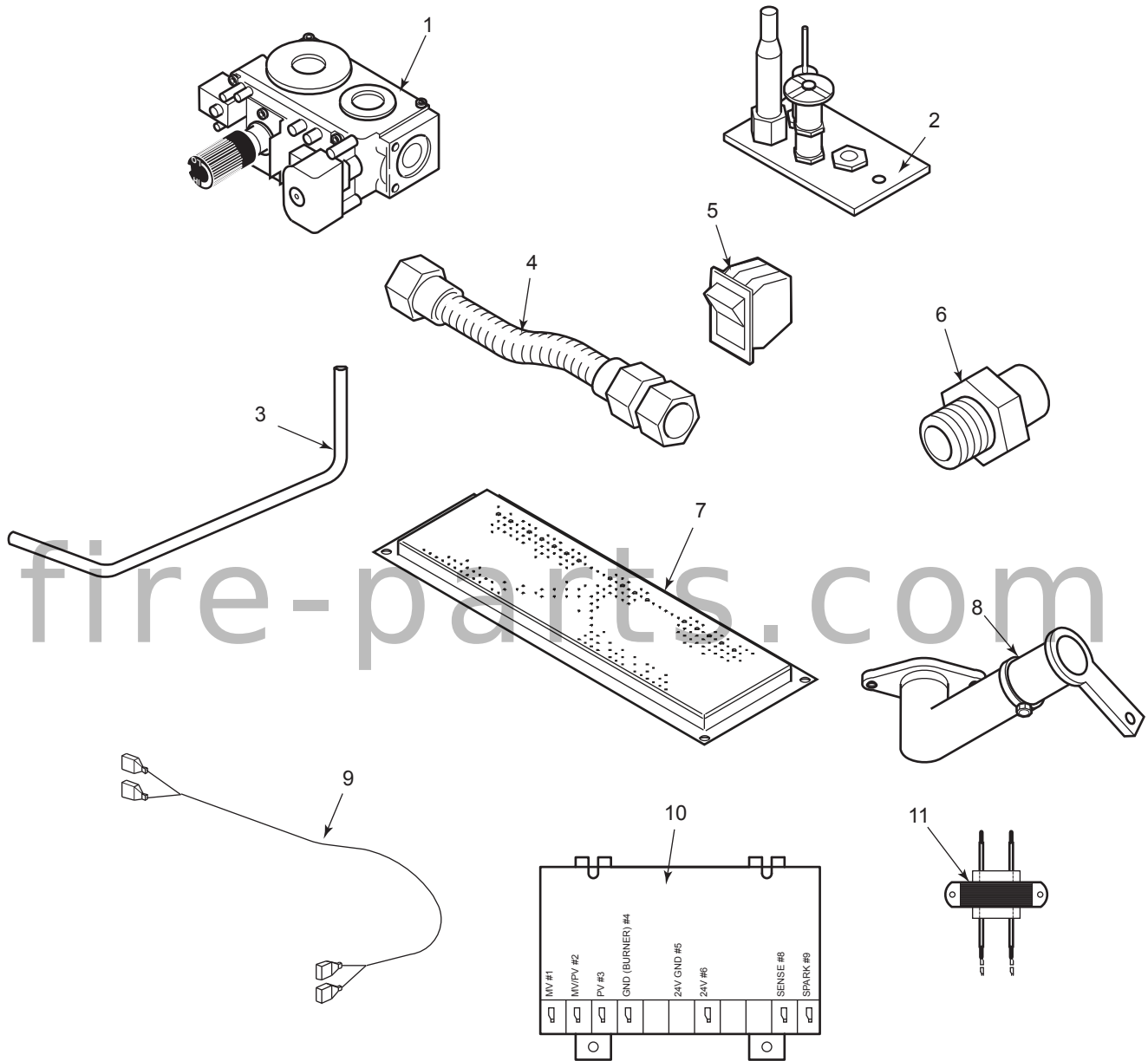

ELECTRONIC IGNITION

Item	Description	Qty.	BDV300NE	BDV300PE	BDV400NE	BDV400PE	BDV500NE	BDV500PE	BDV600NE	BDV600PE
1.	Gas Valve Assy.	1	37D0016	37D0017	37D0016	37D0017	37D0016	37D0017	37D0016	37D0017
2.	Pilot Assembly	1	37D0020	37D0021	37D0020	37D0021	37D0020	37D0021	37D0020	37D0021
3.	Burner Tube	1	54D0288	54D0288	54D0194	54D0194	54D0194	54D0194	54D0194	54D0194
4.	Flexhose with Shutoff Valve	1	23D6046	23D6046	23D6046	23D6046	23D6046	23D6046	23D6046	23D6046
5.	Rocker Switch	1	41D0048	41D0048	41D0048	41D0048	41D0048	41D0048	41D0048	41D0048
6.	Injector	1	62D3006	20H3146	62D3004	20H3143	20H3145	57D0210	20H3145	57D0210
7.	Burner Assembly	1	54D0200	54D0200	54D0001	54D0001	54D0329	54D0329	54D0329	54D0329
8.	Venturi	1	45D0600	45D0600	45D0600	45D0600	45D0600	45D0600	45D0600	45D0600
9.	Wire Assembly	1	54D2001	54D2001	54D2001	54D2001	54D2001	54D2001	54D2001	54D2001
10.	Ignition Module	1	37D0325	37D0325	37D0325	37D0325	37D0325	37D0325	37D0325	37D0325
11.	Transformer	1	37D0027	37D0027	37D0027	37D0027	37D0027	37D0027	37D0027	37D0027

fire-parts.com

SIGNATURE COMMAND SYSTEM

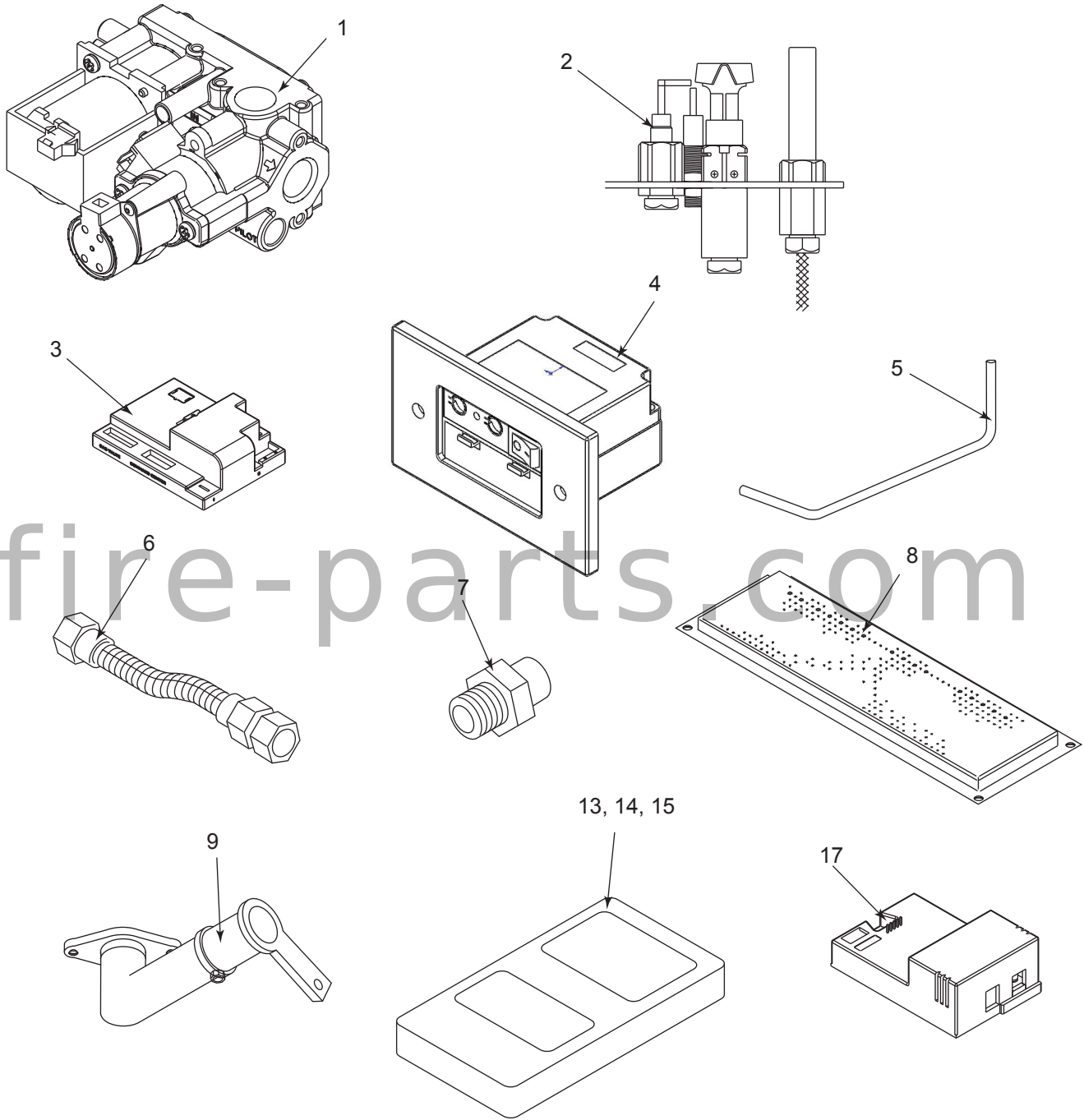

SIGNATURE COMMAND SYSTEM

Item	Description	Qty.	BDV300NS	BDV300PS	BDV400NS	BDV400PS	BDV500NS	BDV500PS	BDV600NS	BDV600PS
1.	Gas Valve Assy.	1	80D0001	80D0002	80D0001	80D0002	80D0001	80D0002	80D0001	80D0002
2.	Pilot Assembly	1	80D0006	80D0007	80D0006	80D0007	80D0006	80D0007	80D0006	80D0007
3.	Control Box	1	80D0018	80D0019	80D0018	80D0019	80D0018	80D0019	80D0018	80D0019
4.	Command Center	1	80D0005	80D0005	80D0005	80D0005	80D0005	80D0005	80D0005	80D0005
5.	Burner Tube	1	54D6004	54D6004	54D6004	54D6004	54D6004	54D6004	54D6004	54D6004
6.	Flexhose with Shutoff Valve	1	69D0030	69D0030	69D0030	69D0030	69D0030	69D0030	69D0030	69D0030
7.	Injector	1	62D3006	20H3146	62D3004	20H3143	20H3145	57D0210	20H3145	57D0210
8.	Burner Assembly	1	54D0200	54D0200	54D0001	54D0001	54D0329	54D0329	54D0329	54D0329
9.	Venturi	1	45D0600	45D0600	45D0600	45D0600	45D0600	45D0600	45D0600	45D0600
10.	Wire Valve Control (not shown)	1	80D0010	80D0010	80D0010	80D0010	80D0010	80D0010	80D0010	80D0010
11.	Wire Command Ctr Control Box 2' (not shown)	1	80D0008	80D0008	80D0008	80D0008	80D0008	80D0008	80D0008	80D0008
Accessories										
13.	Hand Held Remote Control w/ HI/LO & Timer	1		RMSC		RMSC		RMSC		RMSC
14.	Hand Held Remote Control w/HI/LO & Tstat	1		RTSC		RTSC		RTSC		RTSC
15.	Hand Held Remote Control w/Optional Light, Auxiliary and Blower Control	1		RFSC		RFSC		RFSC		RFSC
16.	SCS Wall Mount Extension Kit (15' wire, rough-in box, wall cover) (not shown)	1		SCSWEK		SCSWEK		SCSWEK		SCSWEK
17.	SCS AC Module (converted battery system to AC power)	1		SCSACM		SCSACM		SCSACM		SCSACM
18.	Forged Andiron 8 ³ / ₄ (not shown)	1		FAI83/4		FAI83/4		FAI83/4		FAI83/4
19.	Mesh Glass Cover (not shown)	1		BDV300SD		BDV400SD		BDV500SD		BDV600SD
Gas Conversion Kit (not shown)										
20.	NG to LP	1	BCK300CKPS	--	BCK400CKPS	--	BCK500CKPS	--	BCK600CKPS	--
21.	LP to NG	1	--	BCK300CKNS	--	BCK400CKNS	--	BCK500CKNS	--	BCK600CKNS

VENT COMPONENTS

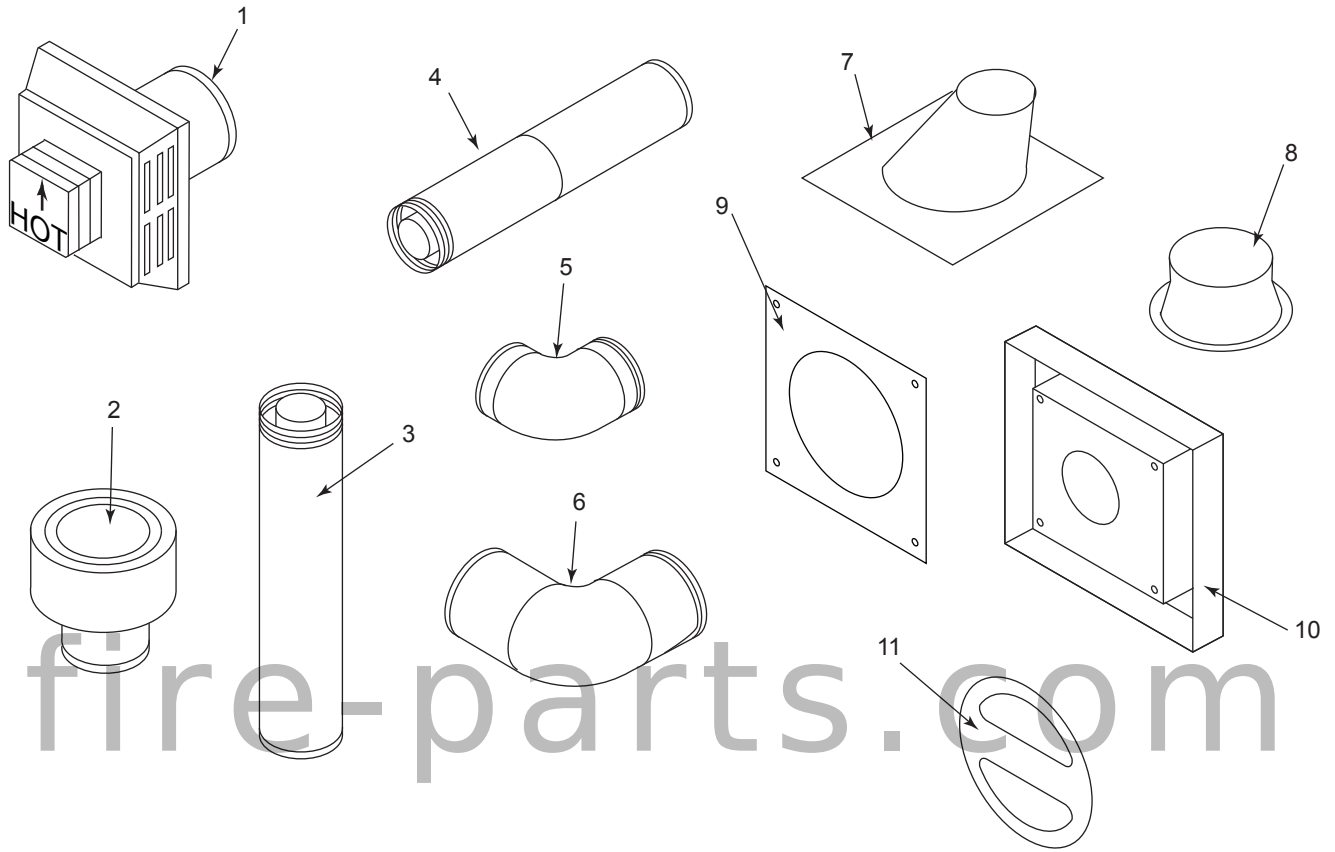

ILLUSTRATED PARTS LIST

BDV Series Gas Fireplace

VENT COMPONENTS

Item	Qty./ Box	Description	Current Simpson Duravent or MHSC Part no.	Old Simpson Duravent or MHSC Part no.	Selkirk Part no.
1	1	Side Wall Flexible Pipe Termination Kit Includes termination cap with built-in vinyl siding standoff, heat deflector, firestop, 20" to 48" flexible pipe and adapter.	BHSFTKA	BHSFTK	--
1	1	Horizontal Pipe Termination Kit with Horizontal Termination Cap with built-in vinyl siding standoff, heat deflector, firestop, 11" x 14 ^{5/8} " adjustable pipe and 90° Elbow	BHSTK	BHSTK	--
1	1	Thru-roof Flexible Pipe Termination Kit with flex adapter 24" rigid pipe, roof support 4" x 6 ^{5/8} " and termination cap	TRFK	--	--
1	1	Horizontal Square Termination Cap with built-in vinyl siding standoff, heat deflector and firestop	BHRTK	BHRTK	--
1	1	Square Horizontal Termination Cap	46DVA-HC	985	4DT-HC
1	1	Round Horizontal Termination Cap	46DVS-HRCS	--	--
1	1	Sconce Termination Cap (aluminum)	46DVA-HSC	--	--
2	1	Low-Profile Vertical Termination Cap	46DVA-VC	980	4DT-VC
3	6	6" Pipe Length (galvanized)	46DVA-06	908	4DT-06
3	6	9" Pipe Length (galvanized)	46DVA-09	907	4DT-09
3	6	12" Pipe Length (galvanized)	46DVA-12	906	4DT-1
3	6	24" Pipe Length (galvanized)	46DVA-24	904	4DT-4
3	6	36" Pipe Length (galvanized)	46DVA-36	903	4DT-36
3	6	48" Pipe Length (galvanized)	46DVA-48	902	4DT-48
4	6	8 ^{1/2} " Pipe Extension (galvanized)	46DVA-08A	--	4DT-AJ
4	6	16" Pipe Extension (galvanized)	46DVA-16A	--	4DT-AJ14
5	6	45° Elbow (galvanized)	46DVA-E45	945	4DT-EL45
6	6	90° Elbow (galvanized)	46DVA-E90	990	4DT-EL90
7	6	Adjustable Roof Flashing 0/12 - 6/12	46DVA-F6	943	4DT-AF6
8	6	Storm Collar	46DVA-SC	953	4DT-SC
9	6	1" Firestop	46DVA-FS	963	4DT-FS
9	6	3" Firestop	FS3	--	--
10	1	Vinyl Siding Standoff	46DVA-VSS	950	4DT-VS
11	1	Restrictor Disk	45D0551	45D0551	--
	1	Attic Insulation Shield	46DVA-IS	--	--
	6	Steep Roof Flashing 7/12 - 12/12	46DVA-F12	943S	--
	8	Horizontal Termination with 1" firestop	BHRT/8	--	--
	8	Flex Adapter Starter	DVFA/8	--	--

For more information about, or instructions for, the venting components referenced above, please contact the component manufacturer:

Selkirk Corporation: www.selkirkcorp.com or 800-992-8368

Simpson Duravent: www.duravent.com or 800-835-4429

LOGS

Item	Description	Qty.	BDV300	BDV400	BDV500	BDV600
1.	Rear Log	1	54D0121	54D0181	54D0339	54D0339
2.	Right Log	1	54D0147	54D0116	54D0361	54D0361
3.	Left Log	1	54D0146	54D0115	54D0360	54D0360

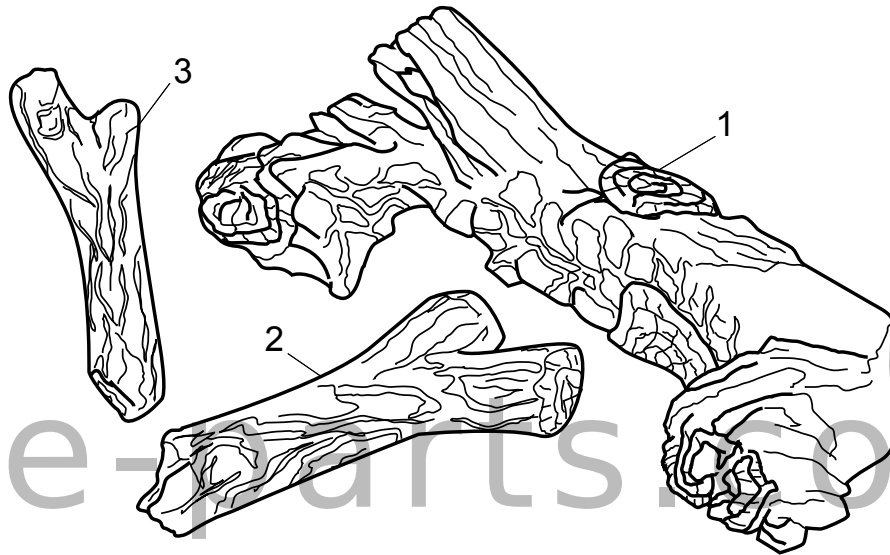

fire-parts.com

MASSACHUSETTS RESIDENTS ONLY: PLEASE READ AND FOLLOW THESE SPECIAL REQUIREMENTS

NOTE REGARDING VENTED PRODUCTS

This product must be installed by a licensed plumber or gas fitter when installed within the Commonwealth of Massachusetts.

Any residence with a direct vent product must have a CO detector installed in the residence.

Installation of the fireplace or vented gas log in the State of Massachusetts requires the damper to be permanently removed or welded in the fully open position.

In addition, a naturally vented gas log may not be installed in a bedroom or bathroom in the State of Massachusetts.

Flex line installation must not exceed 36 inches and must have a T shutoff valve.

NOTE REGARDING VENT FREE PRODUCTS

This product must be installed by a licensed plumber or gas fitter when installed within the Commonwealth of Massachusetts.

In addition, vent free products may not be installed in a bedroom or bathroom regardless of size or type in the State of Massachusetts.

Flex line installation must not exceed 36 inches and must have a T shutoff valve.

CARBON MONOXIDE DETECTOR REQUIREMENTS

(2) Revise 10.8.3 by adding the following additional requirements:

- (a) For all side wall horizontally vented gas fueled equipment installed in every dwelling, building or structure used in whole or in part for residential purposes, including those owned or operated by the Commonwealth and where the side wall exhaust vent termination is less than seven (7) feet above finished grade in the area of the venting, including but not limited to decks and porches, the following requirements shall be satisfied:
1. **INSTALLATION OF CARBON MONOXIDE DETECTORS.** At the time of installation of the side wall horizontal vented gas fueled equipment, the installing plumber or gasfitter shall observe that a hard wired carbon monoxide detector with an alarm and battery back-up is installed on the floor level where the gas equipment is to be installed. In addition, the installing plumber or gasfitter shall observe that a battery operated or hard wired carbon monoxide detector with an alarm is installed on each additional level of the dwelling, building or structure served by the side wall horizontal vented gas fueled equipment. It shall be the responsibility of the property owner to secure the services of qualified licensed professionals for the installation of hard wired carbon monoxide detectors
 - a. In the event that the side wall horizontally vented gas fueled equipment is installed in a crawl space or an attic, the hard wired carbon monoxide detector with alarm and battery back-up may be installed on the next adjacent floor level.
 - b. In the event that the requirements of this subdivision can not be met at the time of completion of installation, the owner shall have a period of thirty (30) days to comply with the above requirements; provided, however, that during said thirty (30) day period, a battery operated carbon monoxide detector with an alarm shall be installed.

SPECIAL REQUIREMENTS CONTINUED

2. APPROVED CARBON MONOXIDE DETECTORS. Each carbon monoxide detector as required in accordance with the above provisions shall comply with NFPA 720 and be ANSI/UL 2034 listed and IAS certified.
 3. SIGNAGE. A metal or plastic identification plate shall be permanently mounted to the exterior of the building at a minimum height of eight (8) feet above grade directly in line with the exhaust vent terminal for the horizontally vented gas fueled heating appliance or equipment. The sign shall read, in print size no less than one-half (1/2) inch in size, "**GAS VENT DIRECTLY BELOW. KEEP CLEAR OF ALL OBSTRUCTIONS.**"
 4. INSPECTION. The state or local gas inspector of the side wall horizontally vented gas fueled equipment shall not approve the installation unless, upon inspection, the inspector observes carbon monoxide detectors and signage installed in accordance with the provisions of 248 CMR 5.08(2)(a)1 through 4.
- (b) EXEMPTIONS: The following equipment is exempt from 248 CMR 5.08(2)(a)1 through 4:
1. The equipment listed in Chapter 10 entitled "Equipment Not Required To Be Vented" in the most current edition of NFPA 54 as adopted by the Board; and
 2. Product Approved side wall horizontally vented gas fueled equipment installed in a room or structure separate from the dwelling, building or structure used in whole or in part for residential purposes.
- (c) MANUFACTURER REQUIREMENTS - GAS EQUIPMENT VENTING SYSTEM PROVIDED. When the manufacturer of Product Approved side wall horizontally vented gas equipment provides a venting system design or venting system components with the equipment, the instructions provided by the manufacturer for installation of the equipment and the venting system shall include:
1. Detailed instructions for the installation of the venting system design or the venting system components; and
 2. A complete parts list for the venting system design or venting system.
- (d) MANUFACTURER REQUIREMENTS - GAS EQUIPMENT VENTING SYSTEM NOT PROVIDED. When the manufacturer of a Product Approved side wall horizontally vented gas fueled equipment does not provide the parts for venting the flue gases, but identifies "special venting systems," the following requirements shall be satisfied by the manufacturer:
1. The identification of each "special venting system" shall include either the listing of the website, phone number or manufacturer's address where the venting system installation instructions can be obtained; and
 2. The "special venting systems" shall be Product Approved by the Board, and the instructions provided with that system shall include a parts list and detailed installation instructions.
- (e) A copy of all installation instructions for the Product Approved side wall horizontally vented gas fueled equipment and all the venting instructions, parts lists, and/or all design instructions for the venting system shall remain with the appliance or equipment at the completion of the installation.

LIMITED LIFETIME WARRANTY POLICY

LIFETIME WARRANTY

The following components are warranted for life to the original owner, subject to proof of purchase: Firebox, Combustion Chamber, Heat Exchanger, Grate and Stainless Steel Burners.

FIVE YEAR WARRANTY

The following components are warranted five (5) years to the original owner, subject of proof of purchase: Ceramic Fiber Logs.

BASIC WARRANTY

MHSC warrants the components and materials in your gas appliance to be free from manufacturing and material defects for a period of two years from date of installation. After installation, if any of the components manufactured by MHSC in the appliance are found to be defective in materials or workmanship, MHSC will, at its option, replace or repair the defective components at no charge to the original owner. MHSC will also pay for reasonable labor costs incurred in replacing or repairing such components for a period of two years from date of installation. Any products presented for warranty repair must be accompanied by a dated proof of purchase.

This Limited Lifetime Warranty will be void if the appliance is not installed by a qualified installer in accordance with the installation instructions. The Limited Lifetime Warranty will also be void if the appliance is not operated and maintained according to the operating instructions supplied with the appliance, and does not extend to (1) firebox/burner assembly damage by accident, neglect, misuse, abuse, alterations, negligence of others, including the installation thereof by unqualified installers, (2) the costs of removal, reinstallation or transportation of defective parts on the appliance, or (3) incidental or consequential damage. All service work must be performed by an authorized service representative.

This warranty is expressly in lieu of other warranties, express or implied, including the warranty of merchantability of fitness for purpose and of all other obligations or liabilities. MHSC does not assume for it any other obligations or liabilities in connection with sale or use of the appliance. It states that do not allow limitations on how long an implied warranty lasts, or do not allow exclusion of indirect damage, those limitations of exclusions may not apply to you. You may also have additional rights not covered in the Limited Lifetime Warranty.

MHSC reserves the right to investigate any and all the claims against the Limited Lifetime Warranty and decide upon method of settlement.

IF WARRANTY SERVICE IS NEEDED...

1. Contact your supplier. Make sure you have your warranty, your sales receipt and the model/serial number of your MHSC product.
2. DO NOT ATTEMPT TO DO ANY SERVICE WORK YOURSELF.

Canada

ENERGUIDE

**Look for the EnerGuide
Gas Fireplace Energy
Efficiency Rating in this brochure**

Based on CSA P.4.1-02

Efficiency Ratings	
Model	EnerGuide Ratings Fireplace Efficiency (%)
BDV300NV	57.9
BDV300PV	53.8
BDV300NE	61.8
BDV300PE	55.7
BDV400NV	58.4
BDV400PV	58.5
BDV400NE	61.1
BDV400PE	60/7
BDV500NV	58.7
BDV500PV	58.8
BDV500NE	61.3
BDV500PE	60/8
BDV600NV	58.4
BDV600PV	58.5
BDV600NE	60.9
BDV600PE	60.5

MHSC

149 Cleveland Drive • Paris, Kentucky 40361
www.mhsc.com