



# SERVICE PARTS LIST

**BULLETIN NO.**  
**55-26-2480**

SPECIFY CATALOG NO. AND SERIAL NO. WHEN ORDERING PARTS		REVISED BULLETIN	DATE
<b>M12 Brushless 1/4" Hex Impact Driver</b>			Jan. 2013
CATALOG NO.	<b>2453-059</b>	STARTING SERIAL NO.	<b>F13A</b>
		WIRING INSTRUCTION <b>SEE PAGE 2</b>	

**IMPORTANT NOTE: Gearcase end cap #25 is LEFT HAND THREAD!**

As an aid to assembly, carefully lower the complete front end of tool (gearcase/impacting system) onto the gearcase end cap. Gently hand tighten front end assembly onto gearcase end cap. Be careful not to cross-thread! Once installed by hand, seat gearcase end cap with a 9/16" open end wrench using light pressure. Do not over tighten!

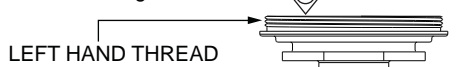

LEFT HAND THREAD

**Torque to 260 in/lbs ±24 in/lbs  
(300 kgf-cm ±27 kgf-cm)**

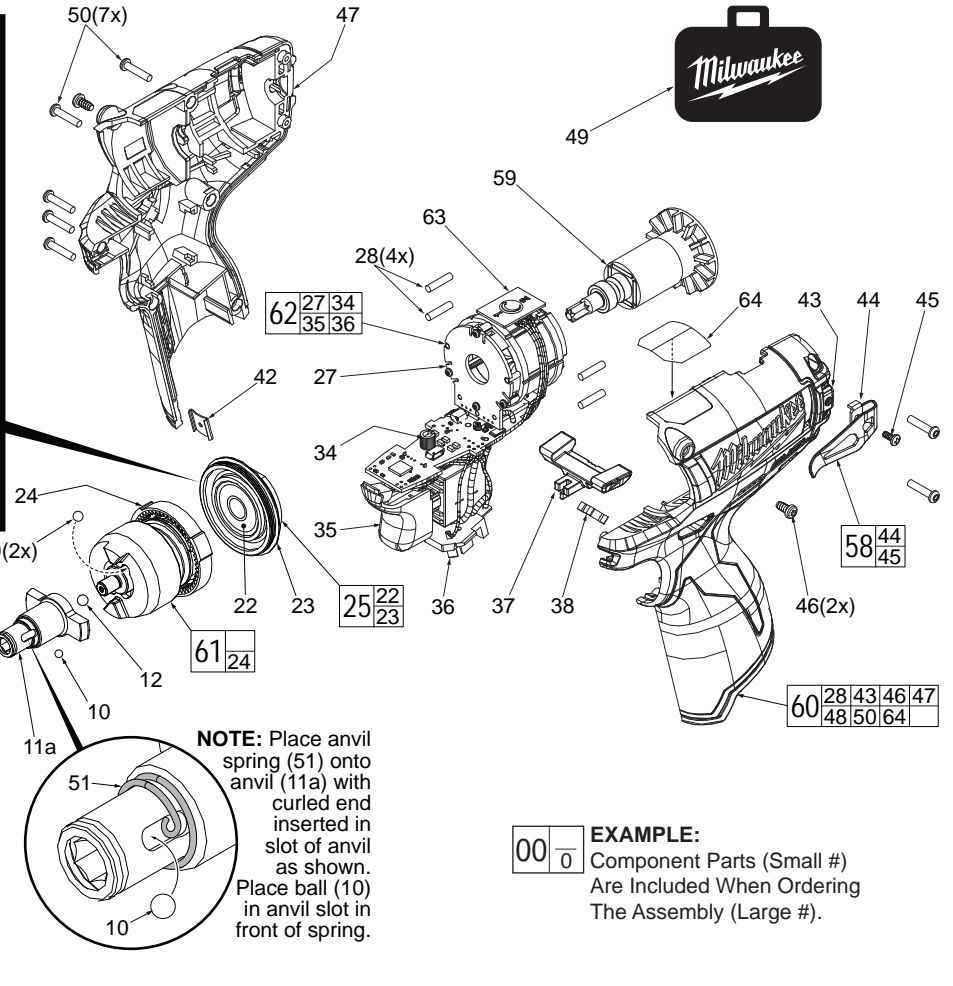

**NOTE:** Place anvil spring (51) onto anvil (11a) with curled end inserted in slot of anvil as shown. Place ball (10) in anvil slot in front of spring.

**EXAMPLE:**  
Component Parts (Small #)  
Are Included When Ordering  
The Assembly (Large #).

FIG.	PART NO.	DESCRIPTION OF PART	NO. REQ.
1	31-12-0575	Rubber Cap	(1)
2	45-22-2653	Sleeve	(1)
3	34-60-0725	Retaining Ring	(1)
4	45-88-1880	Washer	(1)
5	40-50-1470	Spring	(1)
6	-----	Anvil Bushing (Not Shown)	(1)
9	45-88-2135	Plastic Washer	(1)
10	02-02-0170	3.5mm Steel Ball	(1)
11a	42-06-0720	1/4" Hex Anvil	(1)
12	02-02-1300	5mm Steel Ball	(1)
19	02-02-0180	4.7mm Steel Ball	(2)
22	-----	Ball Bearing	(1)
23	-----	Gearcase End Cap	(1)
24	-----	Ring Gear	(1)
25	44-66-1065	Gearcase End Cap Assembly	(1)
27	-----	Stator Assembly	(1)
28	45-30-0300	Rubber Slug	(4)
34	-----	PCBA	(1)
35	-----	On-Off Switch	(1)
36	-----	Terminal Block Assembly	(1)
37	45-24-0810	Fwd/Rev Shuttle	(1)
38	40-50-1135	Spring	(1)
42	42-70-0055	Housing Clip	(1)
43	-----	Left Handle Halve with Fuel Gauge	(1)
44	42-70-0580	Belt Clip	(1)
45	-----	Belt Hook Screw	(1)
46	06-82-1090	M3 x 7mm Pan Hd. Plastite Screw	(2)

FIG.	PART NO.	DESCRIPTION OF PART	NO. REQ.
47	-----	Right Handle Halve	(1)
48	-----	Service Nameplate (Not Shown)	(1)
49	42-55-1060	Carrying Case	(1)
50	06-82-7236	4-20 x 5/8" Pan Hd. Plastite T-10 Scr	(7)
51	40-50-0012	Anvil Spring	(1)
56	14-30-1170	Gearcase Assembly	(1)
57	28-50-0920	Front Gearcase with Bushing	(1)
58	42-70-0490	Belt Clip Assembly	(1)
59	16-07-0420	Rotor Assembly	(1)
60	31-44-2453	Handle Assembly	(1)
61	14-30-1200	Impacting Assembly	(1)
62	14-20-1520	Electronics Assembly	(1)
63	23-66-2455	POP Switch	(1)
64	10-20-2845	Spanish/French Warning Label	(1)

- FIG. LUBRICATION (Type 'J' Grease, No. 49-08-4220):**
- 10,11a Lightly coat front washer surface of anvil (11a) with grease, place a dab in the ball slot of anvil.
  - 24,61 Lightly coat the I.D. of the ring gear (24) and the center of the planet gears of impacting assembly with grease.
  - 57 Coat inside of bushing inside front gearcase with grease.
  - 59 Coat pinion of rotor assembly (59) with grease.

**AS AN AID TO REASSEMBLY, TAKE NOTICE OF WIRE ROUTING AND POSITION IN WIRE GUIDES AND TRAPS WHILE DISMANTLING TOOL.**

**BE CAREFUL AND AVOID PINCHING WIRES BETWEEN HANDLE HALVES WHEN ASSEMBLING.**

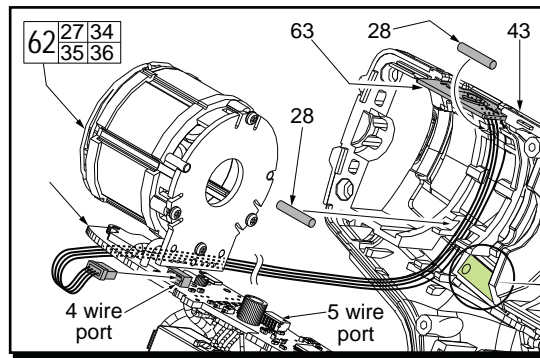

The fuel gauge assembly is a fixed component of the left handle halve (43). Connect the five wire terminal block to the corresponding five wire port on the PCBA.

Place POP Switch (63) into top slot of left handle halve. Be sure that the '2' is positioned to the back of tool. Route the four wires through the channel along the inside wall as shown. Trap the wires in place using two Rubber Slugs (28). Carefully place all components of the Electronics Assembly (62) into the handle halve. Connect the four wire terminal to the port on PCBA (34).

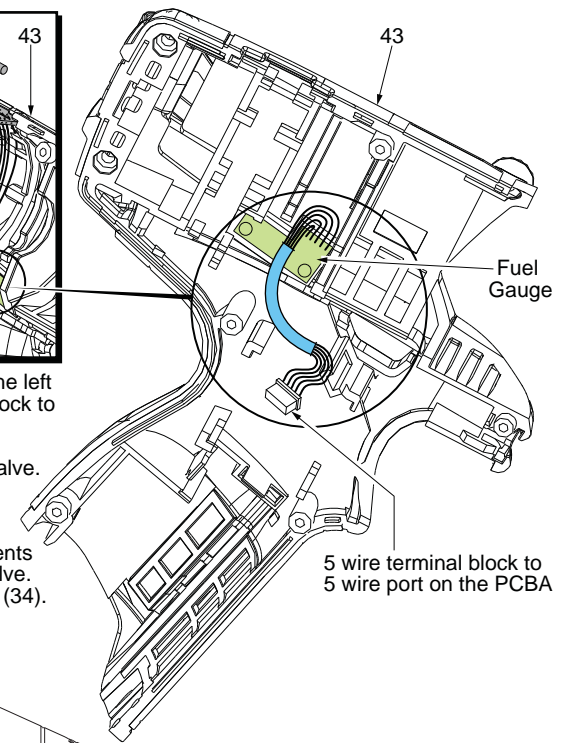

5 wire terminal block to 5 wire port on the PCBA

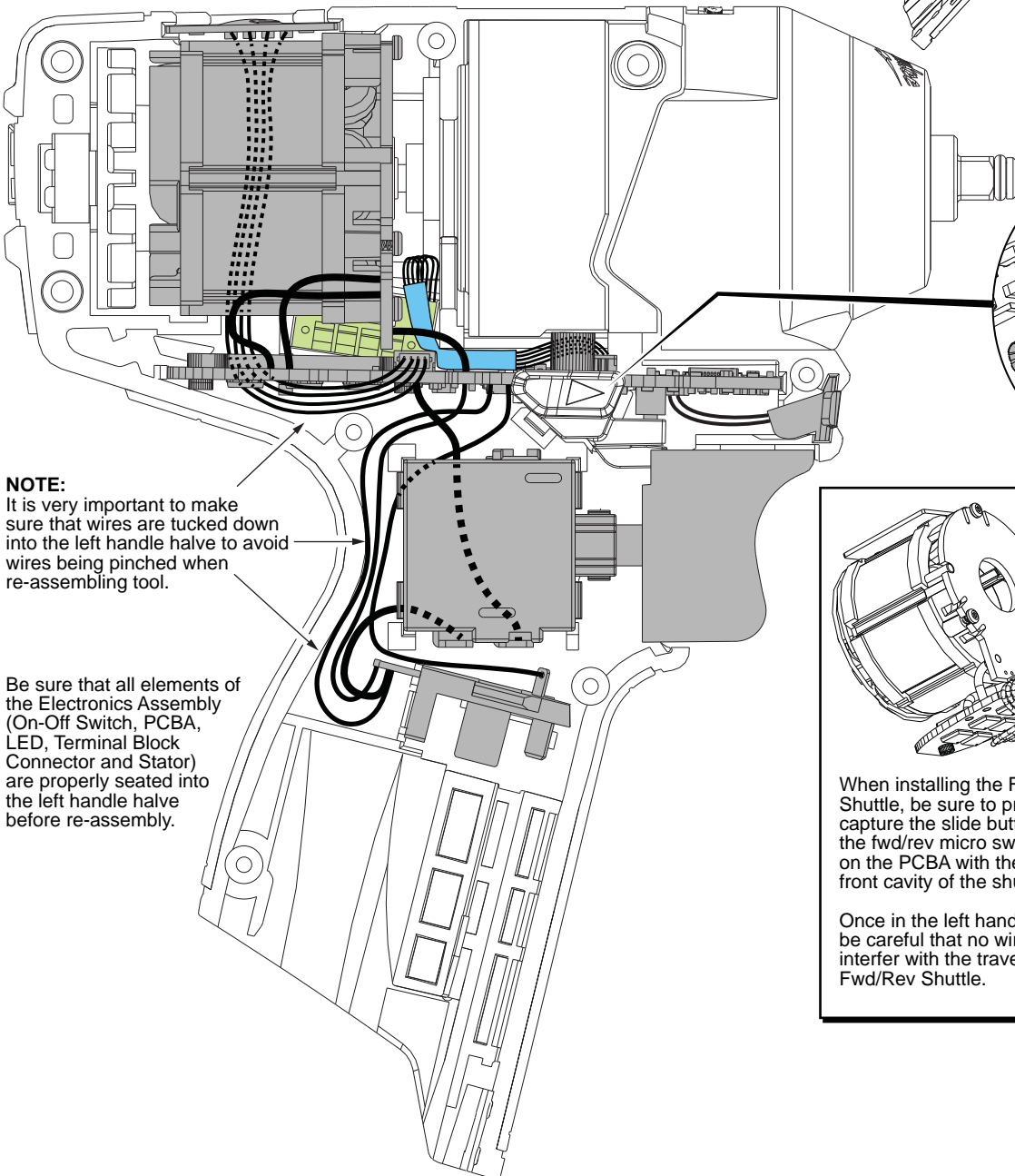

**NOTE:**  
It is very important to make sure that wires are tucked down into the left handle halve to avoid wires being pinched when re-assembling tool.

Be sure that all elements of the Electronics Assembly (On-Off Switch, PCBA, LED, Terminal Block Connector and Stator) are properly seated into the left handle halve before re-assembly.

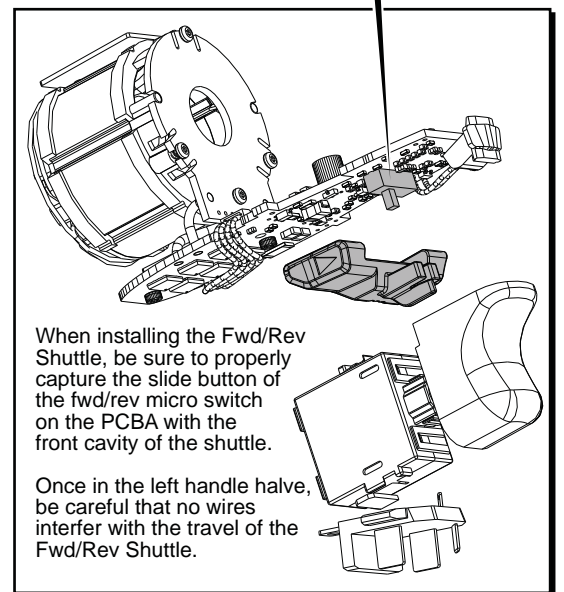
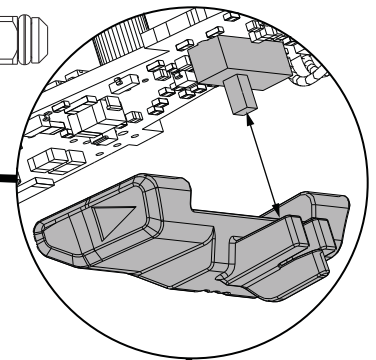

When installing the Fwd/Rev Shuttle, be sure to properly capture the slide button of the fwd/rev micro switch on the PCBA with the front cavity of the shuttle.

Once in the left handle halve, be careful that no wires interfere with the travel of the Fwd/Rev Shuttle.