

WIRING INSTRUCTIONS

TITLE

INTERNATIONAL ROTARY HAMMER

BULLETIN

58-03-1775

MILWAUKEE ELECTRIC TOOL CORP. 13135 WEST LISBON RD. BROOKFIELD, WIS.

DATE
June '97

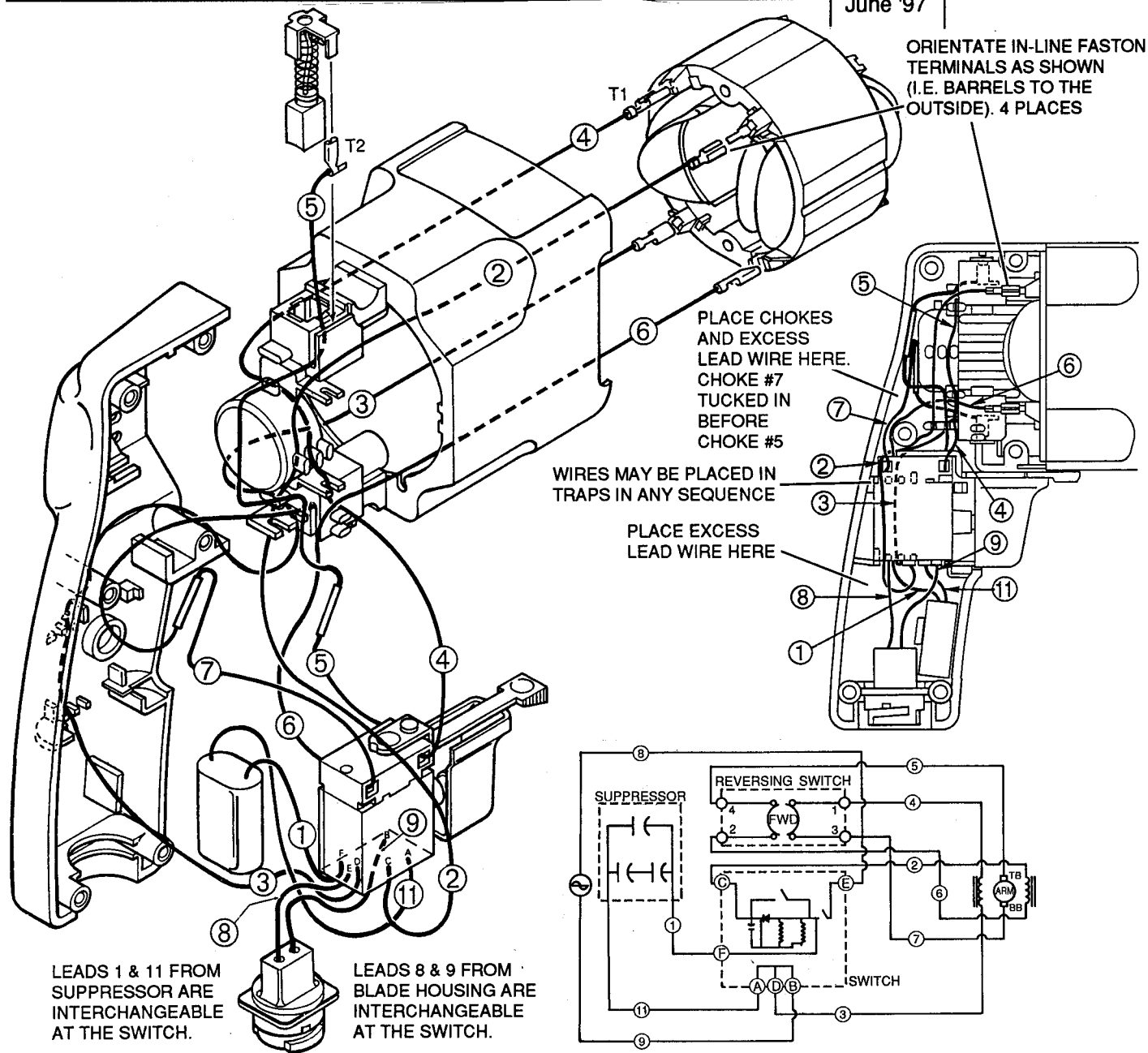

WIRING SPECIFICATIONS

Wire No.	Wire Color	Origin or Gauge	Length	Terminals, Connectors and 1 or 2 End Wire Preparation
1	BLACK	SUPPRESSOR	1.5"	STRIP .27" AND TIN
2	BLUE	23-94-6560	6.5"	STRIP .27" AND TIN / STRIP .15 FOR T1
3	BLACK	23-94-6305	5.5"	STRIP .27" AND TIN / STRIP .15 FOR T1
4	WHITE	23-94-6565	4.75"	STRIP .27" AND TIN / STRIP .15 FOR T1
5	BLACK	23-94-5375	4"	STRIP .20" AND TIN / STRIP .20" FOR T2
6	BLUE	23-94-6270	3.1"	STRIP .20" AND TIN / STRIP .15 FOR T1
7	BLACK	23-94-5370	6"	STRIP .20" AND TIN / STRIP .20" FOR T2
8	BROWN	BLADE HSG.	---	COMPONENT OF BLADE HOUSING ASSEMBLY
9	BLUE	BLADE HSG.	---	COMPONENT OF BLADE HOUSING ASSEMBLY
11	BLACK	SUPPRESSOR	1.5"	STRIP .27" AND TIN

NOTE:

All leads must be held to $\pm .125"$.
All field leads to be measured from and perpendicular to laminations.
All lead lengths are before stripping.

TERMINAL DESCRIPTION

Code	Part No.	Qty.
T1	23-74-1060	4
T2	23-74-0900	2

CONNECTOR DESCRIPTION

Code	Part No.	Qty.