



# Water Coolers

## RADII™ COUNTER-TOP DRINKING FOUNTAIN

### F300R

#### Suggested Specification

Model F300R is a non-refrigerated, stainless steel, self-rimming drinking fountain for direct connection to a cold water supply or for use with remote water chiller. Shall be listed by Underwriters' Laboratories to U.S. and Canadian standards and conform to European Union Directives.

#### Model

F300R is a non-refrigerated drinking fountain

#### Standard Features

- > Waterways are Lead-Free in Materials & Construction
- > Satin Finish Stainless Steel Surfaces
- > Anti-Splash Ridge
- > Built-in Pressure Regulator Assures Smooth, Steady Water Flow
- > Limited 1-Year Warranty

#### Finishes

- > Standard Bowl Finish: Stainless Steel
- > Optimal Bowl Finish: Regency Bronze

#### Installation

- > Prior to roughing-in, consult local, state and federal codes for proper mounting height.
- > Shipped with instructions and mounting clamps.



Components in this fountain are lead free as defined by the Safe Drinking Water Act Amendments of 1986, and the Lead Contamination Control Act of 1988.

Limited 1-Year Warranty (Continental limits of the United States and Canada): One year from date of installation on parts only.

Export Warranty: One year on component parts.

Models covered by this specification comply with all known Plumbing Codes. Listed by Underwriters' Laboratories to U.S. and Canadian standards and conform to European Union Directives.



Certified to NSF/ANSI 61/ Section 9

Physical Dimensions In Inches						
Model	Style	Height	Width	Depth	Extended From Wall	Net Weight Approx.
F300R	Counter-Top	3 1/2"	14"	14"	n/a	9 lbs.

Specifications subject to change without notice

# OASIS® RADII™ COUNTER-TOP DRINKING FOUNTAIN MODEL F300R

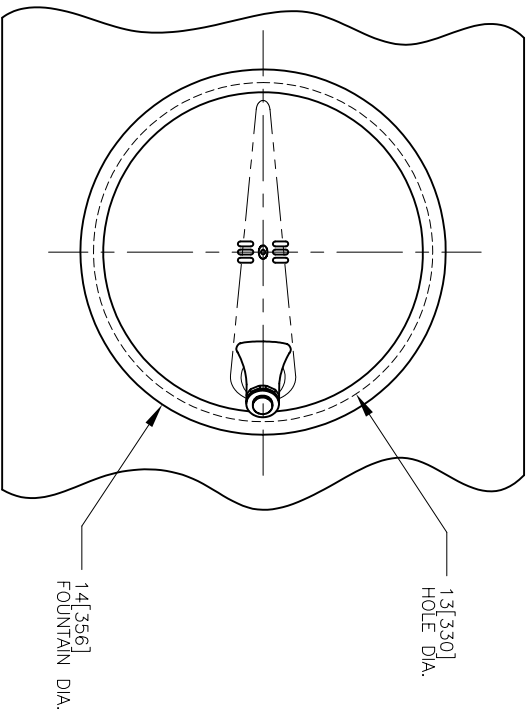

## MOUNTING FOUNTAIN TO COUNTERTOP

1. CUT A 1 3/32 [3.30] DIA. HOLE IN THE COUNTERTOP IN THE DESIRED LOCATION.
2. LAY A BEAD OF SEALING COMPOUND 1/8 [3] WIDE BY 1/8 [3] THICK AROUND THE BOTTOM LIP OF THE FOUNTAIN.
3. POSITION THE FOUNTAIN IN THE COUNTERTOP HOLE.
4. SCREW IN SEVERAL THREADS OF THE (4)FOUR SCREWS PROVIDED INTO THE CLIP ASSEMBLIES. ENGAGE THE CLIP ASSEMBLIES IN THE RETURN FLANGE OF THE FOUNTAIN (DETAIL 'A') AND TIGHTEN THE SCREWS TO SECURE THE FOUNTAIN TO THE TOP. NOTE, EQUALLY SPACE THE (4)FOUR CLIP ASSEMBLIES AROUND THE FOUNTAIN.
5. WIPE AWAY ANY EXCESS SEALING COMPOUND AROUND THE FOUNTAIN.
6. CONNECT PLUMBING. CHECK FOR LEAKS.

### NOTES:

1. ALL DIMENSIONS ARE IN INCHES. DIMENSIONS IN BRACKETS [ ] ARE IN MILLIMETERS.
2. TRAP AND STOP VALVE NOT FURNISHED.
3. NOTE: THE FOLLOWING STATES REQUIRE A LICENSED PLUMBER TO INSTALL FOUNTAIN; AR, GA, MA, MI, OK, RI, SC, SD, TX, VT, AND WI. CA, KS, MN, NM, AND OR ALLOW FOR A STATE-REGISTERED INSTALLER OR CONTRACTOR AS WELL. STATE AND LOCAL PLUMBING CODES MAY PROHIBIT THE USE OF SADDLE TAPPING VALVES FOR WATER LINE CONNECTION IN SOME APPLICATIONS. ALL CONNECTIONS MUST CONFORM TO APPLICABLE PLUMBING CODES.

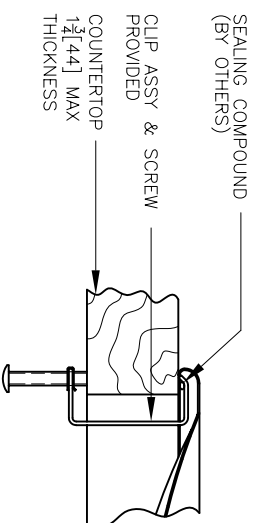
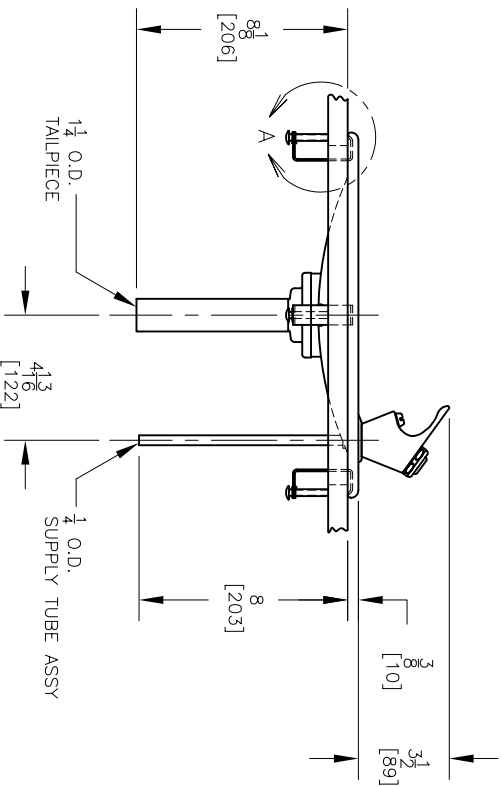

DETAIL A

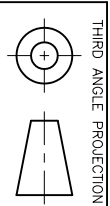

ROUGHING-IN AND DIMENSIONAL DRAWING