

OASIS® Water Coolers

VERSAFILLER®

**Model PWSBF (retro fit) and
PG*SBF Family of Drinking
Fountains/VersaFiller combo**

Installation Instructions

The VersaFiller is an extension of the Aqua Pointe® product line that mounts directly above Versacooler® I and II products. *No additional electrical connections are required.*

If installed onto a refrigerated cooler, then chilled water can be dispensed through the VersaFiller. Otherwise, room temperature water will be dispensed.

The VersaFiller is shipped partially assembled.

On the combo units, the cooler is plumbed and ready to attach to the VersaFiller.



When completed, the finished assembly will look like this:

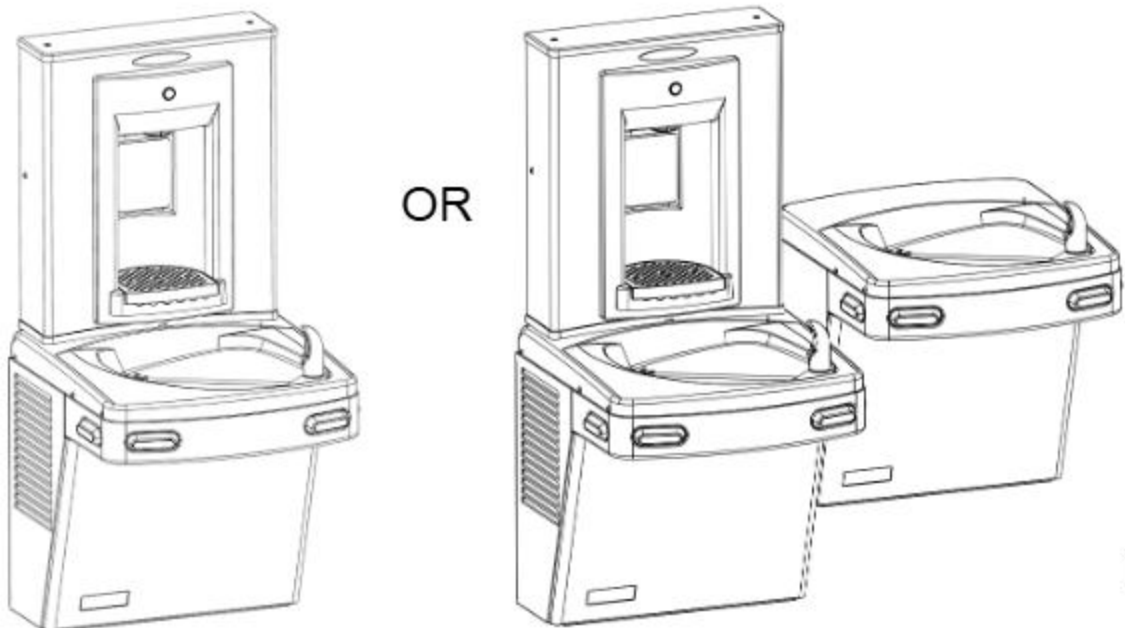

Section 1: Getting Started

What's Included:

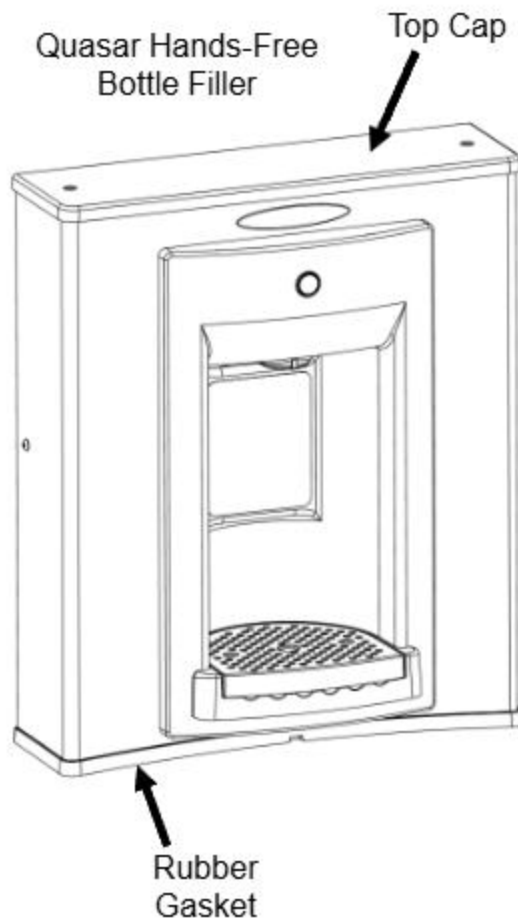

38" of 1/4" OD plastic tubing with 19" of sponge tubing insulation (*included with "Quasar Bottle Filler ready" coolers*)



Snap bushings 7/8"



Quick connect tee fitting



Versafilter II
Versafilter II is optional

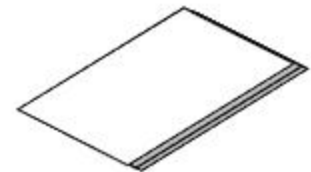

Installation instructions

Tools required:

- 3/8" pilot drill and either a step drill bit up to 7/8" diameter that will drill through SS top or 7/8" diameter punch die (retrofit version only)
- Electric drill; wrench for punch die
- Small tubing cutter for copper tube
- 1/4" nut driver
- #2 Phillips screw driver
- #15 torx bit driver

Section 2: Rough In Drawing

Oasis PWSBF: Versacooler® II Models PGAC, PG8AC with Hands-Free Bottle Filler

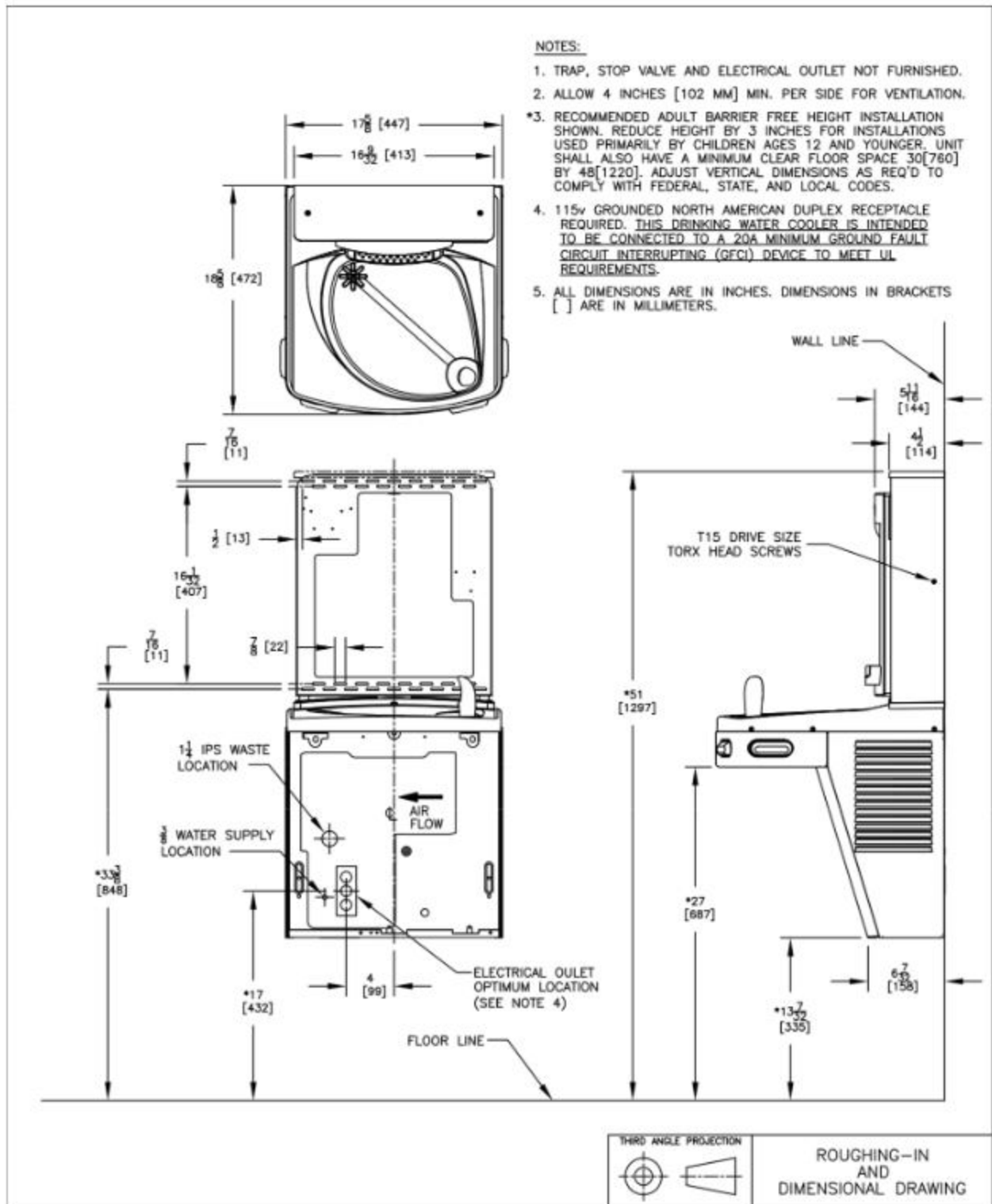

Section 2: Rough In Drawing

Oasis PWSBF: Versacooler® II Split Level Models with Hands-Free Bottle Filler

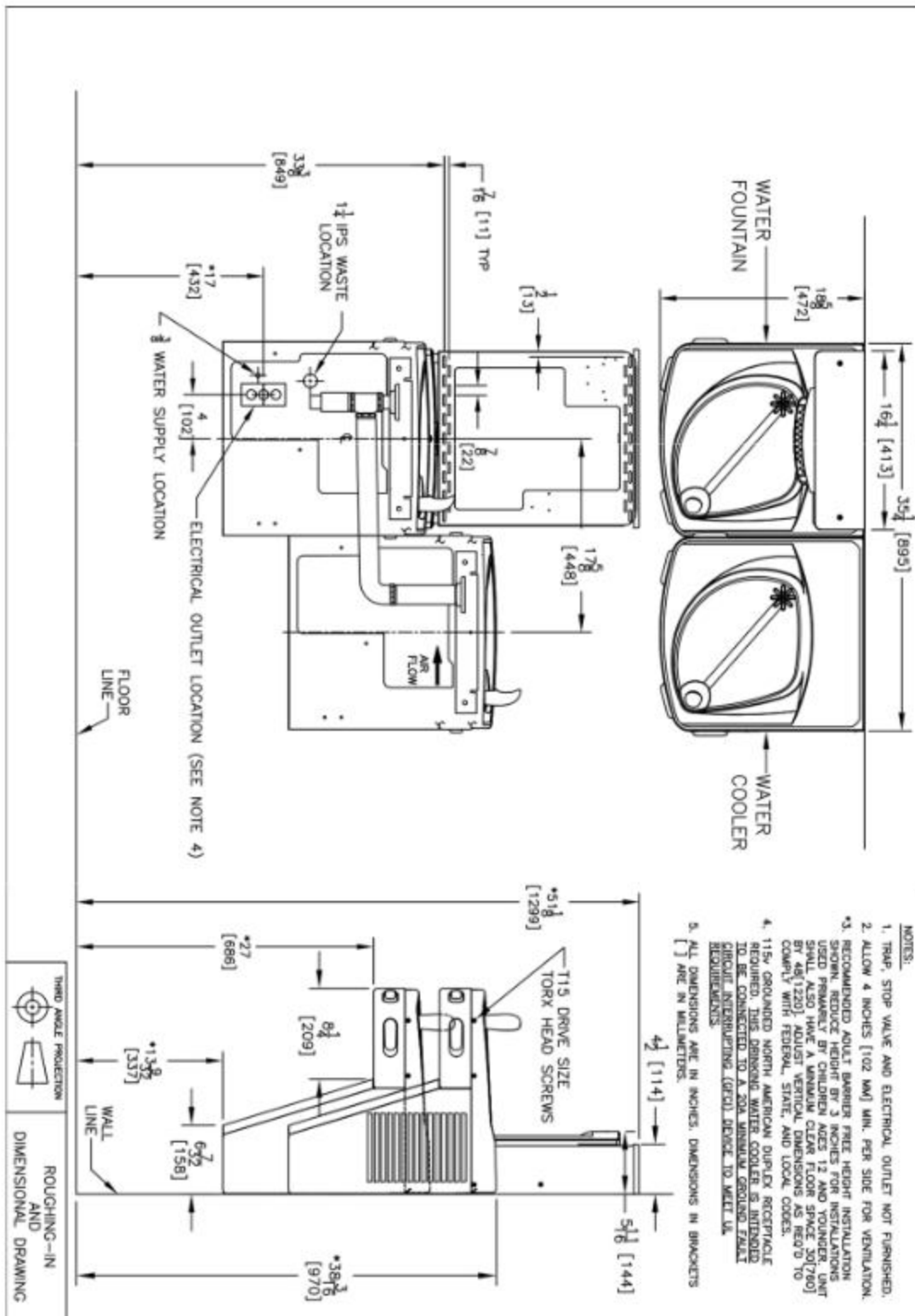

* On split level models, the Bottle Filler must be mounted on the low unit in order to meet ADA guidelines.

Section 3: Installation

Note: Proceed to Section 3B Step 5 “Final steps for both product families” if the cooler is purchased “Quasar Bottle Filler or Versafiller ready”.

A: Drilling hole in the top for water line connection.

1. Disconnect power by UNPLUGGING unit. It might be necessary to remove the front panel to get access to the power.
2. Turn OFF water supply to the unit. It might be necessary to remove the front panel to access the water stop valve.
3. Place hole template onto cooler top so it is aligned with the left side of unit and wall. SEE NEXT PAGE FOR TEMPLATE
4. Mark hole location
5. Remove top from unit.

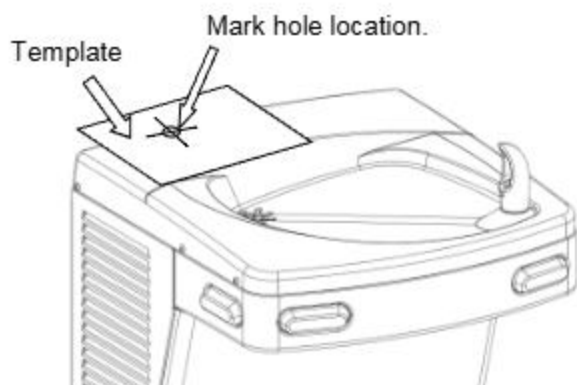

Remove top from cooler by removing six, #15 torx head screws on sides of top.

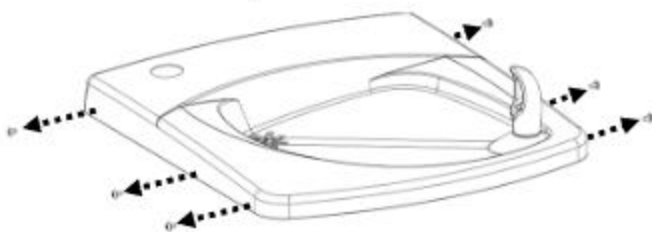

6. Using a step drill bit or 7/8" punch die, make a 7/8" hole through top. You may want to drill a pilot hole to get these started.
7. Install snap bushing into hole to protect tubing from being cut.

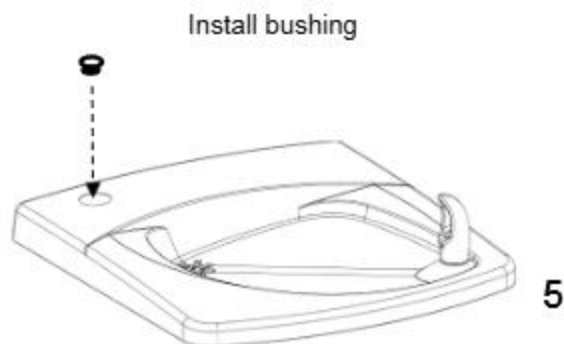
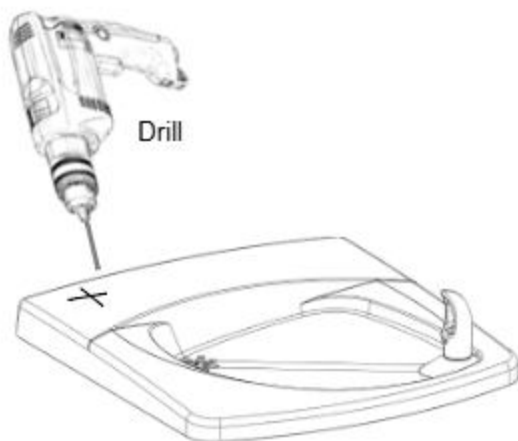

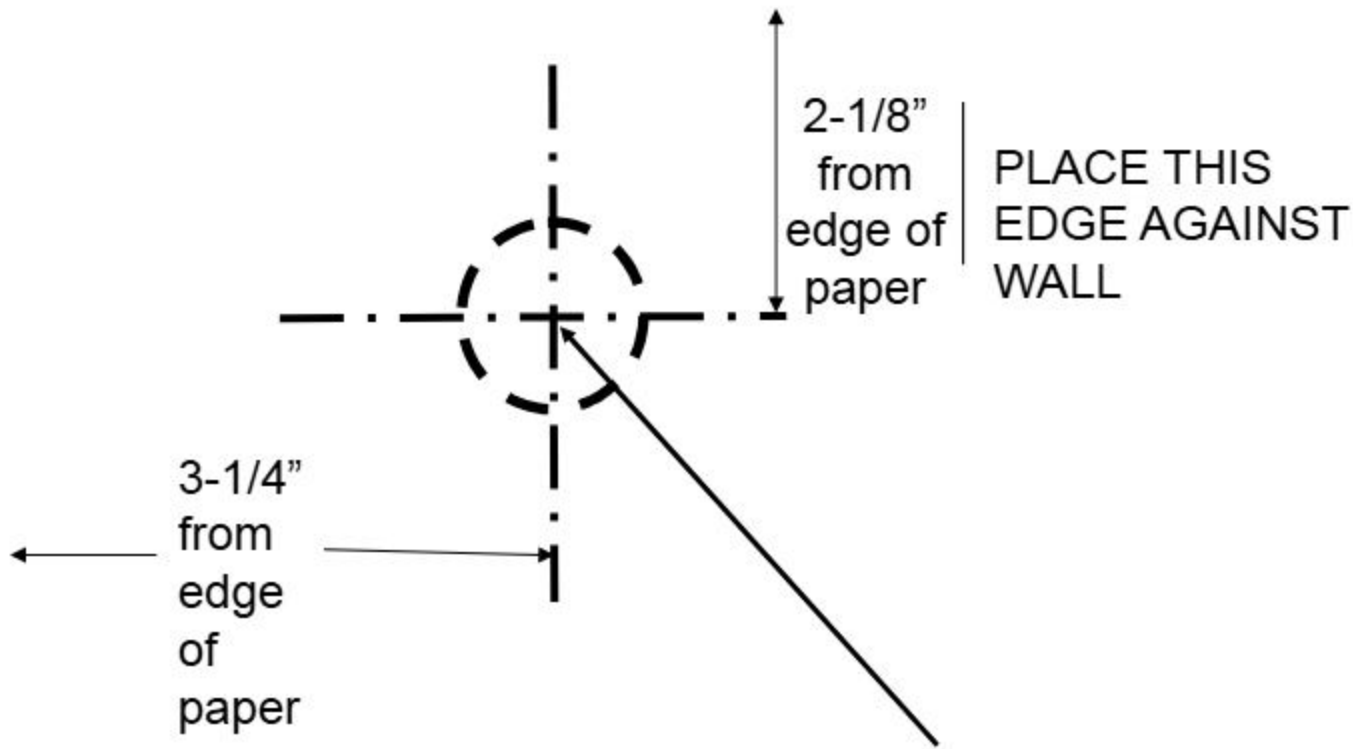

2-1/8"
from
edge of
paper

PLACE THIS
EDGE AGAINST
WALL

3-1/4"
from
edge
of
paper

ALIGN THIS
EDGE WITH LEFT
EDGE OF
COOLER TOP

Mark this center point on the top. Remove the top from the cooler. Then create a 7/8" diameter hole through the top at the marked center point (step drill bit or punch die).

USE THIS TEMPLATE TO MARK THE
HOLE LOCATION ON COOLER TOP

Section 3A: Installation

Versacooler to Bottle Filler Plumbing Diagram

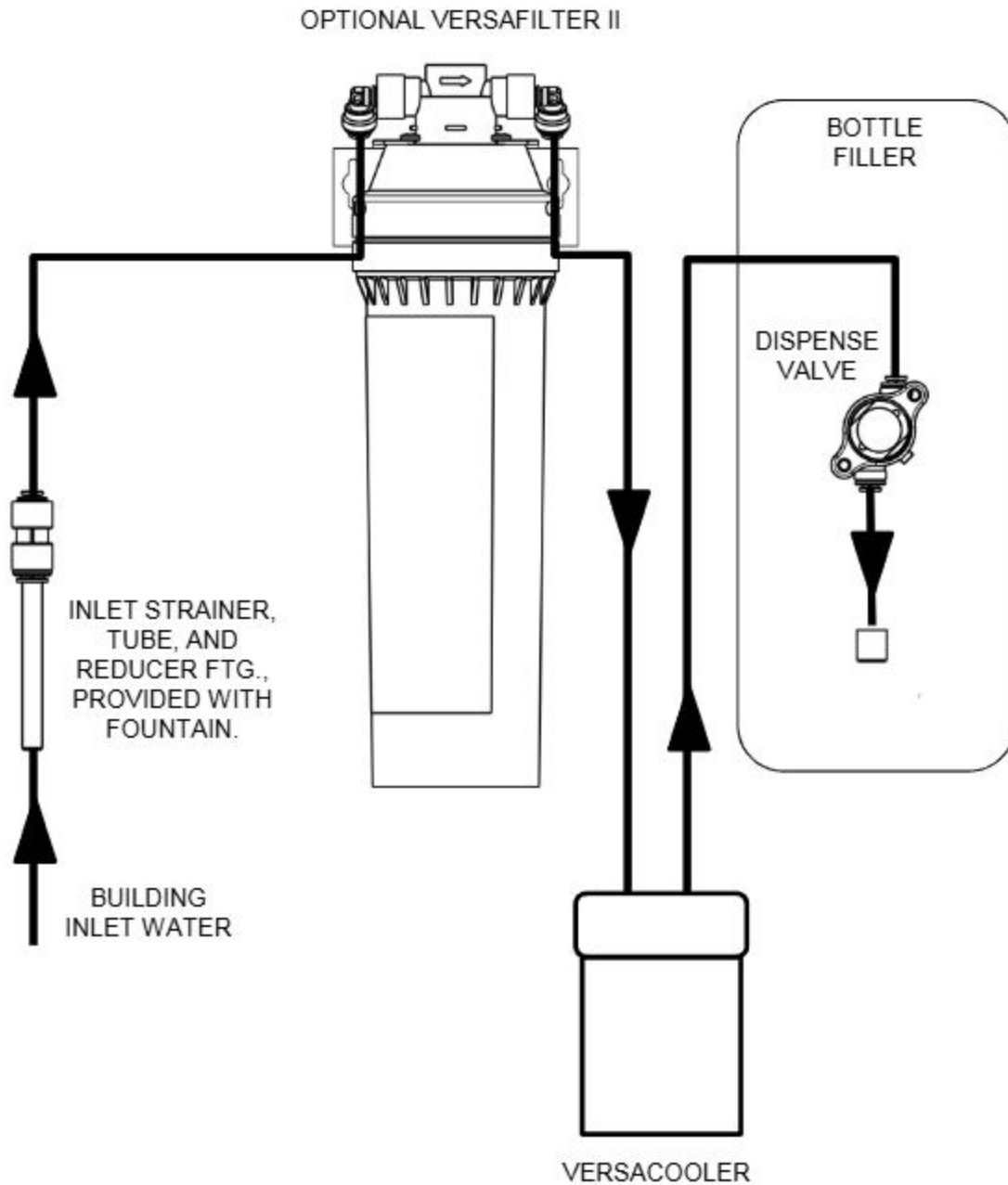

Section 3A: Installation

Two Versacoolers to Bottle Filler Plumbing Diagram

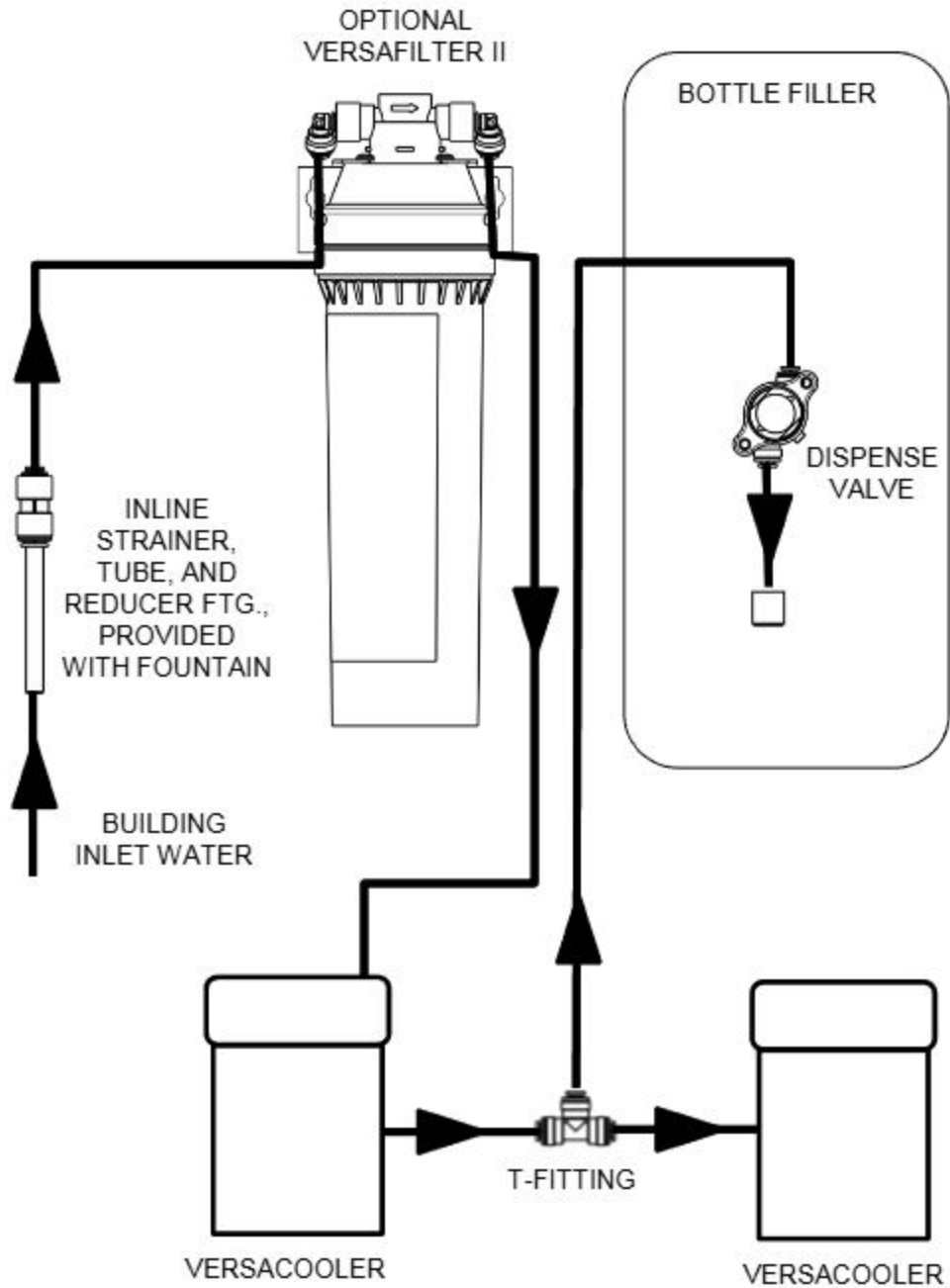

Section 3B: Installation

B: Connecting the water line

Note: If you are retrofitting the Versafiller to an existing cooler, follow the instructions starting on page 11.

For the single “Versafiller ready” cooler, the tube to connect to the Versafiller is found inside the access panel (the compressor compartment). This tube supplies cold water from the cooling tank to the Versafiller.

1/4" OD tube to connect to Versafiller (no tee is needed)



For split level “Versafiller ready” coolers, the tube to plumb in the Versafiller is packaged in the dummy unit.

Remove tube from bag.



First, remove plug from fitting on tank drain



Next, insert end of tube into fitting.



Tee and tube to Versafiller are packaged with PWSBF unit. One branch of tee will supply valve on dummy unit. Other branch of tee will connect to Versafiller. **Note:** "Versafiller ready" single units do not use tee since water line from cooling tank only supplies water to bottle filler.

Tube to connect valve on dummy unit



Tube to connect Versafiller

Tube to connect chilled water to dummy unit and Versafiller



Go to Step 5 "Final steps for both product families:"

To retrofit the Verafiller to an existing unit, follow the instructions below:

If the cooling tank is non-pressurized, then go to the “Pressurizing the cooling tank” addendum section. Otherwise, proceed to step 1 below. Non-pressurized units are single units made since December of 2009. Refer to the schematic below to identify the system that you have.

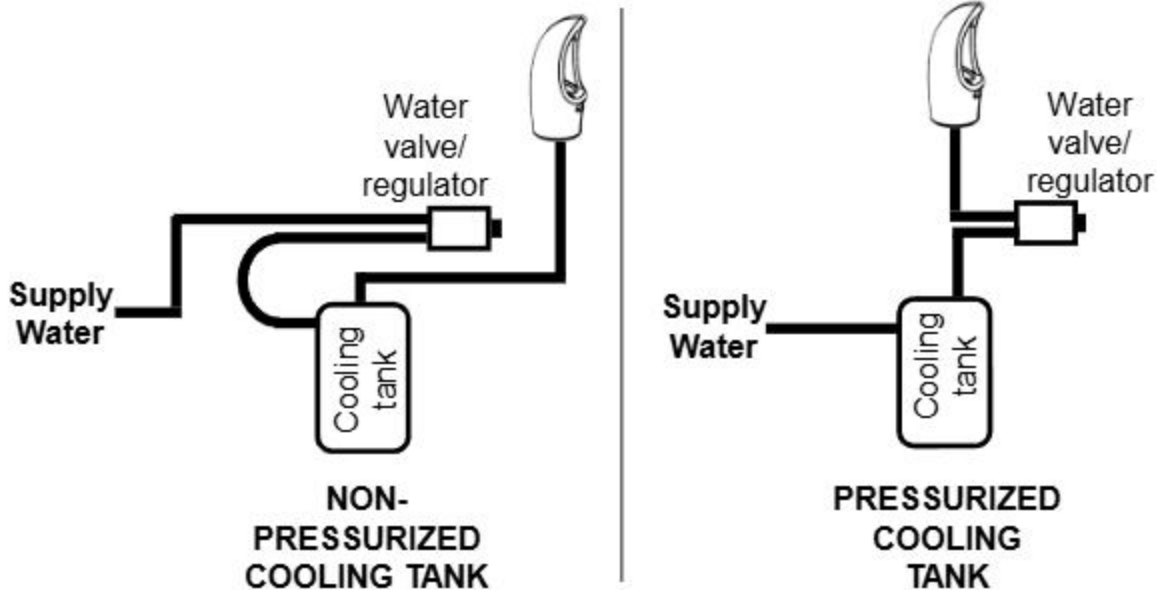

1. With the cooler top removed, find the tube going from the cooling tank outlet to the valve. The TEE fitting (supplied) will need to connect between the cooling tank and valve.

Outlet Tube (insulated plastic)



P8AC family

Outlet Tube (insulated copper)

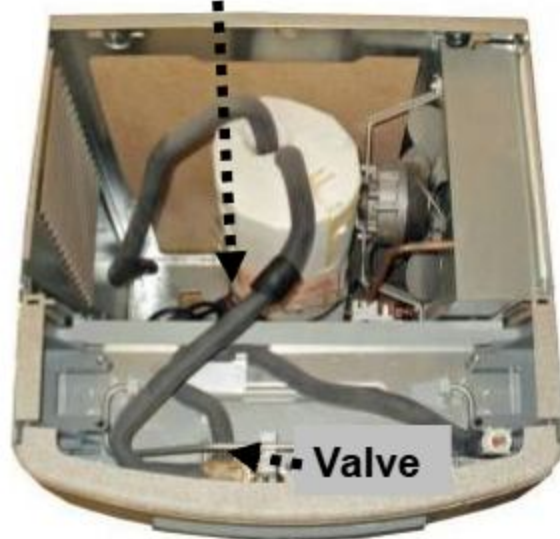

P8AM family

Section 3B: Installation: For the P8AC Version: Versacooler II

2. Disconnect tubing from the elbow on the valve.



3. Using the 38" piece of tubing provided, cut 6" and install it on the end of the TEE. Install the remaining tubing onto the branch of the TEE. Connect the other end of the TEE to the tank outlet tubing (tube that was disconnected from the elbow).

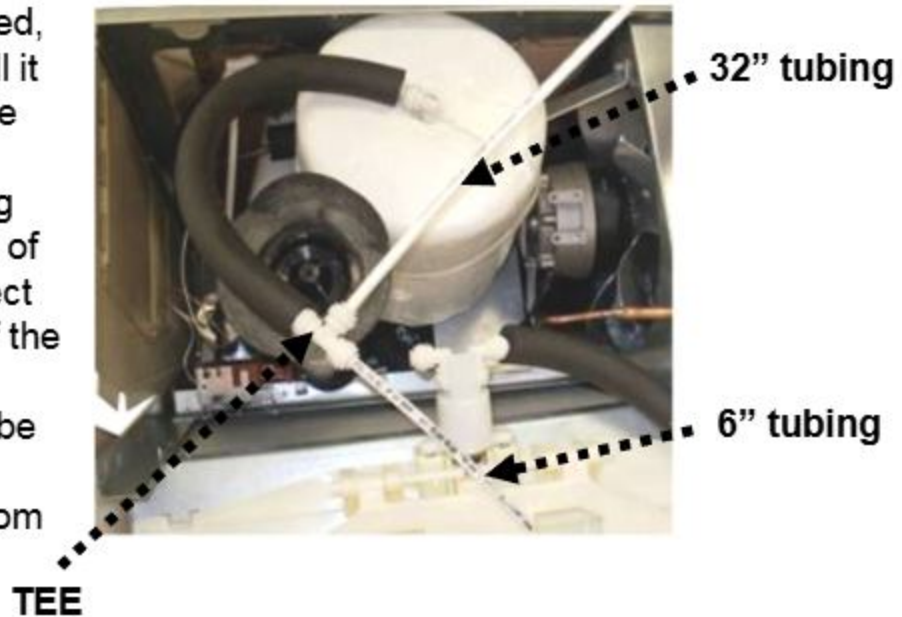

4. Route the TEE and tubing under the waste drain and connect the 6" length to the water valve elbow.



Go to Step 5 "Final steps for both product families:"

Section 3B: Installation: For the P8AM Version: Versacooler I

2. Remove tar tape from the insulation on the outlet tube.



3. Pull back insulation and cut the copper tube with a tubing cutter. Cut where there is at least 1 inch of *straight* tubing on each side of the cut.



4. Install TEE fitting by connecting the copper tubing to each end. Then install the 32" piece of plastic tubing to the TEE branch.



32" plastic tubing (supplied)

Section 3B: Installation: Final steps for both product families:

5. Feed tube up through the top and attach the top to the cooler.

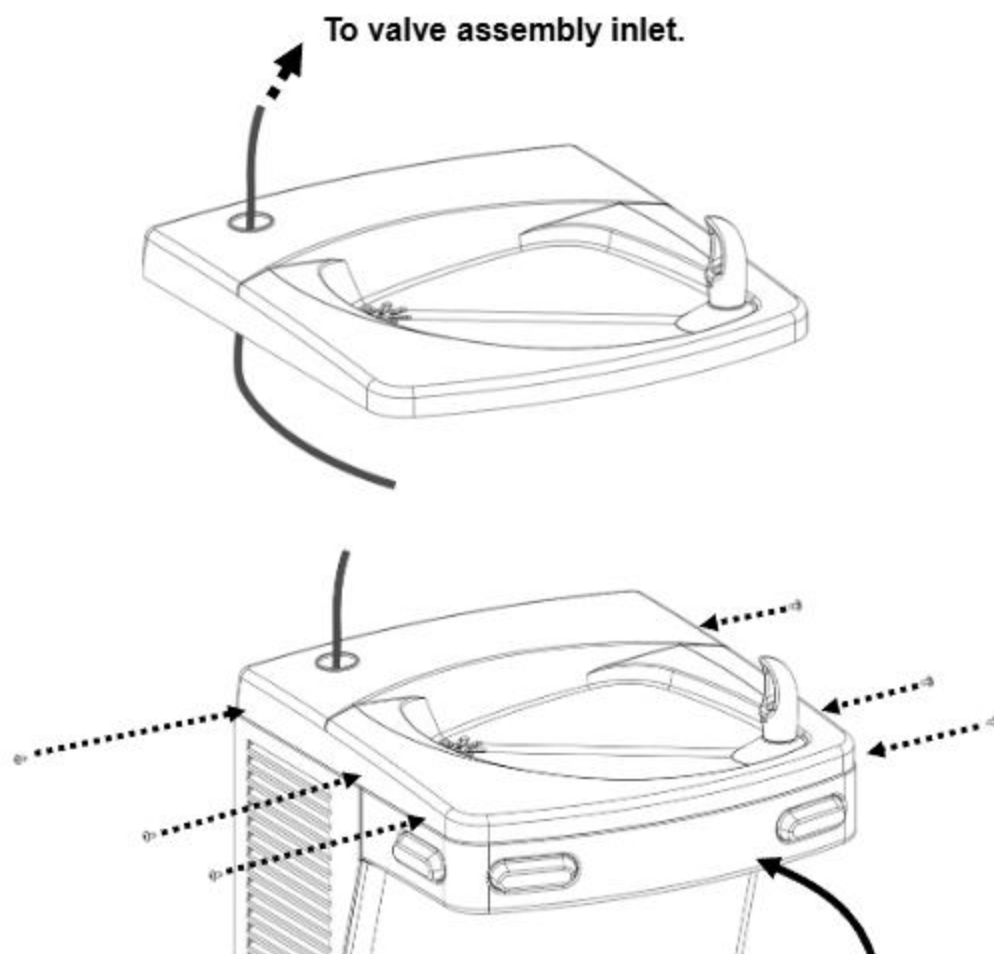

TIP: For the P8AM, it is easier to connect the outlet tube to the bubbler if the front nose is removed.

Section 3C: Installation of the Versafiller Sports Bottle Filler

C: Mounting the frame to the wall

1. Place rubber gasket on top of the cooler so it is centered left/right and against the wall.
2. Set the wall frame onto the gasket. Center it left/right and push it against the wall and mark hole locations for wall fasteners. The gasket will set the frame at the proper height.

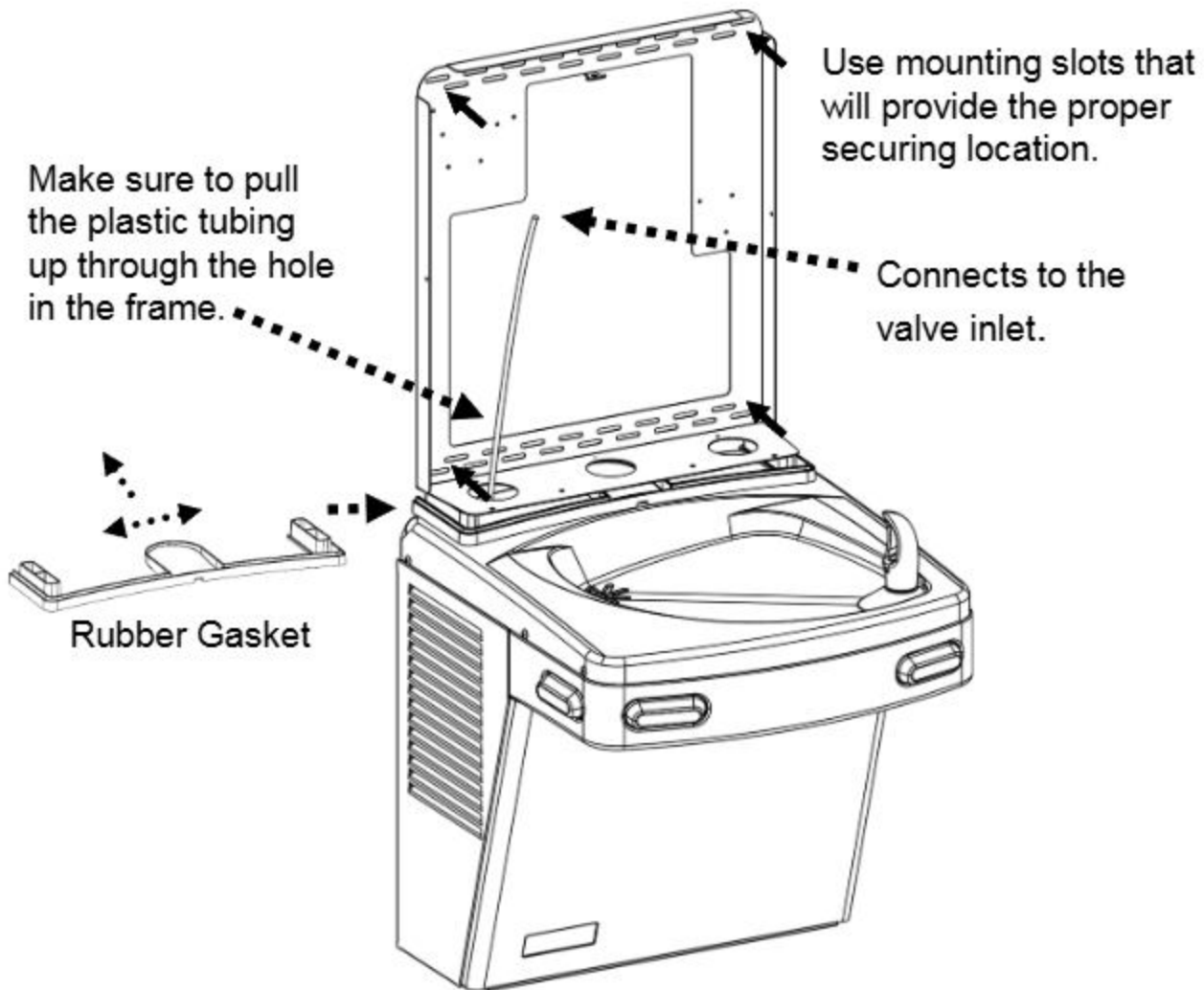

3. Secure frame to the wall with fasteners (not provided). Pull plastic tubing up through the hole in the frame.

D: Attaching the Tether

3. Install bottle filler tether with the steps below.

Attach the tether line assembled to the bottle filler dispense bracket to the cleat on the mounting frame.

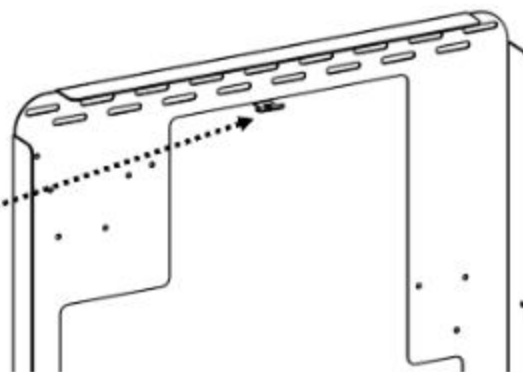

1.

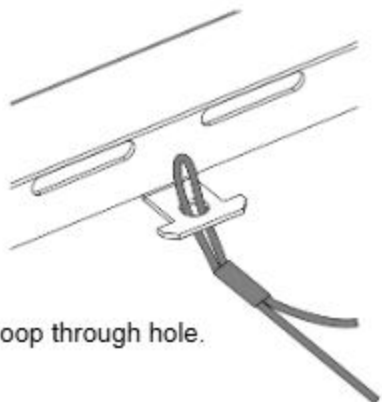

Push loop through hole.

2.

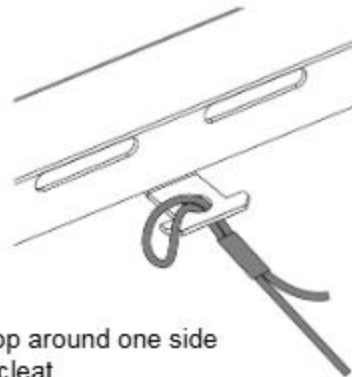

Put loop around one side of the cleat.

3.

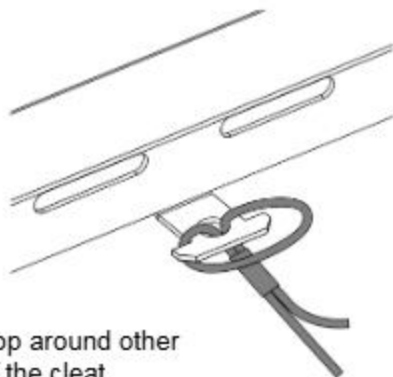

Pull loop around other side of the cleat.

4.

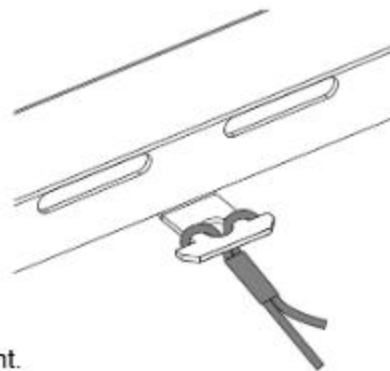

Pull tight.

Section 3: Installation

4. The tether keeps the bottle filler secured to the frame when changing the filter, if installed. Make sure the tether is installed properly to avoid accidental damage to the unit.

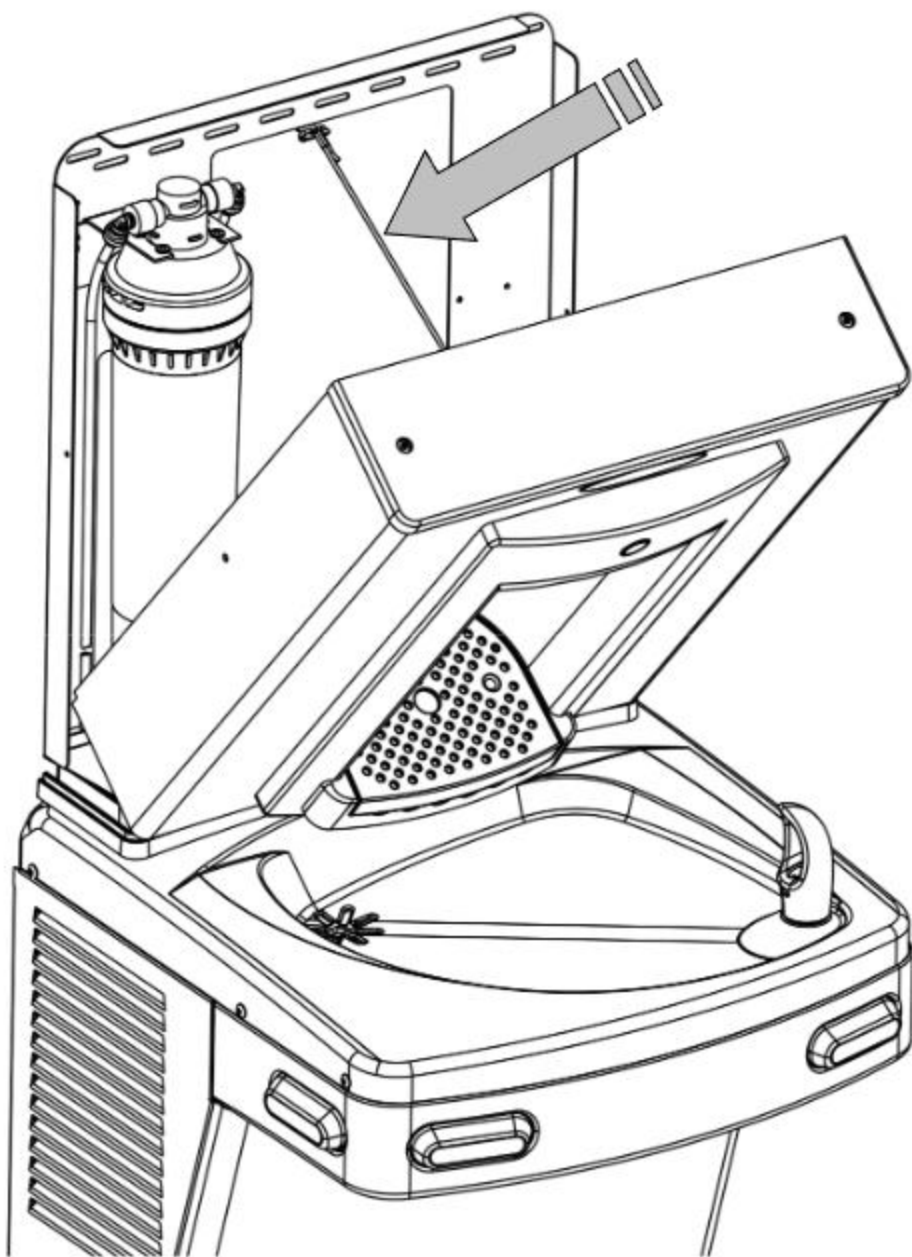

Section 3: Installation

5. Slide sponge tubing insulation over water line. Connect the tubing to the INLET elbow on the back of the VersaFiller assembly.

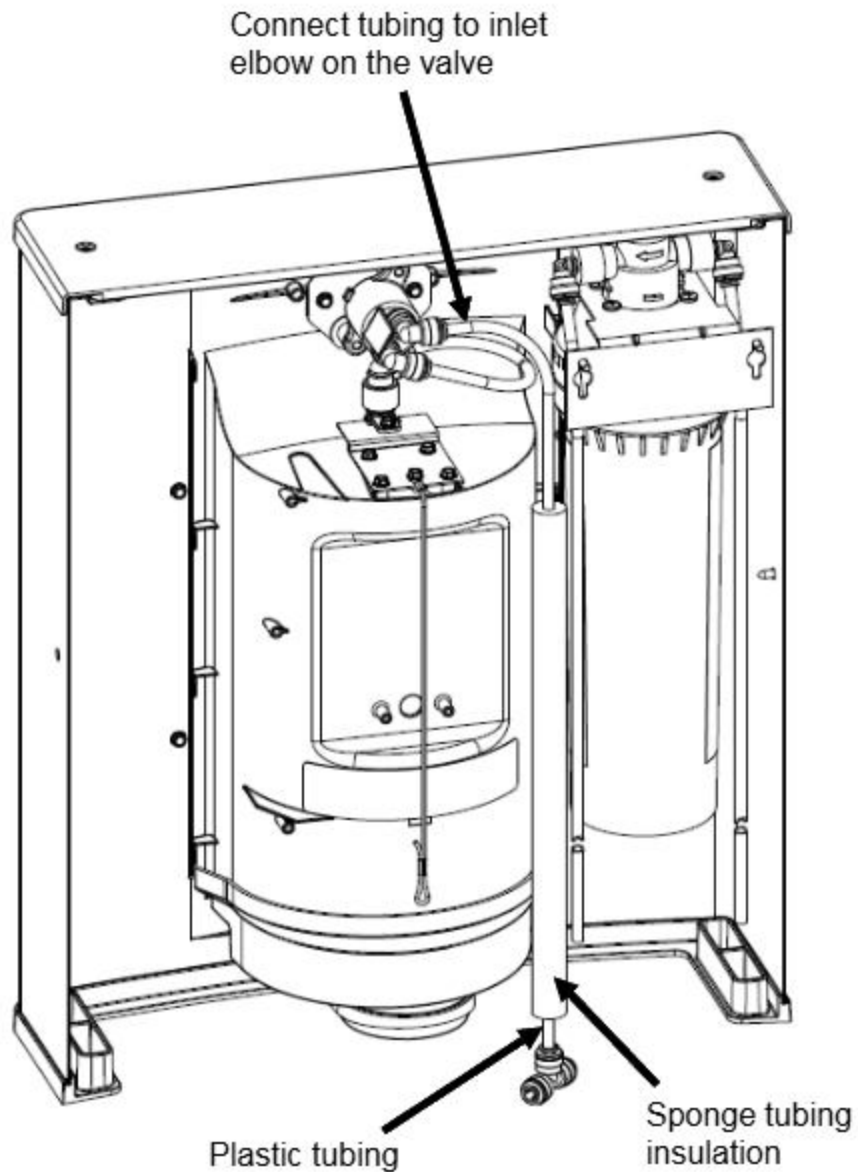

Section 3: Installation

6. Set the VersaFiller cabinet into place. **MAKE SURE** the cabinet fits into the *groove* in the rubber gasket on both sides and front of the wrapper.

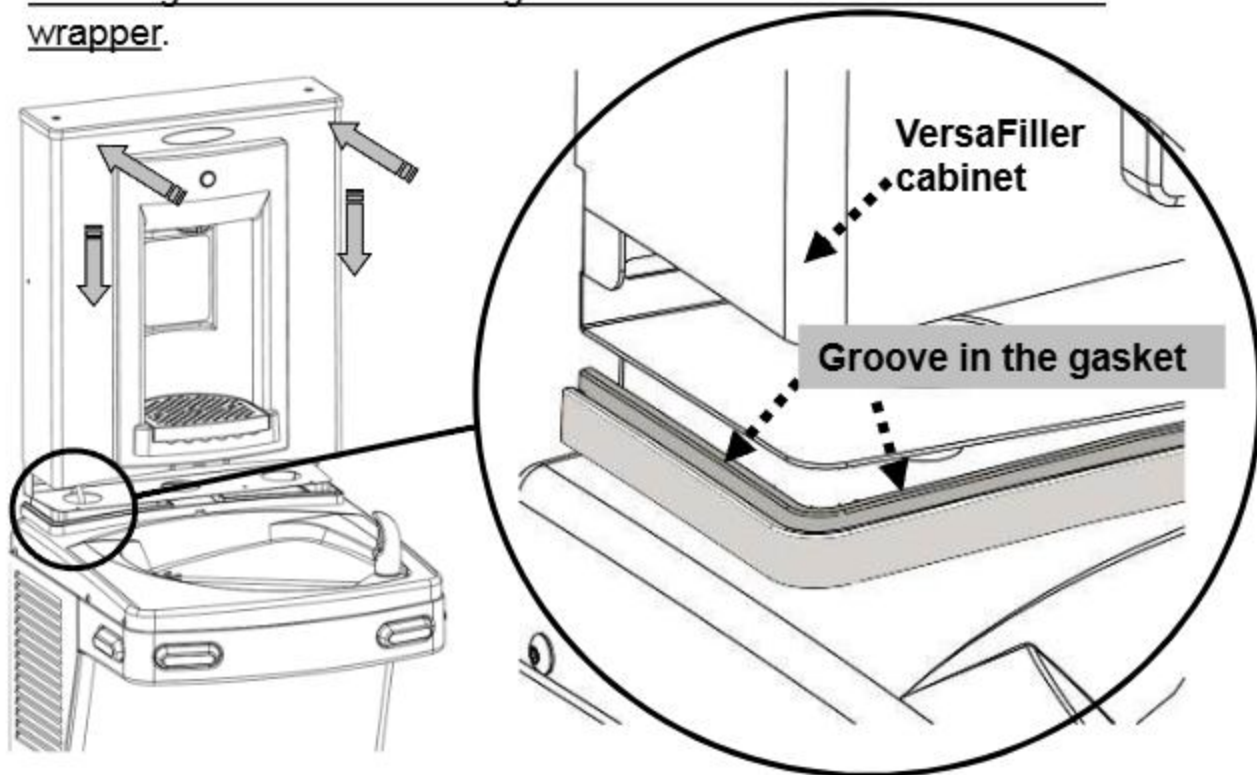

7. Attach VersaFiller assembly and top cap to the frame using the two (2) torx screws.

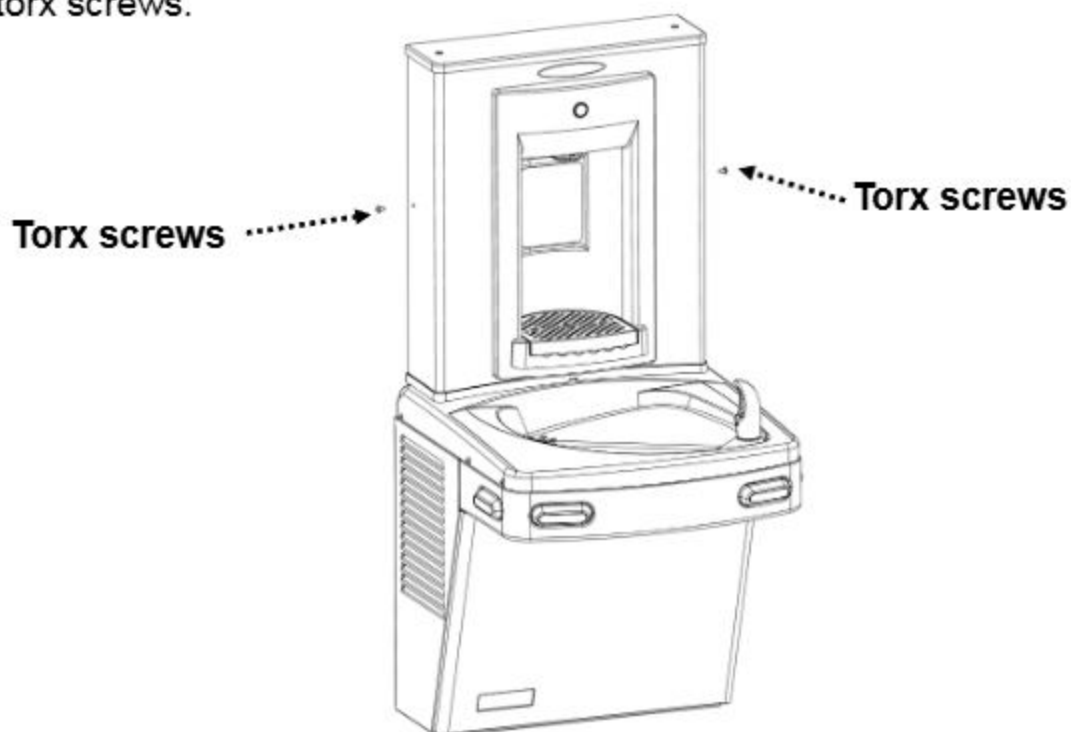

Section 3: Installation

8. Turn ON water supply and check for leaks. Press the activation button and release any trapped air from the system. Plug in the power cord and replace the front panel IF it was removed earlier.

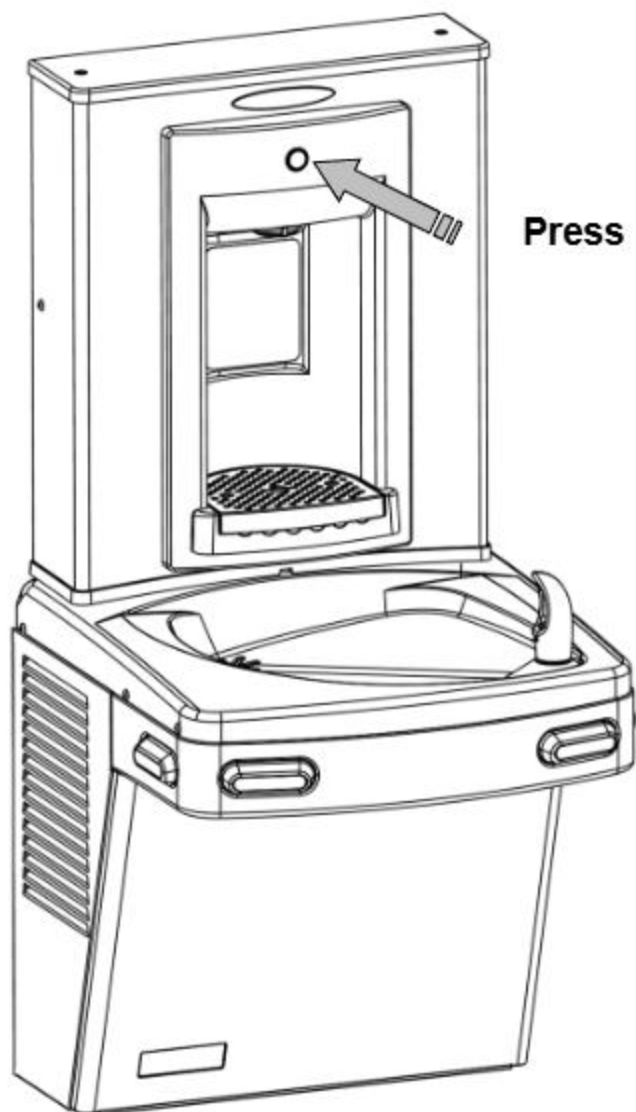

INSTALLATION COMPLETE

Addendum Section: Pressurizing Cooling Tank

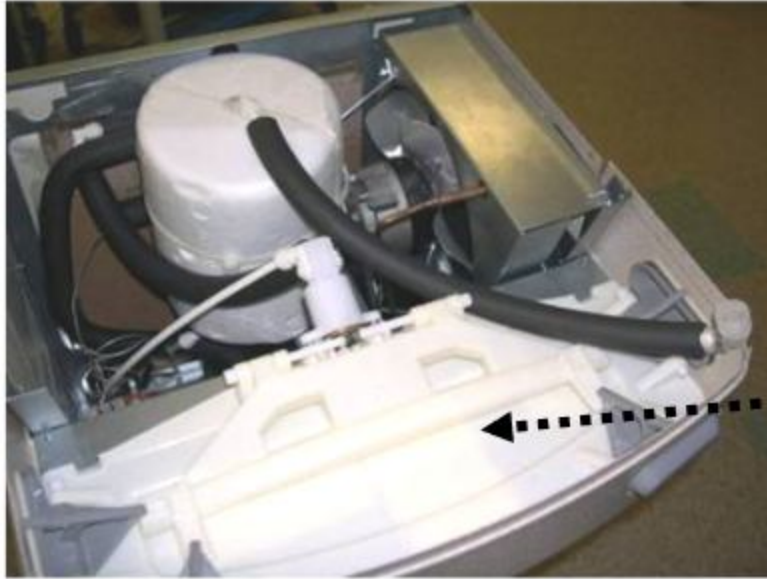

The water should already be turned OFF and the power disconnected.

Unit as it appears with top removed



STEP 1

Unplug un-insulated water line from water valve inlet (JG elbow located left side of water valve facing the front of the cooler). Set tubing aside (careful to not contaminate water contact end).

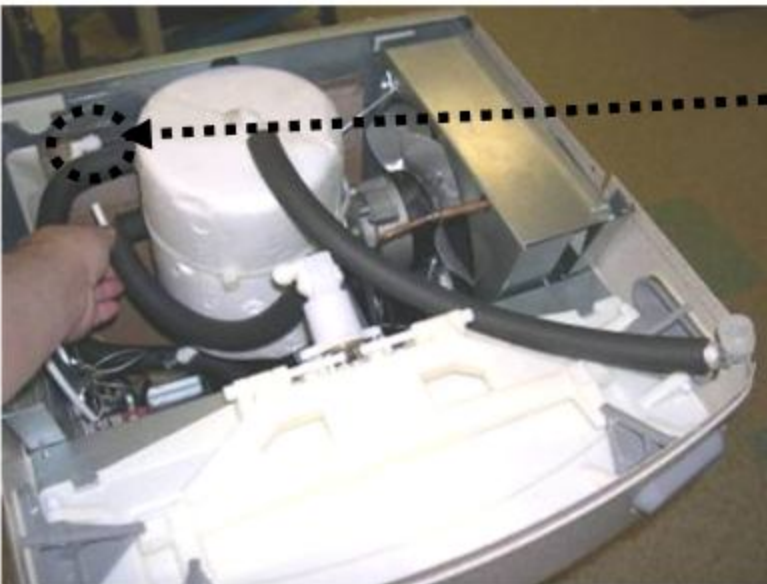

STEP 2

Unplug tubing from JG elbow leading to cooling tank inlet.



STEP 3

Plug un-insulated tubing that was removed in step 1 into JG elbow leading to the cooling tank from step 2.

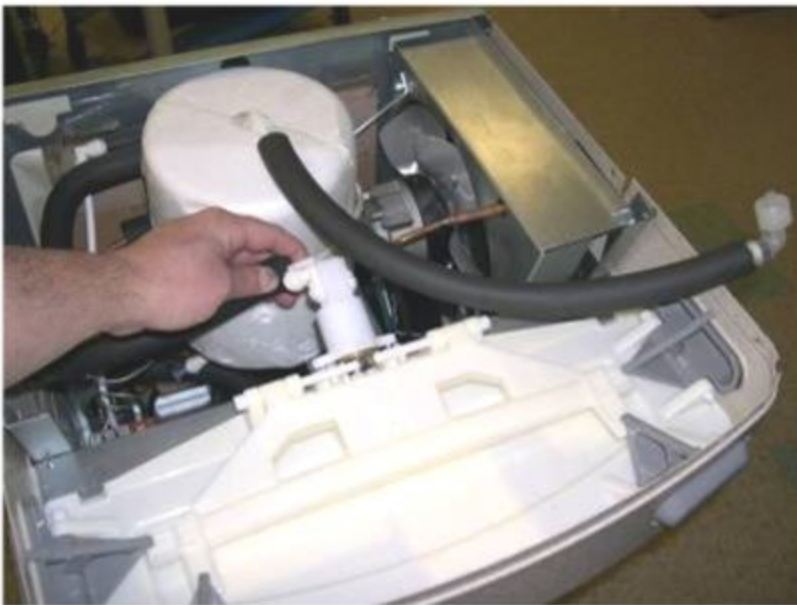

STEP 4

Unplug tubing that is connected to the water valve outlet (JG elbow located on the right side of valve facing the cooler).



STEP 5

Connect tubing from step 4 to JG elbow on the left side of the valve.



Step 6

Unplug JG tubing from the cooling tank outlet. Do not set it down.



Step 7

Using tubing removed in step 6, plug into JG elbow on the right side of the valve. (be sure to rout the tubing under existing tubing installed in step 4 as shown)



Step 8

Using tubing that is connected to the JG elbow left side of valve (done in step 4), and plug the other end to the JG fitting at the top of the cooling tank.

Return to Section 3 B 23
"Connecting the water line"

EXPLODED PARTS BREAKDOWN

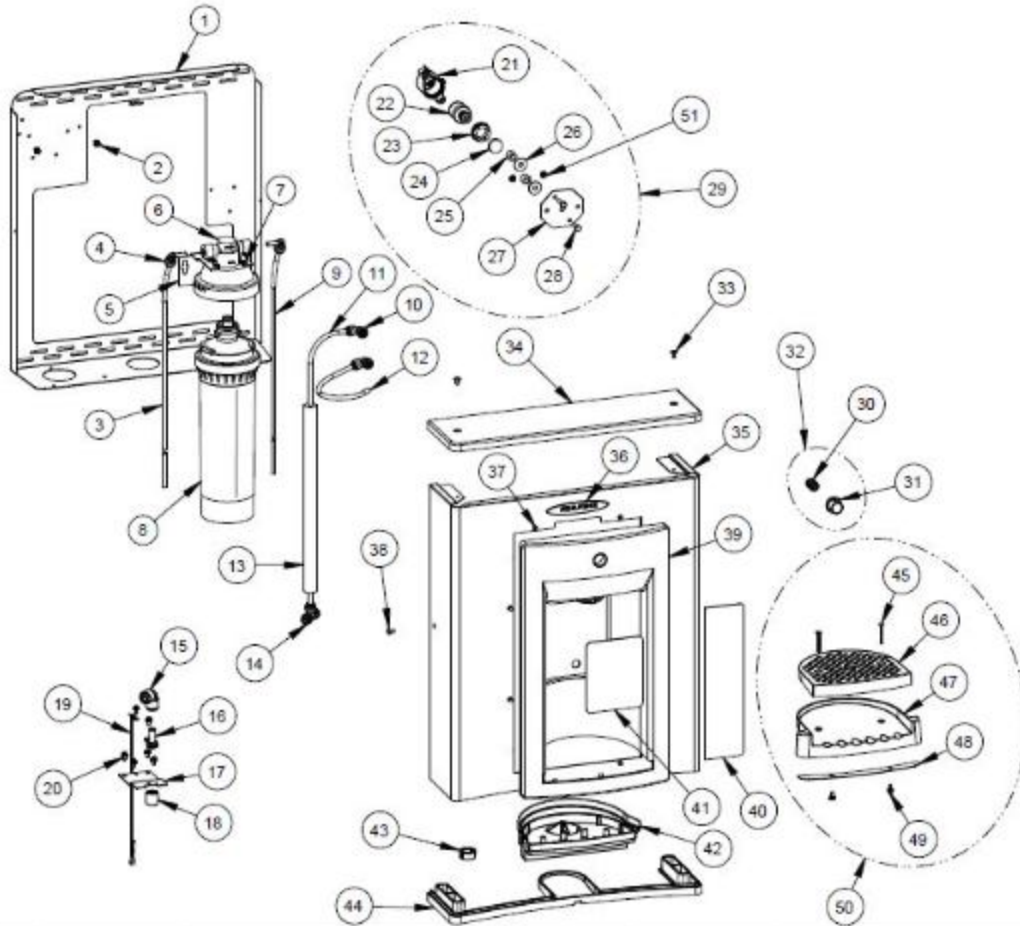

ITEM	QTY	P/N	Description	ITEM	QTY	P/N	Description
1	1	036687-003	FRAME, PWFSBF-K12	27	1	036690-001	BRACKET, VALVE PWSBF
2	1	026642-004	SCREW, HEX HD TAPPING	28	2	026670-007	SCREW, HEX HD MACHINE
3	1	030152-046-SP	TUBE, PE WHITE 38"	29	1	036231-001-SP	VALVE ASSY., PWSBF DISPENSE
4	2	029994-103	FTG, PP ELBOW, PLUG IN	30	1	034649-001	SPRING
5	1	041073-001	BRKT, VERSAFILTER II	31	1	036194-002	BUTTON, PWSBF
6	1	041072-001	FILTER HEAD, VERSAFILTER II	32	1	036702-001	BUTTON ASSY., PWSBF SERVICE
7	4	026630-022	SCREW, PAN HD TAPPING	33	2	031875-003	SCREW, TRUSS HD TAPPING TORX
8	1	041071-001	FILTER CARTRIDGE, VERSAFILTER II	34	1	036686-001	CAP, PWSBF
9	1	030152-014	TUBE, PE WHITE 48.0"	35	1	036691-006	WRAPPER, PWSBF
10	2	028481-101	FTG, PP UNION, ELBOW WHT 0.25"	36	1	036206-005	INSERT, NAMEPLATE AQUAPOINTE
11	1	030152-046-SP	TUBE, PE WHITE 38"	37	8	026642-003	SCREW, HEX HD TAPPING
12	1	030152-043	TUBE, PE WHITE 8.5"	38	2	031875-003	SCREW, TRUSS HD TAPPING TORX
13	1	017681-008	INULATION, SPONGE TUBE 19"	39	1	036190-003	ALCOVE, EBF
14	1	029199-103	FTG, PP UNION TEE WHITE	40	1	038031-007	LABEL, PANEL
15	1	028482-001	FTG, JG. REDUCING ELBOW	41	1	038031-008	LABEL, ALCOVE SENSOR
16	1	038029-001	ADAPTER, FLOW NOZZLE	42	1	036191-002	DRAIN, MSBF, SHORT
17	1	036209-003	BRACKET, DISPENSE	43	1	027189-008	BUSHING, SNAP
18	1	038032-001	FLOW NOZZLE ASSY	44	1	036689-001	GASKET, PWSBF
19	1	032459P008	LANYARD, BOTTLE FILLER	45	2	036049-002	SCREW, OVAL HD PLASTITE
20	6	026642-003	SCREW, HEX HD TAPPING	46	1	036695-001	TRAY, GRILLE DRIP
21	1	035990-001	HOLDER, CARTRIDGE STEM	47	1	036688-001	TRAY, DRIP PWSBF
22	1	029967-005	CARTRIDGE, 4.25# SPRING	48	1	036697-001	CAP, DRIP TRAY BOTTOM
23	1	A020957	NUT, RETAINING PLASTIC	49	2	026642-003	SCREW, HEX HD TAPPING
24	1	030172-002	PLUG, HOLE	50	1	036701-001	DRIP TRAY ASSY., SERVICE
25	2	028706-036	WASHER, SPACER, NON METAL	51	2	026642-003	SCREW, HEX HD TAPPING
26	2	016377-042	WASHER/SPACER, METAL				

Accessories:

Vandal resistant screw kit: P/N 036704-001, includes torx bits and replacement screws for items 4 and 25.

Gasket, Sunroc/Haws : P/N 036689-101 (replaces item 35): [KIT P/N 036752-001](#)

Gasket, Adapter Elkay/Halsey Taylor P/N 041114-001

P/N 030099-412 Rev H Date: 4/2020
© 2020 LVD Acquisition, LLC

Oasis, Aqua Pointe, Versacooler and VersaFiller are registered trademarks of LVD Acquisition, LLC.

Haws is a registered trademark of HAWS Corporation.

Elkay and Halsey Taylor are registered trademarks owned or licensed by Elkay Sales Inc. and/or its parent Elkay Manufacturing Company



OASIS INTERNATIONAL

222 East Campus View Blvd.
Columbus, OH 43235
614-861-1350
www.oasiscoolers.com