

OASIS® VERSACOOLER® II MODELS PAC, PGAC, PFAC, P8AC, PG8AC, PF8AC, P8ACEE, PF8ACEE, PV8AC SUNROC MODELS ADAAC, ADAFAC, ADA8AC, ADAF8AC, ADA8ACHF, ADAF8ACHF

A. INSPECTION

Inspect the carton and water cooler for evidence of rough handling and concealed damage. Damage claims should be filed with the carrier.

B. TO PUT WATER COOLER INTO SERVICE

- Note:** The following states require a licensed plumber to install cooler; AR, GA, MA, MI, OK, RI, SC, SD, TX, VT and WI. CA, KS, MN, NM and OR allow for a state-registered installer or contractor as well. State and local plumbing codes may prohibit the use of saddle tapping valves for water line connection in some applications. All connections must conform to applicable plumbing codes.
- Locate and install plumbing and electrical service, if required, in accordance with the Roughing-in Drawing. Filter units have additional instructions on a label inside the access panel. Read these before installing unit. This drinking water cooler is designed to be operated at a water supply line pressure of up to 100 psi (690 kPa). A pressure regulator must be installed in front of the unit's water inlet if the water pressure (including any possible pressure spikes) could exceed 100 psi (690 kPa).
- FLUSH BUILDING WATER SUPPLY LINE BEFORE INSTALLING UNIT.
- Install unit on the wall hanger. **Wall hanger is shipped fastened to the back of the unit.**
- Install a trap in the waste line and a shut off valve in the water supply line.** An in-line strainer is furnished in the "Water Supply" tube. Connect the "Water Supply" tube to the shut off valve. This connection should not be a solder joint or flare connection to allow access to the strainer for service. To ease removal of the strainer, a sheet metal screw may be lightly threaded into the open end. When the unit has an internal waste trap, the trap should be wrapped with insulating tape to prevent sweating. Use of the 1-3/4 diameter knockout for a waste line is not recommended because of a potential conflict with ADA* toe space clearance requirements. Check your local building code inspector for approval.
- Rotate the fan blade by hand to see that it is free of obstructions.
- Check the available power supply against the water cooler data plate to assure correct electrical service. This drinking water cooler is intended to be connected to a 20A minimum ground fault circuit interrupting (GFCI) device to meet UL requirements. Plug power supply cord into wall outlet. The rear most 1-3/8 diameter knockout in the frame bottom is for an externally located electrical supply. Make sure the knockout hole edge is smooth and free of any burrs. Use of a Heyco bushing #2184 in the knocked out hole is recommended in order to prevent damage to the service cord and to close up excess opening around the cord. Route the cord so it does not interfere with ADA* space requirements.
- To fill the cold water tank on water cooler versions, open the water supply line shut-off and push any one of the front or side pushbuttons to allow water to flow to the bubbler. On the EE or HF model, actuate the solenoid by holding one hand approximately 3" from the infrared sensor. Run water until stream is free of bubbles.
- To Adjust Bubbler Stream:
 - All Pushbutton models are equipped with a Cartridge Regulator. The P8AC, PAC, PG8AC, PGAC, PF8AC, PFAC, ADAAC, ADAFAC, ADA8AC and ADAF8AC have a slot in the shelf below the Pushbuttons. Insert a screwdriver in this slot to adjust regulator. Turn adjustment clockwise to increase stream height. To access the PV8AC adjustment, remove the Bezel and Button from the front of the cooler.
 - Electric Eye (EE or HF) models have a Regulator built into the Bubbler. If adjustment is needed, insert a 5/64 hex wrench approximately 1-1/8" into the bubbler nozzle opening until it bottoms out and is seated in an adjust screw. Turn the adjust screw clockwise to reduce the stream height or counterclockwise to increase the height. Note, less than one turn is required to go from a closed to a wide open flow. Do not over tighten the adjuster in the closed position as stripping the hex impression in the adjust screw may result. Turn the adjuster 1/16 of a turn at a time.
- On electric eye equipped models, place and then hold hand approximately 3" from the sensor to actuate the solenoid valve. After approximately 30 seconds run time, the sensor will automatically shut off the solenoid valve. To reactivate, move hand away for an instant and then again place it in front of the sensor.
- To adjust the beam range of the sensor (EE and HF models only):
 - Shut off the water and power supplies.
 - Remove the four screws from the top front.
 - To adjust sensing distance, use a mini-screwdriver (3.0mm flat tip or smaller) and rotate adjustment potentiometer screw on side of sensor. Turn clockwise to sense objects further away. This is represented by thicker end of curve on sensor label. The screw can be turned a maximum of 3/4 turns. The sensor has a maximum range of approximately 30". It is factory set at 15".
 - NOTE: Do not** turn adjustment as high as it can go. If you do the sensor will lock on until you turn the sensing distance back down.
 - There is an adjustable on-time delay of 0.5 seconds to prevent nuisance actuation of the solenoid valve should someone walk by. To adjust on-time delay, rotate blue knob on timer clockwise. The maximum on-time delay is 1 second. After drinking, the water will shut off immediately after walking away. Maximum run time is 30 seconds should someone tamper with the sensor. **NOTE:** Walls with a reflective finish, i.e., ceramic tile, across from the sensor may cause false actuation no matter what the sensor adjustment is for distance. Therefore, do not install the unit in such an area or dull the surface of the wall so it will not reflect light.

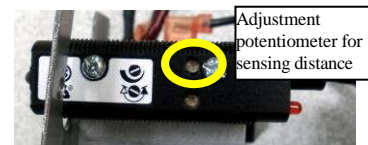

C. MAINTENANCE

The only maintenance operation required is the removal of dirt and lint from the condenser where used. Inspection should be made at 3-month intervals. Disconnect the power supply cord, then clean the condenser with a small stiff non-wire or vacuum cleaner attachment brush when required. Observance of this procedure will insure adequate air circulation through the condenser so operation is efficient and economical.

D. OVERLOAD PROTECTION

The compressor motor, where used, is equipped with an automatic reset protector which will disconnect the motor from the line in case of an overload.

E. LUBRICATION

This unit is equipped with a hermetically sealed compressor and requires no additional lubrication. The fan motor, where used, on this unit seldom needs oiling, but if required, a few drops of SAE 10 oil should be used.

F. TO DISCONTINUE USE OF WATER COOLER

- Close water shut-off valve.
- Provide container to catch water to be drained.
- On the push button model, disconnect the water supply line at the shut off valve and remove the tank drain plug. Actuate and hold in the pushbutton to open the solenoid valve and completely drain the cooler. Disconnect the power supply cord.
- On the EE model, disconnect the water supply line at the shut off valve and remove the tank drain plug. Actuate the solenoid, as explained in Step B8 to completely drain the cooler. Disconnect the power supply cord.
- Replace plug when draining is complete.
- ALWAYS DRAIN ALL WATER WHEN FREEZING TEMPERATURES ARE ANTICIPATED AND BEFORE SHIPPING THE WATER COOLER.**

*Americans With Disabilities Act

WARNING

The warranty and the Underwriters' Laboratory Listing for this machine are automatically voided if this machine is altered, modified, or combined with any other machine or device. Alteration or modification of this machine may cause serious flooding and/or hazardous electrical shock or fire. EXCEPT AS SET FORTH HEREIN, THE MANUFACTURER MAKES NO OTHER WARRANTY, GUARANTEE OR AGREEMENT EXPRESSED, IMPLIED OR STATUTORY, INCLUDING ANY IMPLIED WARRANTY OR MERCHANTABILITY OR FITNESS FOR A PARTICULAR PURPOSE.

OASIS INTERNATIONAL
222 East Campus View Blvd. • Columbus, OH 43235 U.S.A.
1-800-950-3226
www.oasiscoolers.com

OASIS® VERSACOOLER® II MODELS

PAC, PGAC, PFAC, P8AC, PG8AC, PF8AC, P8ACEE, PF8ACEE, PV8AC

SUNROC MODELS ADAAC, ADAFAC, ADA8AC, ADAF8AC, ADA8ACHF, ADAF8ACHF

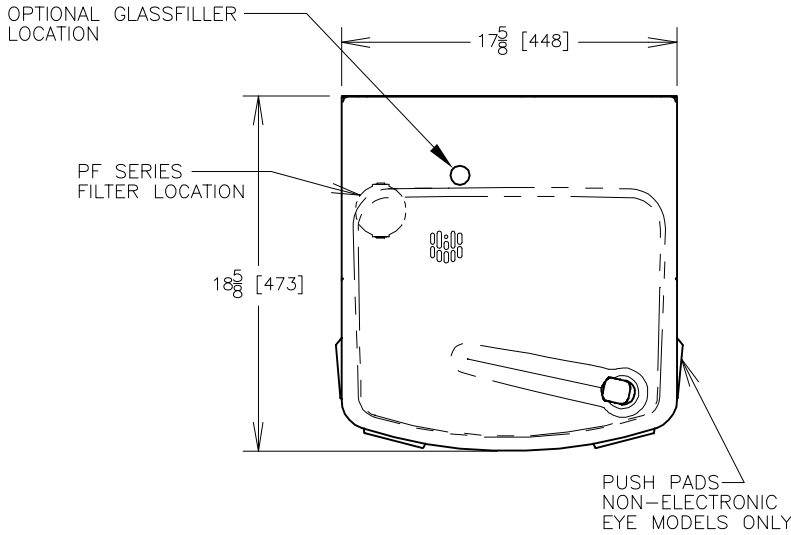

NOTES:

1. TRAP, STOP VALVE AND ELECTRICAL OUTLET NOT FURNISHED.
2. ALLOW 4 INCHES [102 MM] MIN. PER SIDE FOR VENTILATION.
- *3. RECOMMENDED ADULT BARRIER FREE HEIGHT INSTALLATION SHOWN. REDUCE HEIGHT BY 3 INCHES FOR INSTALLATIONS USED PRIMARILY BY CHILDREN AGES 12 AND YOUNGER. UNIT SHALL ALSO HAVE A MINIMUM CLEAR FLOOR SPACE 30[760] BY 48[1220]. ADJUST VERTICAL DIMENSIONS AS REQ'D TO COMPLY WITH FEDERAL, STATE, AND LOCAL CODES.
4. ALL DIMENSIONS ARE IN INCHES. DIMENSIONS IN BRACKETS [] ARE IN MILLIMETERS.

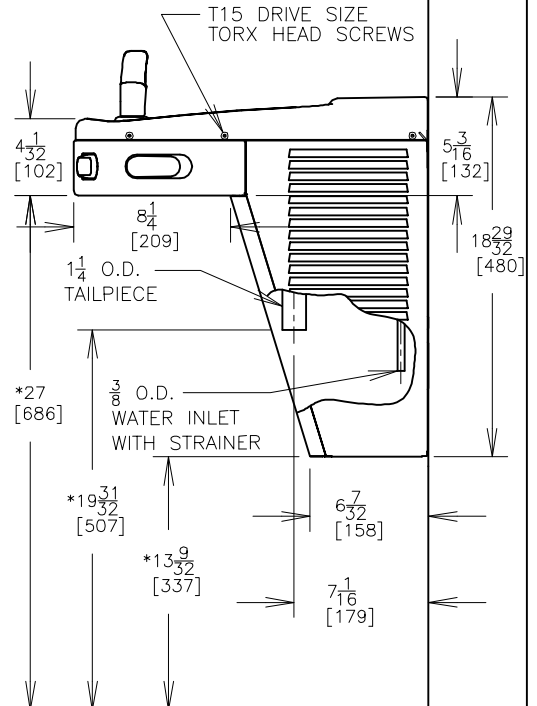
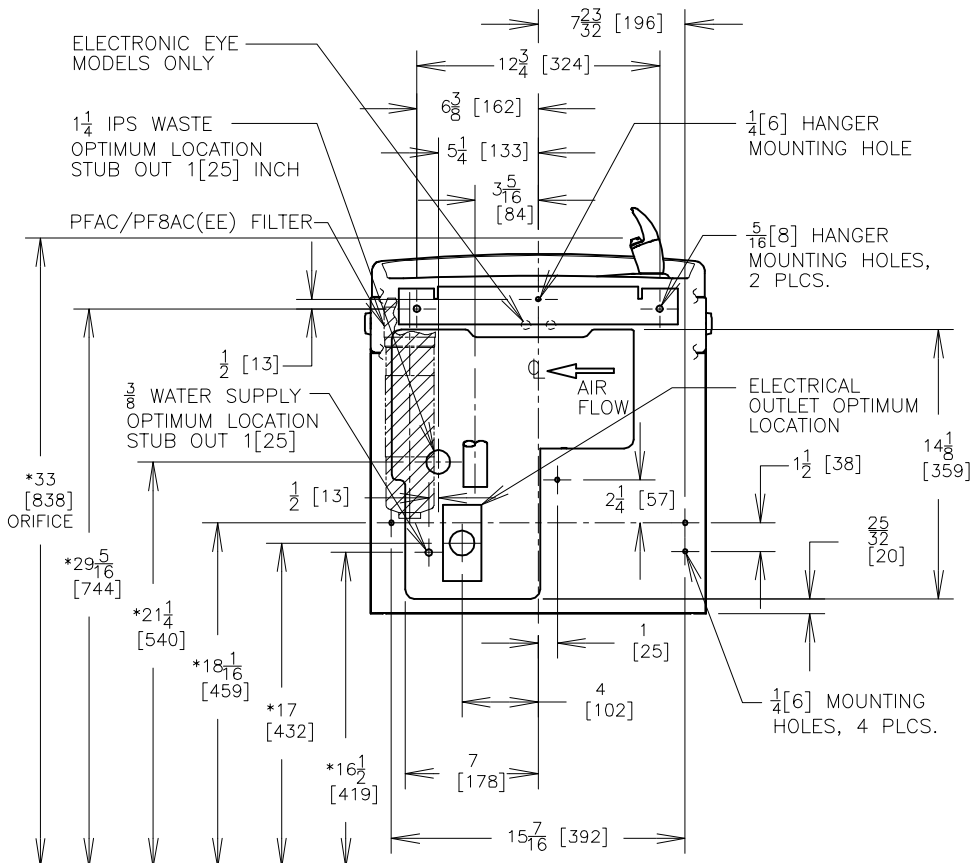
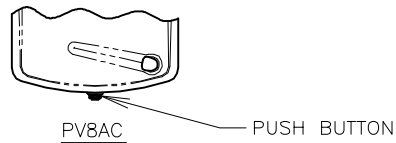

THIRD ANGLE PROJECTION

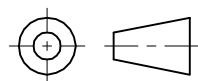

ROUGHING-IN AND DIMENSIONAL DRAWING

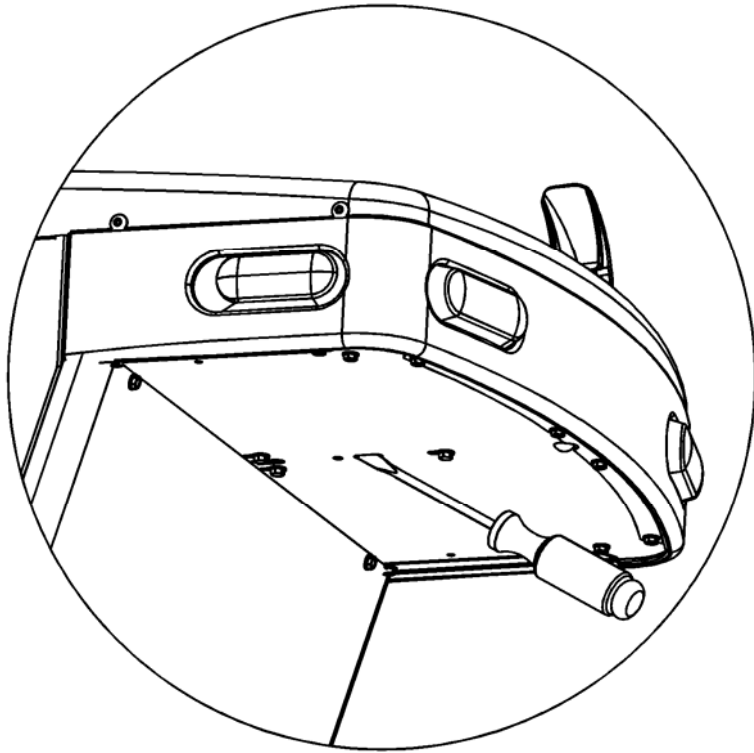

To adjust stream height, insert a 1/8" Flat blade screwdriver into the slotted hole as shown. The screwdriver will engage the stream height adjuster in the cartridge plunger. Turn clockwise to increase stream height, or ccw to reduce stream height.

032386-048 Rev. A

OASIS® VERSACOOLER® II MODELS PAC, PGAC, PFAC, P8AC, PG8AC, PF8AC, P8ACEE, PF8ACEE, PV8AC SUNROC MODELS ADAAC, ADAFAC, ADA8AC, ADAF8AC, ADA8ACHF, ADAF8ACHF

A. INSPECTION

Inspect the carton and water cooler for evidence of rough handling and concealed damage. Damage claims should be filed with the carrier.

B. TO PUT WATER COOLER INTO SERVICE

- Note:** The following states require a licensed plumber to install cooler; AR, GA, MA, MI, OK, RI, SC, SD, TX, VT and WI. CA, KS, MN, NM and OR allow for a state-registered installer or contractor as well. State and local plumbing codes may prohibit the use of saddle tapping valves for water line connection in some applications. All connections must conform to applicable plumbing codes.
- Locate and install plumbing and electrical service, if required, in accordance with the Roughing-in Drawing. Filter units have additional instructions on a label inside the access panel. Read these before installing unit. This drinking water cooler is designed to be operated at a water supply line pressure of up to 100 psi (690 kPa). A pressure regulator must be installed in front of the unit's water inlet if the water pressure (including any possible pressure spikes) could exceed 100 psi (690 kPa).
- FLUSH BUILDING WATER SUPPLY LINE BEFORE INSTALLING UNIT.
- Install unit on the wall hanger. **Wall hanger is shipped fastened to the back of the unit.**
- Install a trap in the waste line and a shut off valve in the water supply line.** An in-line strainer is furnished in the "Water Supply" tube. Connect the "Water Supply" tube to the shut off valve. This connection should not be a solder joint or flare connection to allow access to the strainer for service. To ease removal of the strainer, a sheet metal screw may be lightly threaded into the open end. When the unit has an internal waste trap, the trap should be wrapped with insulating tape to prevent sweating. Use of the 1-3/4 diameter knockout for a waste line is not recommended because of a potential conflict with ADA* toe space clearance requirements. Check your local building code inspector for approval.
- Rotate the fan blade by hand to see that it is free of obstructions.
- Check the available power supply against the water cooler data plate to assure correct electrical service. This drinking water cooler is intended to be connected to a 20A minimum ground fault circuit interrupting (GFCI) device to meet UL requirements. Plug power supply cord into wall outlet. The rear most 1-3/8 diameter knockout in the frame bottom is for an externally located electrical supply. Make sure the knockout hole edge is smooth and free of any burrs. Use of a Heyco bushing #2184 in the knocked out hole is recommended in order to prevent damage to the service cord and to close up excess opening around the cord. Route the cord so it does not interfere with ADA* space requirements.
- To fill the cold water tank on water cooler versions, open the water supply line shut-off and push any one of the front or side pushbuttons to allow water to flow to the bubbler. On the EE or HF model, actuate the solenoid by holding one hand approximately 3" from the infrared sensor. Run water until stream is free of bubbles.
- To Adjust Bubbler Stream:
 - All Pushbutton models are equipped with a Cartridge Regulator. The P8AC, PAC, PG8AC, PGAC, PF8AC, PFAC, ADAAC, ADAFAC, ADA8AC and ADAF8AC have a slot in the shelf below the Pushbuttons. Insert a screwdriver in this slot to adjust regulator. Turn adjustment clockwise to increase stream height. To access the PV8AC adjustment, remove the Bezel and Button from the front of the cooler.
 - Electric Eye (EE or HF) models have a Regulator built into the Bubbler. If adjustment is needed, insert a 5/64 hex wrench approximately 1-1/8" into the bubbler nozzle opening until it bottoms out and is seated in an adjust screw. Turn the adjust screw clockwise to reduce the stream height or counterclockwise to increase the height. Note, less than one turn is required to go from a closed to a wide open flow. Do not over tighten the adjuster in the closed position as stripping the hex impression in the adjust screw may result. Turn the adjuster 1/16 of a turn at a time.
- On electric eye equipped models, place and then hold hand approximately 3" from the sensor to actuate the solenoid valve. After approximately 30 seconds run time, the sensor will automatically shut off the solenoid valve. To reactivate, move hand away for an instant and then again place it in front of the sensor.
- To adjust the beam range of the sensor (EE and HF models only):
 - Shut off the water and power supplies.
 - Remove the four screws from the top front.
 - To adjust sensing distance, use a mini-screwdriver (3.0mm flat tip or smaller) and rotate adjustment potentiometer screw on side of sensor. Turn clockwise to sense objects further away. This is represented by thicker end of curve on sensor label. The screw can be turned a maximum of 3/4 turns. The sensor has a maximum range of approximately 30". It is factory set at 15".
 - NOTE: Do not** turn adjustment as high as it can go. If you do the sensor will lock on until you turn the sensing distance back down.
 - There is an adjustable on-time delay of 0.5 seconds to prevent nuisance actuation of the solenoid valve should someone walk by. To adjust on-time delay, rotate blue knob on timer clockwise. The maximum on-time delay is 1 second. After drinking, the water will shut off immediately after walking away. Maximum run time is 30 seconds should someone tamper with the sensor. **NOTE:** Walls with a reflective finish, i.e., ceramic tile, across from the sensor may cause false actuation no matter what the sensor adjustment is for distance. Therefore, do not install the unit in such an area or dull the surface of the wall so it will not reflect light.

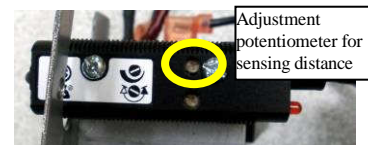

C. MAINTENANCE

The only maintenance operation required is the removal of dirt and lint from the condenser where used. Inspection should be made at 3-month intervals. Disconnect the power supply cord, then clean the condenser with a small stiff non-wire or vacuum cleaner attachment brush when required. Observance of this procedure will insure adequate air circulation through the condenser so operation is efficient and economical.

D. OVERLOAD PROTECTION

The compressor motor, where used, is equipped with an automatic reset protector which will disconnect the motor from the line in case of an overload.

E. LUBRICATION

This unit is equipped with a hermetically sealed compressor and requires no additional lubrication. The fan motor, where used, on this unit seldom needs oiling, but if required, a few drops of SAE 10 oil should be used.

F. TO DISCONTINUE USE OF WATER COOLER

- Close water shut-off valve.
- Provide container to catch water to be drained.
- On the push button model, disconnect the water supply line at the shut off valve and remove the tank drain plug. Actuate and hold in the pushbutton to open the solenoid valve and completely drain the cooler. Disconnect the power supply cord.
- On the EE model, disconnect the water supply line at the shut off valve and remove the tank drain plug. Actuate the solenoid, as explained in Step B8 to completely drain the cooler. Disconnect the power supply cord.
- Replace plug when draining is complete.
- ALWAYS DRAIN ALL WATER WHEN FREEZING TEMPERATURES ARE ANTICIPATED AND BEFORE SHIPPING THE WATER COOLER.**

*Americans With Disabilities Act

WARNING

The warranty and the Underwriters' Laboratory Listing for this machine are automatically voided if this machine is altered, modified, or combined with any other machine or device. Alteration or modification of this machine may cause serious flooding and/or hazardous electrical shock or fire. EXCEPT AS SET FORTH HEREIN, THE MANUFACTURER MAKES NO OTHER WARRANTY, GUARANTEE OR AGREEMENT EXPRESSED, IMPLIED OR STATUTORY, INCLUDING ANY IMPLIED WARRANTY OR MERCHANTABILITY OR FITNESS FOR A PARTICULAR PURPOSE.

OASIS INTERNATIONAL
222 East Campus View Blvd. • Columbus, OH 43235 U.S.A.
1-800-950-3226
www.oasiscoolers.com

OASIS® VERSACOOLER® II MODELS

PAC, PGAC, PFAC, P8AC, PG8AC, PF8AC, P8ACEE, PF8ACEE, PV8AC

SUNROC MODELS ADAAC, ADAFAC, ADA8AC, ADAF8AC, ADA8ACHF, ADAF8ACHF

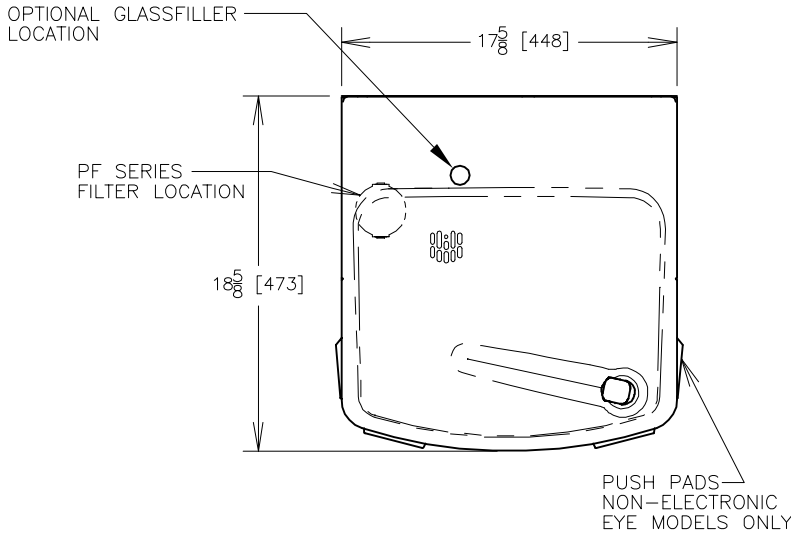

NOTES:

1. TRAP, STOP VALVE AND ELECTRICAL OUTLET NOT FURNISHED.
2. ALLOW 4 INCHES [102 MM] MIN. PER SIDE FOR VENTILATION.
- *3. RECOMMENDED ADULT BARRIER FREE HEIGHT INSTALLATION SHOWN. REDUCE HEIGHT BY 3 INCHES FOR INSTALLATIONS USED PRIMARILY BY CHILDREN AGES 12 AND YOUNGER. UNIT SHALL ALSO HAVE A MINIMUM CLEAR FLOOR SPACE 30[760] BY 48[1220]. ADJUST VERTICAL DIMENSIONS AS REQ'D TO COMPLY WITH FEDERAL, STATE, AND LOCAL CODES.
4. ALL DIMENSIONS ARE IN INCHES. DIMENSIONS IN BRACKETS [] ARE IN MILLIMETERS.

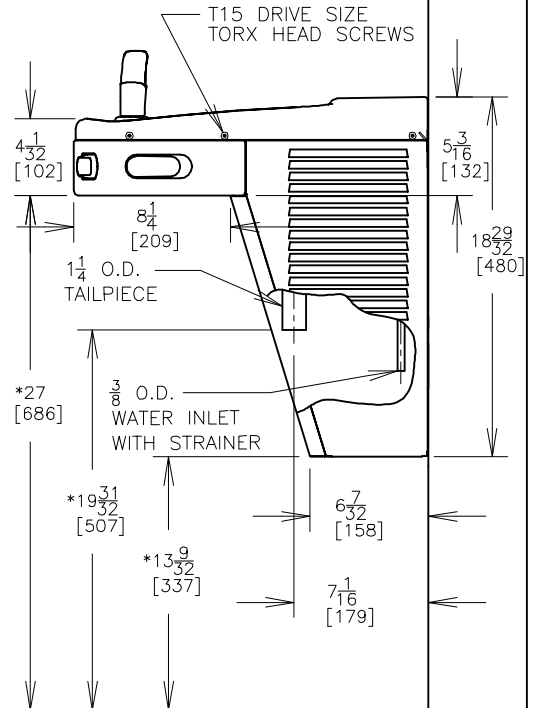
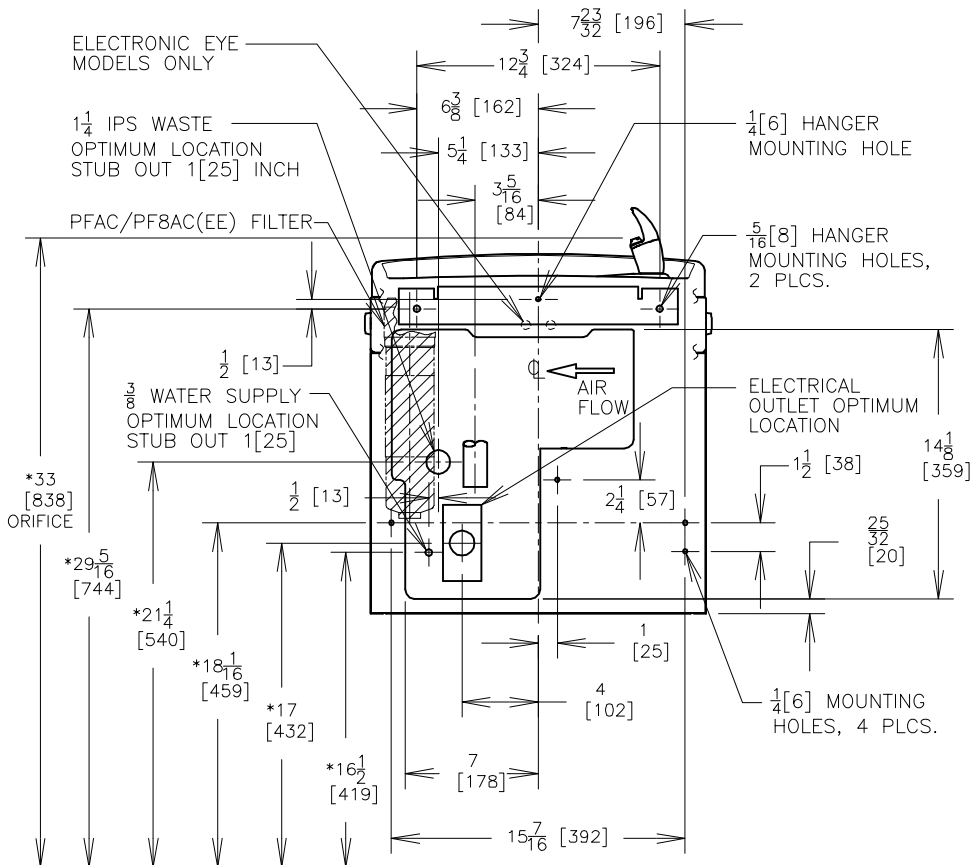
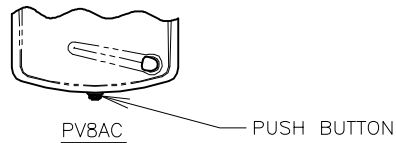

THIRD ANGLE PROJECTION

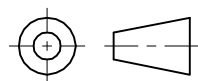

ROUGHING-IN AND DIMENSIONAL DRAWING