

Sink Machines



55808

POWERCLEAR® MACHINE

- 3/4" to 1 1/2" (20 mm to 12.6 mm) Drain Lines.
- AUTOFEED® Technology – Keeps your hands clean and free from touching the cable while advancing and retrieving.
- Heavy-Duty Inner Core Cable – For long life, increased strength and kink resistance.
- Clear Cover – Allows user to view how much cable is remaining.
- Two-Piece Guide Hose – Use one piece for close applications and extension for areas where access is limited.
- Easy Pull Drain Plug – Drain access water after each use to extend cable life.
- Guide Hose – Helps keep work area clean.

Catalog No.	Model No.	Description	Cable Diameter		Cable Length		Voltage	Weight	
			in	mm	ft	m	V	lb	kg
55808	PowerClear	Drain Cleaning Machine	-	-	-	-	100 - 120V, 50/60 Hz	12	5.4
55983		1/4" - 30' Replacement Cable	1/4	6	30	9	-	5.3	2.4



71702

K-40 SINK MACHINE

- 3/4" to 2 1/2" (20 mm to 75 mm) Drain Lines.
- The Model K-40 Sink Machine is ideal for cleaning small secondary drain lines.
- 1/4" (6 mm) cables best for 3/4" to 1 1/2" (20 mm to 40 mm) lines.
- 5/16" (8 mm) cables best for 3/4" to 1 1/2" (20 mm to 40 mm) lines.
- 3/8" (10 mm) cables best for 1 1/4" to 2 1/2" (40 mm to 75 mm) lines.
- The K-40 sits flat on the floor or countertop and also tips onto its back for easy access to sink drains and bathtubs full of water. It practically eliminates jobsite cleanup thanks to the patented guide hose two-way AUTOFEED® control. It completely contains the rotating cable and eliminates any waste water splashing or spraying.
- 1/8 HP induction motor quietly delivers enough torque to clear even the toughest blockages.
- Premium-quality, compression-wound inner core cable combines strength and flexibility to resist kinking.
- Two-piece "twist lock" drum housing will not dent or corrode and allows easy access to the inner drum and cable.
- Special inner drum design reduces cable flip-over inside the drum and drum leakage.
- Two-way AUTOFEED control advances and retrieves the drain cleaning cable with a simple push of a lever keeping you and the work area clean.
- Includes RIDGID drain cleaning gloves and operator's manual.



71722

Catalog No.	Model No.	Description	Voltage	Weight	
			V	lb	kg
71702	K-40	Machine with: C-131C, 5/16" x 35' (8 mm x 10.7 m) Cable with Inner Drum	120V, 60 Hz	29	13.0
71722	K-40 AF	Machine with: AUTOFEED, Guide Hose, Mounting Bracket, C-131C SB, 5/16" x 35' (8 mm x 10.7 m) Speed Bump Cable with Inner Drum	120V, 60 Hz	33	15.0
71732			220 - 240V, 50/60 Hz		

Standard Equipment

Catalog No.	Description	71702 K-40 120V	71722 K-40 AF 120V	71732 K-40 AF 220 - 240V
56792	5/16" (8 mm) x 35' (10.7 m) Inner Core with Bulb Auger	•		
95847	5/16" (8 mm) x 35' (10.7 m) Inner Core Speed Bump with Bulb Auger		•	•



Cables

	Catalog No.	Model No.	Description	Weight	
				lb	kg
	50647	S-1	1/4" (6 mm) x 15' (4,6 m) with Funnel Auger	2 1/4	1.0
	50652	S-2	1/4" (6 mm) x 25' (7,6 m) with Funnel Auger	3 1/2	
	50657	S-3	1/4" (6 mm) x 35' (10,7 m) with Funnel Auger	5	
	62225	C-1	5/16" (8 mm) x 25' (7,6 m) with Bulb Auger	3 1/2	2.0
	56782	C-11C	5/16" (8 mm) x 25' (7,6 m) Inner Core with Bulb Auger	4	
	89400	C-21	5/16" (8 mm) x 50' (15,2 m) with Bulb Auger	7	3.0
	56792	C-131C	5/16" x 35' (8 mm x 10,7 m) Inner Core with Bulb Auger	5 1/2	
	95847	C-131CSB	5/16" x 35' (8 mm x 10,7 m) Inner Core Speed Bump with Bulb Auger	5 1/2	2.0
	62235	C-2	5/16" (8 mm) x 25' (7,6 m) with Drop Head Auger	3 1/2	
	56787	C-21C	5/16" (8 mm) x 25' (7,6 m) Inner Core with Drop Head Auger	4	
	89405	C-22	5/16" (8 mm) x 50' (15,2 m) with Drop Head Auger	7	3.0
	56797	C-231C	5/16" (8 mm) x 35' (10,7 m) Inner Core with Drop Head Auger	5 1/2	2.0
	62245	C-4	3/8" (10 mm) x 25' (7,6 m) with Male Coupling	4 1/2	
	62250	C-5	3/8" (10 mm) x 35' (10,7 m) with Bulb Auger	8 1/4	4.0
	62260	C-6	3/8" (10 mm) x 35' (10,7 m) with Male Coupling	8 1/4	4.0
	96037	C-61C	3/8" (10 mm) x 35' (10,7 m) Inner Core with Male Coupling	8 1/2	

Tools

	Catalog No.	Model No.	Description	Replac. Blade(s)
	62990	T-201	Straight Auger, 5" (125 mm) Long	-
	62995	T-202	Bulb Auger, 1 1/8" (29 mm) O.D.	-
	63000	T-203	Bulb Auger 7/8" (22 mm) O.D.	-
	54837	T-204	"C" Cutter 1" (25 mm)	54832
	63005	T-205	"C" Cutter, 1 3/8" (35 mm)	97835
	63010	T-206	Funnel Auger, 3" (80 mm) Long	-
	63030	T-210	Spade Cutter, 1" (25 mm)	97905
	63035	T-211	Spade Cutter, 1 3/8" (35 mm)	97825
	63040	T-212	Spade Cutter, 1 3/4" (45 mm)	92850
	63045	T-213	4-Blade Cutter, 1" (25 mm)	97795
	63050	T-214	4-Blade Cutter, 1 3/8" (35 mm)	97910
	63055	T-215	4-Blade Cutter, 1 3/4" (45 mm)	97915
	63065	T-217	Drop Head Auger, 4" (110 mm) Long	-
	55457	T-225	Retrieving Auger	-
	48482	T-250	Tool Set includes: T-203, T-205, T-210, T-217, A-13	-
	52812	T-230	H-D "C" Cutter, 2" (50 mm)	92815
	52817R	T-231	H-D "C" Cutter, 2 1/2" (65 mm)	92820
	52822	T-232	H-D "C" Cutter, 3" (80 mm)	92835
	59230	A-13	3/8" Cable Pin Key	-

Accessories

	Catalog No.	Model No.	Description
	26558	A-40AF	AUTOFEED Assembly & Guide Hose for K-40 Includes Mounting Bracket
	23913	A-39AF	Replacement AUTOFEED Cartridge
	71757	A-40G	A-40G Guide Hose Assembly
	72702	A-40B	Mounting Bracket
	71847	-	Cable Torque Arm
	68917		Drum Liner
	76597		Top Roller Bearing Housing Assy
	76817		C-6 Cable Kit incl. Inner Drum, C-6 Cable Torque Arm, T-250 Tool Set
	98072		C-61C Cable Kit including: Inner Drum, C-61C Cable, Torque Arm, T-250 Tool Set
	41937	-	RIDGID Leather Drain Cleaning Gloves
	70032	-	RIDGID PVC Drain Cleaning Gloves

Sink Machines



K-45 SINK MACHINE

- 3/4" to 2 1/2" (20 mm to 75 mm) Drain Lines.
- 1/4" (6 mm) cables best for 3/4" to 1 1/2" (20 mm to 40 mm) lines.
- 5/16" (8 mm) cables best for 3/4" to 1 1/2" (20 mm to 40 mm) lines.
- 3/8" (10 mm) cables best for 1 1/4" to 2 1/2" (30 mm to 75 mm) lines.
- Excellent for small line cleaning. Opens clogged lavatory, sink lines, urinals and tub or shower drains.
- Advanced two-way AUTOFEED® control keeps hands and work area clean – advances & retrieves cable with push of a lever.
- Manual version has a slide-action chuck for quick locking/releasing of cable (Not available in Europe).
- Lightweight, easy-to-use, no setup required.
- Variable speed power unit rotates cable 0-600 RPMs.
- Two-piece twist lock canister with interchangeable inner drum – Makes cable change-out simple; easy to match the right cable for the job.
- Inner drum prevents water leaks and greatly reduces cable flip-over inside the drum.
- Drums won't rust or dent-ever.
- Drum Capacity: 50' of 5/16" (15 m of 8 mm) or 35' of 3/8" (11 m of 10 mm).
- Includes RIDGID drain cleaning gloves and operator's manual.



35473



36018

INNER CORE CABLES

(MODELS C-11C, C-61C, C-131C, C-21C, C-231C)

- Vinyl-wrapped inner core to prevent core from rusting to spring – enhances cable life.
- Compression wound for strength.
- Resists kinking and negotiates tough bends and traps.
- Provides good flexibility and cleaning power to the cable end.

	Catalog No.	Model No.	Description	Voltage		Weight	
				V	Hz	lb	kg
K-45AF	35473	K-45AF	Machine with Gloves: - C-11C, 5/16" x 25' (8 mm x 7.6 m) Inner Core Cable with Inner Drum	110 - 120V, 50/60 Hz	11	5.0	
	36033		Machine with Gloves: - C-11C, 5/16" x 25' (8 mm x 7.6 m) Inner Core Cable with Inner Drum	220 - 240V, 50/60 Hz	13.8	6.5	
	35998	K-45AF-1	Same as Model No. K-45AF plus Gloves: C-6429 Carrying Case	110 - 120V, 50/60 Hz	27	12.2	
	36038			220 - 240V, 50/60 Hz			
	36003			110 - 120V, 50/60 Hz			
	36043	K-45AF-5	Machine with Gloves: - C-11C, 5/16" x 25' (8 mm x 7.6 m) Inner Core Cable with Inner Drum - C-6, 3/8" x 35' (10 mm x 10.7 m) Cable with Inner Drum - T-250, Five -Piece Tool Set for 3/8" (10 mm) Cable - C-6429 Carrying Case	110 - 120V, 50/60 Hz	34	15.4	
	36043	K-45AF-7	Machine with Gloves: - C-11C, 5/16" x 25' (8 mm x 7.6 m) Inner Core Cable with Inner Drum - C-6, 3/8" (10 mm) x 25' (10.7 m) Cable with Inner Drum - T-250, Five-Piece Tool Set for 3/8" (10 mm) Cable - C-6429 Carrying Case	220 - 240V, 50/60 Hz			
36008	Machine with Gloves: - C-11C, 5/16" x 25' (8 mm x 7.6 m) Inner Core Cable w/Inner Drum - C-6, 3/8" x 35' (10 mm x 10.7 m) Cable with Inner Drum - C-21, 5/16" x 50' (8 mm x 15.2 m) Cable with Inner Drum - T-250, Five-Piece Tool Set for 3/8" (10 mm) Cable - C-6429 Carrying Case		110 - 120V, 50/60 Hz	42	19.0		
K-45	36018	K-45	Machine with Gloves: - C-11C, 5/16" x 25' (8 mm x 7.6 m) Inner Core Cable with Inner Drum	110 - 120V, 50/60 Hz	11	5.0	
	36048			220 - 240V, 50/60 Hz			
	36013	K-45-1	Same as Model No. K-45 plus Gloves: C-6429 Carrying Case	110 - 120V	27	12.2	
	36053			220 - 240V, 50/60 Hz			
	36023			110 - 120V			
	36058	K-45	Machine with Gloves: - C-11C, 5/16" x 25' (8 mm x 7.6 m) Inner Core Cable with Inner Drum - C-6, 3/8" x 35' (10 mm x 10.7 m) Cable with Inner Drum - T-250, Five -Piece Tool Set for 3/8" (10 mm) Cable - C-6429 Carrying Case	220 - 240V, 50/60 Hz	34	15.4	
	36028	K-45-7	Machine with Gloves: - C-11C, 5/16" x 25' (8 mm x 7.6 m) Inner Core Cable with Inner Drum - C-6, 3/8" x 35' (10 mm x 10.7 m) Cable Inner Drum - C-21, 5/16" x 50' (8 mm x 15.2 m) Cable with Inner Drum - T-250, Five -Piece Tool Set for 3/8" (10 mm) Cable - C-6429 Carrying Case	110 - 120V, 50/60 Hz	42	19.0	

Standard Equipment

Catalog No.	Description	35473 K-45AF	36033 K-45AF	35998 K-45AF-1	36038 K-45AF-1	36003 K-45AF-5	36043 K-45AF-5	36008 K-45AF-7	36018 K-45	36048 K-45	36013 K-45-1	36053 -	36023 K-45-5	36058 K-45	36028 K-45AF-7
56782	5/16" (8 mm) x 25' (7.6 m) Inner Core with Bulb Auger	•	•	•	•	•	•	•	•	•	•	•	•	•	•
89410	Carrying Case			•	•	•	•	•			•	•	•	•	•
48482	Tool Set includes: T-203, T-205, T-210, T-217, A-13					•	•	•					•	•	•
62260	3/8" (10 mm) x 35' (10.7 m) with Male Coupling					•	•	•					•	•	•
89400	5/16" (8 mm) x 50' (15.2 m) with Bulb Auger							•							•



Cables

	Catalog No.	Model No.	Description	Weight	
				lb	kg
1/4" - 6 mm	50647	S-1	1/4" (6 mm) x 15' (4,6 m) with Funnel Auger	2 1/4	1.0
	50652	S-2	1/4" (6 mm) x 25' (7,6 m) with Funnel Auger	3 1/2	1.6
	50657	S-3	1/4" (6 mm) x 35' (10,7 m) with Funnel Auger	5	2.2
5/16" - 8 mm	62225	C-1	5/16" (8 mm) x 25' (7,6 m) with Bulb Auger	3 1/2	1.6
	56782	C-1IC	5/16" (8 mm) x 25' (7,6 m) Inner Core with Bulb Auger	4	1.8
	89400	C-21	5/16" (8 mm) x 50' (15,2 m) with Bulb Auger	7	3.2
	56792	C-13IC	5/16" x 35' (8 mm x 10,7 m) Inner Core with Bulb Auger	5 1/2	2.5
	62235	C-2	5/16" (8 mm) x 25' (7,6 m) with Drop Head Auger	3 1/2	1.6
	56787	C-2IC	5/16" (8 mm) x 25' (7,6 m) Inner Core with Drop Head Auger	4	1.8
	89405	C-22	5/16" (8 mm) x 50' (15,2 m) with Drop Head Auger	7	3.2
	56797	C-23IC	5/16" (8 mm) x 35' (10,7 m) Inner Core with Drop Head Auger	5 1/2	2.5
	62245	C-4	3/8" (10 mm) x 25' (7,6 m) with Male Coupling	4 1/2	2.0
3/8" - 10 mm	62250	C-5	3/8" (10 mm) x 35' (10,7 m) with Bulb Auger	8 1/4	3.8
	62260	C-6	3/8" (10 mm) x 35' (10,7 m) with Male Coupling	8 1/4	3.8
	96037	C-6IC	3/8" (10 mm) x 35' (10,7 m) Inner Core with Male Coupling	8 1/2	4.0

Tools – Fits C-4, C-6 and C-6IC Cables

	Catalog No.	Model No.	Description	Replac. Blade(s)
	62990	T-201	Straight Auger, 5" (125 mm) Long	-
	62995	T-202	Bulb Auger, 1 1/8" (29 mm) O.D.	-
	63000	T-203	Bulb Auger 7/8" (22 mm) O.D.	-
	54837	T-204	"C" Cutter 1" (25 mm)	54832
	63005	T-205	"C" Cutter, 1 3/8" (35 mm)	97835
	63010	T-206	Funnel Auger, 3" (80 mm) Long	-
	63030	T-210	Spade Cutter, 1" (25 mm)	97905
	63035	T-211	Spade Cutter, 1 3/8" (35 mm)	97825
	63040	T-212	Spade Cutter, 1 3/4" (45 mm)	92850
	63045	T-213	4-Blade Cutter, 1" (25 mm)	97795
	63050	T-214	4-Blade Cutter, 1 3/8" (35 mm)	97910
	63055	T-215	4-Blade Cutter, 1 3/4" (45 mm)	97915
	63065	T-217	Drop Head Auger, 4" (110 mm) Long	-
	55457	T-225	Retrieving Auger	-
	52812	T-230	H-D "C" Cutter, 2" (50 mm)	92815
	52817R	T-231	H-D "C" Cutter, 2 1/2" (65 mm)	92820
	52822	T-232	H-D "C" Cutter, 3" (80 mm)	92835
	48482	T-250	Tool Set includes: T-203, T-205, T-210, T-217, A-13	-
	59230	A-13	3/8" Cable Pin Key	-

Accessories

Catalog No.	Model No.	Description
68917	-	Drum Liner
89410	C-6429	Carrying Case
76817	-	C-6 Cable Kit incl. Inner Drum, C-6 Cable Torque Arm, T-250 Tool Set
98072	-	C-6IC Cable Kit including: Inner Drum, C-6IC Cable, Torque Arm, T-250 Tool Set
23908	A-39AF	Drum Front and AUTOFEED Assembly
23913	-	Replacement AUTOFEED Cartridge
41937	-	RIDGID Leather Drain Cleaning Gloves
70032	-	RIDGID PVC Drain Cleaning Gloves

Drum Machines



53107

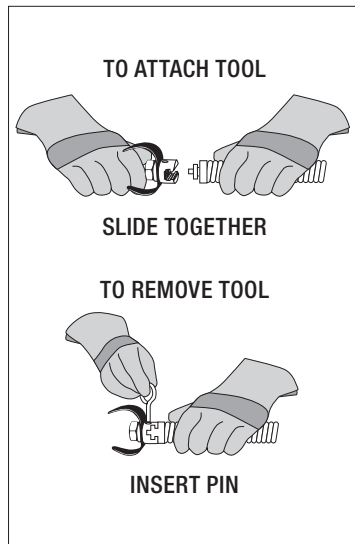

For C-4, C-6, C-6IC, C-7, C-8, C-9, C-10, C-11, C-12, C-14, C-15, C-31, C-32, C-33, C-44, C-45, and C-46 & all IW Cables.

K-3800 DRUM MACHINE

- 3/4" (20 mm) to 4" (110 mm) Drain Lines.
- A powerful, easy to transport, versatile machine for cleaning indoor drains. Requires minimal set-up to clean sink lines, floor drains and roof vents.
- Rugged, corrosion-resistant molded cable drum won't dent or rust. The drum tilt adjusts for proper cable feed angle. Inner-drum guards against cable flip-over inside the drum.
- Cable drum quick-release and built-in hand-holds allow easy cable change and transport.
- Maximum drum capacity is 100' (30,5 m) of 3/8" (10 mm) or 90' (27 m) of 1/2" (12 mm) continuous length cable.
- 3/8" (10 mm) cable best for 1 1/2" (40 mm) to 3" (75 mm) lines up to 100' (30,5 m).
- 1/2" (12 mm) cable best for 2" (50 mm) to 4" (110 mm) lines up to 90' (27 m).
- Optional sink drum holds up to 50' (15 m) of 5/16" (8 mm) or 1/4" (6 mm) cable.
- Ideal for cleaning through 3/4" (20 mm) to 1 1/2" (40 mm) sink traps.
- Powerful 1/10 HP universal motor spins cable at 220 RPM. When cable hits blockage, motor gears down automatically to deliver more power and enhance operator control.
- Tools connect to cable in seconds.
- Optional heavy duty AUTOFEED® system.
- Includes RIDGID leather drain cleaning gloves and operator's manual.

Machine Options

Catalog No.	Model No.	Description	Voltage		Weight	
			V	lb	kg	
53107	K-3800	Machine with Gloves	120V, 50/60Hz	42	19.0	
53112	K-3800 with C-31	Machine with Std. Equip: C-31, 3/8" x 50' (10 mm x 15.2 m) Cable, T-202 Bulb Auger, T-205 "C" Cutter, T-211 Spade Cutter, A-13 Pin Key, Pair of Gloves	120V, 50/60Hz	65	29.2	
53117	K-3800 with C-32	Machine with Std. Equip: C-32, 3/8" x 75' (10 mm x 22.8.2 m) Cable, T-202 Bulb Auger, T-205 "C" Cutter, T-211 Spade Cutter, A-13 Pin Key, Pair of Gloves	120V, 50/60Hz	71	32.2	
53122	K-3800 with C-45	Machine with Std. Equip: C-45, 1/2" x 75' (12 mm x 22.8 m) Cable, T-102 Funnel Auger, T-142 Knife Blade Cutter, T-107 Spade Cutter, A-12 Pin Key, Pair of Gloves	120V, 50/60Hz	83	37.7	
53127	K-3800 with C-46	Machine with Std. Equip: C-46, 1/2" x 90' (12 mm x 27.4 m) Cable, T-102 Funnel Auger, T-142 Knife Blade Cutter, T-107 Spade Cutter, A-12 Pin Key, Pair of Gloves	120V, 50/60Hz	91	41.3	
59462	K-3800	Machine with Gloves	220 - 240V, 50/60 Hz	42	19.0	
63822	K-3800 with C-45	Machine with Std. Equip: C-45, 1/2" x 75' (12 mm x 22.8 m) Cable, T-102 Funnel Auger, T-142 Knife Blade Cutter, T-107 Spade Cutter, A-12 Pin Key, Pair of Gloves	220 - 240V, 50/60 Hz	83	37.7	
63827	K-3800 with C-32	Machine with Std. Equip: C-32, 3/8" x 75' (10 mm x 22.8 m) Cable, T-202 Bulb Auger, T-205 "C" Cutter, T-211 Spade Cutter, A-13 Pin Key, Pair of Gloves	220 - 240V, 50/60 Hz	71	32.2	

Standard Equipment

Catalog No.	Description	53107 K-3800	53112 K-3800 w/C-31	53117 K-3800 w/C-32	53122 K-3800 w/C-45	53127 K-3800 w/C-46	59462 K-3800	63822 K-3800 w/C-45	63827 K-3800 w/C-32
41937	RIDGID Leather Drain Cleaning Gloves	•	•	•	•	•	•	•	•
37842	3/8" (10 mm) x 50' (15m) IC Cable		•						
49002	Tool Set [3/8" (10 mm) - K-400] Includes: - T-202 Bulb Auger - T-205 "C" Cutter - T-211 Spade Cutter - A-13 Pin Key		•	•					•
37862	1/2" (12 mm) x 75' (23 m) IC Cable				•			•	
54992	Tool Set: - T-102 Funnel Auger - T-142 Knife Blade Cutter - T-107 Spade Cutter - A-12 Pin Key				•	•		•	
55467	1/2" (12 mm) x 90' (28m) IC Cable					•			
37847	3/8" (10 mm) x 75' (23 m) IC Cable			•					•

Inner Core (IC) Cables

	Catalog No.	Model No.	Description	Weight	
				lb	kg
3/8" - 10 mm	37842	C-31	3/8" (10 mm) x 50' (15 m) IC Cable	18	8.2
	37847	C-32	3/8" (10 mm) x 75' (23 m) IC Cable	26	11.8
	37852	C-33	3/8" (10 mm) x 100' (30 m) IC Cable	34	15.4
	51752	T-122	Repair End, 3/8" (10 mm)	1	0.5
1/2" - 12 mm	37857	C-44	1/2" (12 mm) x 50' (15 m) IC Cable	27	12.2
	37862	C-45	1/2" (12 mm) x 75' (23 m) IC Cable	39	17.7
	37867	C-45HC	1/2" (12 mm) x 75' (23 m) Hollow Core Cable	38	17.2
	55467	C-46	1/2" (12 mm) x 90' (28 m) IC Cable	47	21.2
	59917	T-121	Repair End, 1/2" (12 mm)	3/4	0.8

Integrated Wound (IW) Cables

	Catalog No.	Model No.	Description	Weight	
				lb	kg
3/8" - 10 mm	87577	C-31IW	3/8" (10 mm) x 50' (15 m) IW Cable	18	8.2
	87582	C-32IW	3/8" (10 mm) x 75' (23 m) IW Cable	26	11.8
	87587	C-33IW	3/8" (10 mm) x 100' (30 m) IW Cable	34	15.4
	91037		Repair End for 3/8" (10 mm) IW Cable	1/2	0.2
1/2" - 12 mm	87592	C-44IW	1/2" (12 mm) x 50' (15 m) IW Cable	18	8.2
	87597	C-45IW	1/2" (12 mm) x 75' (23 m) IW Cable	26	11.8
	91042		Repair End for 1/2" (12 mm) IW Cable	3/8	0.3

Sink Drum Cables

	Catalog No.	Model No.	Description	Weight	
				lb	kg
1/4" - 6 mm	50652	S-2	1/4" (6 mm) x 25' (7.6 m) with Funnel Auger	3 1/2	1.6
	50657	S-3	1/4" (6 mm) x 35' (10.7 m) with Funnel Auger	5	2.2
5/16" - 8 mm	56782	C-11C	5/16" (8 mm) x 25' (7.6 m) Inner Core with Bulb Auger	4	1.8
	56792	C-131C	5/16" x 35' (8 mm x 10.7 m) Inner Core with Bulb Auger	5 1/2	2.5
	56787	C-21C	5/16" (8 mm) x 25' (7.6 m) Inner Core with Drop Head Auger	4	1.8
	56797	C-231C	5/16" (8 mm) x 35' (10.7 m) Inner Core with Drop Head Auger	5 1/2	2.5

Accessories

	Catalog No.	Model No.	Description	Weight	
				lb	kg
	55002	A-380	Standard Drum Assembly	12 1/2	5.6
	55007	A-381	Sink Drum Assembly		
	55012	A-381-A	Sink Drum with 25' (7.6 m) x 5/16" (8 mm) IC Cable w/Bulb Head	16 1/2	7.5
	41937		RIDGID Leather Drain Cleaning Gloves	1/2	0.2
	70032		RIDGID PVC Drain Cleaning Gloves		
	59230	A-13	3/8" Cable Pin Key	3 1/2	1.6
	59225	A-12	1/2" Cable Pin Key		
	55017		Transport Cart	18	8.2
	60087	A3800 PF	AUTOFEED® Assembly	7 3/8	3.3
	62412		Guide Hose Adapter for Sink Drum	3 1/2	1.6

Tools Fit 3/8" (10 mm) IC, 3/8" (10 mm) IW and 1/2" (12 mm) IW Cables

	Catalog No.	Model No.	Description	Replac. Blade(s)
	62990	T-201	Straight Auger, 5" (125 mm) Long	
	62995	T-202	Bulb Auger, 1 1/8" (29 mm) O.D.	-
	63000	T-203	Bulb Auger 7/8" (22 mm) O.D.	
	54837	T-204	"C" Cutter 1" (25 mm)	54832
	63005	T-205	"C" Cutter, 1 3/8" (35 mm)	97835
	52812	T-230	H-D "C" Cutter, 2" (50 mm)	92815
	52817R	T-231	H-D "C" Cutter, 2 1/2" (65 mm)	92820
	52822	T-232	H-D "C" Cutter, 3" (80 mm)	92835
	63010	T-206	Funnel Auger, 3" (80 mm) Long	-
	63015	T-207	Spiral Cutter, 1 1/4" (32 mm)	97840
	63020	T-208	Spiral Cutter, 1 1/2" (40 mm)	97895
	63025	T-209	Spiral Cutter, 2" (50 mm)	97900
	63030	T-210	Spade Cutter, 1" (25 mm)	97905
	63035	T-211	Spade Cutter, 1 3/8" (35 mm)	97825
	63040	T-212	Spade Cutter, 1 3/4" (45 mm)	92850
	63045	T-213	4-Blade Cutter, 1" (25 mm)	97795
	63050	T-214	4-Blade Cutter, 1 3/8" (35 mm)	97910
	63055	T-215	4-Blade Cutter, 1 3/4" (45 mm)	97915
	63060	T-216	Chain Knocker, 2" (50 mm)	98000
	63065	T-217	Drop Head Auger, 4" (110 mm) Long	
	55457	T-225	Retrieving Auger	
	12128	T-240	Tool Set (3/8"- K-380): T-202 Bulb Auger, T-211 Spade Cutter, A-13 Pin Key	-
	49002	T-260	Tool Set (3/8" (10 mm) - K-400) Includes: - T-202 Bulb Auger - T-205 "C" Cutter - T-211 Spade Cutter - A-13 Pin Key	-

Tools Fit 1/2" (12mm) IC Cables

	Catalog No.	Model No.	Description	Replac. Blade(s)
	62850	T-101	Straight Auger	
	62855	T-102	Funnel Auger	-
	62865	T-104	"H" Cutter, 2 1/2" (65 mm)	97800
	62870	T-105	Grease Cutter, 2 1/2" (65 mm)	97920
	62875	T-106	Grease Cutter, 3 1/2" (87 mm)	97925
	62880	T-107	Spade Cutter, 1 3/4" (45 mm)	92850
	62930	T-112	4-Blade Cutter, 1 3/4" (45 mm)	97915
	62935	T-113	4-Blade Cutter, 3" (75 mm)	97910
	62940	T-114	Chain Knocker for 4" lines	97985
	27642	T-125	Straight Retrieving Auger	-
	54842	T-141	Knife Blade Cutter 1 1/2" (40 mm)	54847
	54852R	T-142	Knife Blade Cutter 2 1/2" (65 mm)	97800
	54992	T-270	Tool Set: - T-102 Funnel Auger - T-142 Knife Blade Cutter - T-107 Spade Cutter - A-12 Pin Key	-
	92687		Drop Head Tool Adaptor 1/2" (12 mm)	

Drum Machines



93557

K-6200 DRUM MACHINE

- 3" to 6" (75 to 150 mm) Drain/Sewer Lines up to 200' (61 m).
- K-6200 machines offer superior maneuverability and a small footprint allows easy access to tight work areas. It comes equipped with either Inner Core cable or Integral Wound cable. Recommend 5/8" (16 mm) cable for 3" (75 mm) to 6" (150 mm) drain lines up to 200' (61 m).
- Cable Control System – causes the drum to stop spinning when the blade becomes lodged in a blockage, limits potential for cable to flip-over in the drum and helps indicate to operator when blockages are encountered.
- Direct Drive Design – 4/10 HP universal motor and gearbox bear down as torque builds. Motor tone lets operator know when blockage is encountered. Drum requires no adjustments to stay aligned and tight on drive shaft.
- Easy Maintenance Construction – Separate drum and machine in seconds. Inner drum and guide tube remove easily to maintain or replace cable.
- Designed Durable and Stable – Low center of gravity frame design and custom kickstand keep machine firmly anchored during operation. Rugged, corrosion-resistant polyethylene drum is rust and dent proof. Double tubular frame is lightweight and designed for extra strength.
- AUTOFEED® Control and Standard Accessories – Powerful feed mechanism is built to last and is easily maintained. AUTOFEED control, toolbox and selection of cutters included in all models.

SPECIFICATIONS

- Line Capacity – 3" - 6" (75-150 mm) Lines, up to 200' (61 m)
- Drum Capacity – 100' (30.5 m) of 5/8" (16 mm) cable
- Weight (Machine & 100' (30.5 m) of Cable) – 180 lbs. (81.6 kg)
- Size – Length 29 1/2" (75 cm), Height 43 1/2" (110 cm) (max.), Width 18 3/4", (47 cm)

MOTOR

- Type – 115V/60 Hz, 5.6 Amp, Reversible, Universal AC Motor
- Rating – 4/10 HP, 285 RPM













Machine Options

Catalog No.	Model No.	Description	Weight	
			lb	kg
93557	K-6200 with C-24 HD Cable	Machine, Standard Accessories and 5/8" x 100' (16 mm x 30.5 m) HD Solid Core Cable	180	81.8
95732	K-6200 with C-24	Machine, Standard Accessories and 5/8" x 100' (16 mm x 30.5 m) Inner Core Cable		
95737	K-6200	Machine with 5/8" (16 mm) Pigtail & Standard Accessories	98	44.5















Standard Equipment

Catalog No.	Description	93557	95732	95737
		K-6200 w/C24 HD Cable	K-6200 w/C-24	K-6200
37643	5/8" (16 mm) x 100' HD Cable (30.5 m)	●		
43647	5/8" (16 mm) x 100' IC Cable (30.5 m)		●	
68623	Soft Sided Tool Bag	●	●	●
70032	RIDGID PVC Drain Cleaning Gloves	●	●	●
92495	Spade Cutter, 1 3/4" (45 mm)	●	●	●
92510	Double Cutter, 2" (50 mm)	●	●	●
92520	Double Cutter, 3" (75 mm)	●	●	●
92525	Double Cutter, 4" (110 mm)	●	●	●
92555	5/8" (16 mm) x 2' (50 mm) Leader	●	●	●

Cables and Leaders

	Catalog No.	Model No.	Description	Weight		
				lb	kg	
5/8" - 16 mm		37628	C-25 HD	25' HD Cable (7.6 m)	24	10.9
		37633	C-26 HD	50' HD Cable (15.2 m)	43	19.5
		37638	C-27 HD	75' HD Cable (30.5 m)	63	28.6
		37643	C-24 HD	100 HD Cable (30.5 m)	84	38.1
		44122		5/8" (16 mm) Pigtail, 4 1/2' (1.4 m) Long	2 1/2	1.1
		58192	C-24HC	5/8" (16 mm) x 100' HC Cable (30.5 m)	70 1/2	32.1
		43647	C-24	5/8" (16 mm) x 100' IC Cable (30.5m)	84	38.1
		92460	C-25	5/8" (16 mm) x 25' IC Cable (7.6 m)	24	10.9
		92465	C-26	5/8" (16 mm) x 50' IC Cable (15.2 m)	43	19.5
		92470	C-27	5/8" (16 mm) x 75' IC Cable (22.9 m)	63	28.6
		92555	T-458	5/8" (16 mm) x 2' (50 mm) Leader	2	0.8
		32737	C-27HC	5/8" (16 mm) x 75' HC Cable (23 m)	52 3/4	23.9

Tools and Replacement Blades – Fit 5/8" (16 mm) and 3/4" (20 mm) Cables

	Catalog No.	Model No.	Description	Replac. Blade(s)	Replac. Holder
	51762R	T-409	H-D Bulb Auger, 1 3/4" (45 mm)	-	-
	92485	T-403	P-Trap Cutter, 3" (75 mm)	92835	92900
	92490	T-404	P-Trap Cutter, 3 1/2" (87 mm)	92840	92900
	92495	T-406	Spade Cutter, 1 3/4" (45 mm)	92850	92915
	92500	T-407	Retrieving Auger 2 9/16" (65 mm)	-	-
	92505	T-408	Sawtooth Cutter, 3" (75 mm)	92890	92915
	92510	T-411	Double Cutter, 2" (50 mm)	92815	92905
	92515	T-412	Double Cutter, 2 1/2" (65 mm)	92820	92905
	92520	T-413	Double Cutter, 3" (75 mm)	92825	92910
	92525	T-414	Double Cutter, 4" (110 mm)	92830	92910
	92530	T-416	Double Cutter, 6" (150 mm)	92855	92910
	92535	T-432	3-Blade Cutter 2" (50 mm)	92860	92895
	92545	T-434	3-Blade Cutter 4" (110 mm)	92870	92895
	92550	T-436	3-Blade Cutter 6" (150 mm)	92875	92895
	59230	A-13	3/8" Cable Pin Key	-	-

Accessories

Catalog No.	Description
92540	3-Blade Cutter 3" (75 mm)
49032	Front Guide Hose Assembly
68623	Soft Sided Tool Bag
70032	RIDGID PVC Drain Cleaning Gloves
91047	5/8" IW Cable Repair Coupling
95792	Swivel Loading Wheel Assembly
95797	Lifting Hook - K-6200
95802	K-6200 Drum Assy. w/5/8" Pigtail
95807	K-3800 Drum Assy. w/6200 Adapters
95812	AUTOFEED® Assembly
95822	K-3800 to K-6200 Adapter Kit Only

Drum Machines



K-750 DRUM MACHINE

- 3" to 8" (75 to 200 mm) Drain/Sewer Lines.
- Recommend 5/8" (16 mm) cable for 3" to 6" (75 to 150 mm) drain lines up to 150' (48 m).
- Recommend 3/4" (20 mm) cable for 4" to 8" (100 to 200 mm) drain lines up to 200' (62 m).
- Powerful, self-contained machine ideal for lateral lines. Easy to transport, minimal set-up – attach a tool and go.
- AUTOFEED® control advances and retrieves cable with a push of a lever, up to 20' (6 m) per minute.
- Versatile AUTOFEED control adjusts for either 5/8" (16 mm) or 3/4" (20 mm) cable with a twist of a screwdriver.
- Tough, corrosion-resistant cable drum withstands harsh treatment and abuse. It will not dent or corrode and cleans easily.
- Drum holds 100' (30.5 m) of 3/4" (20 mm) or 125' (35 m) of 5/8" (16 mm) cable and is designed for quick, easy removal.
- Balanced design gives the machine a lightweight "feel." Transport wheels ease loading into service truck/van.
- Equipped with 1/2 HP induction motor that spins cable at 200 RPM.
- Includes RIDGID PVC drain cleaning gloves and operators manual.

Machine Options

Catalog No.	Model No.	Description	Voltage		Weight	
			V		lb	kg
41977	K-750	Machine with Gloves and AUTOFEED - 3/4" (20 mm) Pigtail	120V, 50/60 Hz		114	51.9
51402		Machine with Gloves and AUTOFEED - 5/8" (16 mm) Pigtail			113	51.3
42002	K-750 with C-75	Machine with One Pair of Gloves, AUTOFEED, Standard 3/4" (20 mm) Tool Set, and: C-75, 75' (23 mm) x 3/4" (20 mm) Cable	120V, 50/60 Hz		206	93.6
42007	K-750	Machine with One Pair of Gloves, w/C-100 AUTOFEED, Standard 3/4" (20 mm) Tool Set, and: C-100, 100' (30.5 mm) x 3/4" (20 mm) Cable	120V, 50/60 Hz		234	106.3
42012	K-750 with C-27	Machine with One Pair of Gloves, AUTOFEED, Standard 5/8" (16 mm) Tool Set, and: C-27, 75' (23 mm) x 5/8" (16 mm) Cable	120V, 50/60 Hz		182	82.7
47047	K-750 with C-24	Machine with One Pair of Gloves, AUTOFEED, Standard 5/8" (16 mm) Tool Set, and: C-24, 100' (30.5 mm) x 5/8" (16 mm) Cable	120V, 50/60 Hz			
44202	K-750	Machine with Gloves and AUTOFEED - 3/4" (20 mm) Pigtail	220 - 240V, 50/60 Hz		114	51.9
51407		Machine with Gloves and AUTOFEED - 5/8" (16 mm) Pigtail			113	51.3
44212		Machine with One Pair of Gloves, w/C-100 AUTOFEED, Standard 3/4" (20 mm) Tool Set, and: C-100, 100' (30.5 mm) x 3/4" (20 mm) Cable	220 - 240V, 50/60 Hz	234	106.3	
44217	K-750 with C-27	Machine with One Pair of Gloves, AUTOFEED, Standard 5/8" (16 mm) Tool Set, and: C-27, 75' (23 mm) x 5/8" (16 mm) Cable	220 - 240V, 50/60 Hz		182	82.7





41977



Standard Equipment

Catalog No.	Description	41977 K-750	51402 K-750	42002 K-750 w/C-75	42007 K-750	42012 K-750 w/C-27	47047 K-750 w/C-24	44202 K-750	51407 K-750	44212 K-750	44217 K-750 w/C-27
41937	RIDGID Leather Drain Cleaning Gloves	•	•	•	•	•	•	•	•	•	•
68623	Soft Sided Tool Bag	•	•	•	•	•	•	•	•	•	•
41212	3/4" (20 mm) x 75' IC Cable (22.9m)			•							
92495	Spade Cutter, 1 3/4" (45 mm)			•	•	•	•			•	•
92500	Retrieving Auger 2 3/8" (65 mm)			•	•	•	•			•	•
92510	Double Cutter, 2" (50 mm)			•	•	•	•			•	•
92520	Double Cutter, 3" (75 mm)			•	•	•	•			•	•
92525	Double Cutter, 4" (110 mm)			•	•					•	
41697	3/4" (20 mm) x 100' IC Cable (30.5m)				•					•	
92470	5/8" (16 mm) x 75' IC Cable (22.9m)					•					•
92485	P-Trap Cutter, 3" (75 mm)					•	•				•
43647	5/8" (16 mm) x 100' IC Cable (30.5m)						•				



Inner Core (IC) Cables

	Catalog No.	Model No.	Description	Weight	
				lb	kg
	92460	C-25	5/8" (16 mm) x 25' IC Cable (7.6 m)	24	10.9
	92465	C-26	5/8" (16 mm) x 50' IC Cable (15.2 m)	43	19.5
	92470	C-27	5/8" (16 mm) x 75' IC Cable (22.9 m)	63	28.6
	43647	C-24	5/8" (16 mm) x 100' IC Cable (30.5 m)	84	38.1
	37643	C-24HD	5/8" (16 mm) x 100' Heavy Duty Cable (30.5 m)	85	38.6
	92475	C-28	3/4" (20 mm) x 25' IC Cable (7.6 m)	30	13.9
	92480	C-29	3/4" (20 mm) x 50' IC Cable (15.2 m)	60	27.2
	41212	C-75	3/4" (20 mm) x 75' IC Cable (22.9 m)	93	42.5
	41697	C-100	3/4" (20 mm) x 100' IC Cable (30.5 m)	122	55.3

Hollow Core Cables

	Catalog No.	Model No.	Description	Weight	
				lb	kg
	32737	C-27HC	5/8" (16 mm) x 75' HC Cable (23 m)	52 3/4	23.9
	58192	C-24HC	5/8" (16 mm) x 100' HC Cable (30.5 m)	70 1/2	32.1
	47427	C-75HC	3/4" (20 mm) x 75' HC Cable (23 m)	75	34.0
	47432	C-100HC	3/4" (20 mm) x 100' HC Cable (30.5 m)	100	45.5



Leaders and Pig Tails

	Catalog No.	Model No.	Description	Weight	
				lb	kg
	92555	T-458	5/8" (16 mm) x 2' (50 mm) Leader	2	0.9
	92560	T-468	3/4" (20 mm) x 2' (50 mm) Leader	2 3/4	1.3
	44122	-	5/8" (16 mm) Pigtail, 4 1/2' (1.4 m) Long	2 1/2	1.1
	44117	-	3/4" Pigtail Assembly	3 1/2	1.6

Accessories

	Catalog No.	Model No.	Description	Weight	
				lb	kg
	41982	A-7534	Drum Assembly with 3/4" (20 mm) Pigtail	37 1/2	17.0
	43637	A-7558	Drum Assembly with 5/8" (16 mm) Pigtail	33	15.0
	43642	A-75	AUTOFEED Assembly	8	3.5
	41937	-	RIDGID Leather Drain Cleaning Gloves	1/2	0.2
	41992	A-75PF	C-100IC Kit with Tools, 3/4" (20 mm) x 100' (30.5 m)	8	3.5
	49032	-	Front Guide Hose Assembly	3	1.3
	68623	-	Soft Sided Tool Bag	1.6	0.7
	70032	-	RIDGID PVC Drain Cleaning Gloves	1/2	0.2
	46015	-	Key, Hex 5/32	-	-

Repair Fittings

	Catalog No.	Model No.	Description	Weight	
				lb	kg
	31487	A-7570	5/8" (16 mm) Repair Splicer	1 1/2	43.0
	31492	A-7571	3/4" (20 mm) Repair Splicer	2	57.0
	92805	A-6582	5/8" (16 mm) Male Coupling	1	28.0
	92810	A-6583	5/8" (16 mm) Female Coupling	2	57.0
	92880	B-6840	3/4" (20 mm) Male Coupling	1	28.0
	92885	B-6841	3/4" (20 mm) Female Coupling	2	57.0

Tools and Replacement Blades – Fit 5/8" (16 mm) and 3/4" (20 mm) Cables

	Catalog No.	Model No.	Description	Replac. Blade(s)	Replac. Holder
	92485	T-403	P-Trap Cutter, 3" (75 mm)	92835	92900
	92490	T-404	P-Trap Cutter, 3 1/2" (87 mm)	92840	92900
	92495	T-406	Spade Cutter, 1 3/4" (45 mm)	92850	92915
	92500	T-407	Retrieving Auger, 2 1/2" (65 mm)	-	-
	92505	T-408	Sawtooth Cutter, 3" (75 mm)	92890	92915
	51762R	T-409	H-D Bulb Auger, 1 3/4" (45 mm)	-	-
	92510	T-411	Double Cutter, 2" (50 mm)	92815	92905
	92515	T-412	Double Cutter, 2 1/2" (65 mm)	92820	92905
	92520	T-413	Double Cutter, 3" (75 mm)	92825	92910
	92525	T-414	Double Cutter, 4" (110 mm)	92830	92910
	92530	T-416	Double Cutter, 6" (150 mm)	92855	92910
	92535	T-432	3-Blade Cutter, 2" (50 mm)	92860	92895
	92540	T-433	3-Blade Cutter, 3" (75 mm)	92865	92985
	92545	T-434	3-Blade Cutter, 4" (110 mm)	92870	92895
	92550	T-436	3-Blade Cutter, 6" (150 mm)	92875	92895

*STANDARD 3/4" (20 MM) TOOL SET INCLUDES

- T-406 Spade Cutter - 92495
- T-407 Retrieving Auger - 92500
- T-411 2" (50 mm) Cutter - 92510
- T-413 3" (75 mm) Cutter - 92520
- T-414 4" (110 mm) Cutter - 92525
- Hex Key - 46015

*STANDARD 5/8" (16 MM) TOOL SET INCLUDES

- T-403 3" (75 mm) P-Trap Cutter - 92485
- T-407 Retrieving Auger - 92500
- T-406 Spade Cutter - 92495
- T-411 2" (50 mm) Cutter - 92510
- T-413 3" (75 mm) Cutter - 92520
- Hex Key - 46015

*Sold Separately

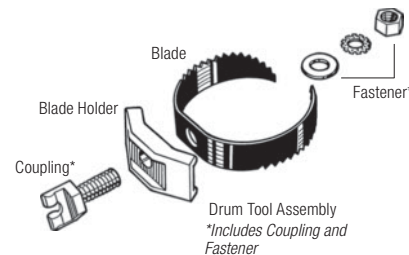

Drum Machines



59562

K-7500 DRUM MACHINE

- 3" to 10" (75-250 mm) Lines.
- Recommend 5/8" (16 mm) cable for 3" (75 mm) to 6" (150 mm) drain lines up to 250' (76 m).
- Recommend 3/4" (20 mm) cable for 4" (110 mm) to 10" (250 mm) drain lines up to 250' (76 m).
- Features performance, durability and maneuverability demanded by professional users. Ideal for tough jobs, such as roots.
- Powerful, yet quiet, 4/10 HP universal motor and gearbox spins cable at 200 RPM.
- Audible and visual signals for the operator.
- Main and inner drums won't rust, split or dent – ever. Cleans easily for professional appearance. Main drum holds up to 100' (30.5 m) of 3/4" (20 mm) cable, or 125' (38 m) of 5/8" (16 mm) cable.
- Powerful AUTOFEED® mechanism has grease fittings and an open design for easy maintenance. It advances and retrieves cable up to 22' (6.7 m) per minute.
- Two position stair climber eases transport and loading – to eliminate extra cost for loading wheels.
- Narrow profile lets the machine to fit through bathroom doors.
- Handles adjust to desired height to ensure balanced transport.
- Includes RIDGID PVC drain cleaning gloves and operator's manual.

Machine Options

Catalog No.	Model No.	Description	Voltage		Weight	
			V	lb	kg	
59562	K-7500	Machine with 3/4" (20 mm) Pigtail and Standard Accessories	110 - 115V, 50/60 Hz	150	86.2	
60052	K-7500 C-100	Machine, Standard Accessories, and 3/4" x 100' (20 mm x 30.5 m) Inner Core Cable.	110 - 115V, 50/60 Hz	272	123.7	
60062R	K-7500 w/C-75	Machine, Standard Accessories, and 3/4" x 75' (20 mm 22.9 m) Inner Core Cable.	110 - 115V, 50/60 Hz	244	110.9	
61102	K-7500	Machine with 5/8" (16 mm) Pigtail and Standard Accessories	110 - 115V, 50/60 Hz	149	67.8	
61522		Machine with 5/8" (16 mm) Pigtail and Standard Accessories	220 - 240V, 50/60 Hz			
61542		Machine with 3/4" (20 mm) Pigtail and Standard Accessories	220 - 240V, 50/60 Hz	150	86.2	

Standard Equipment

Catalog No.	Description	59562 K-7500	60052 K-7500 C-100	60062R K-7500 w/C-75	61102 K-7500	61522 K-7500	61542 K-7500
68623	Soft Sided Tool Bag	•	•	•	•	•	•
69250	3/16" Hex Wrench	•	•	•	•	•	•
70032	RIDGID PVC Drain Cleaning Gloves	•	•	•	•	•	•
92485	P-Trap Cutter, 3" (75 mm)	•	•	•	•	•	•
92495	Spade Cutter, 1 3/4" (45 mm)	•	•	•	•	•	•
92500	Retrieving Auger 2 9/16" (65 mm)	•	•	•	•	•	•
92505	Sawtooth Cutter, 3" (75 mm)	•	•	•	•	•	•
92510	Double Cutter, 2" (50 mm)	•	•	•	•	•	•
92520	Double Cutter, 3" (75 mm)	•	•	•	•	•	•
92560	3/4" (20 mm) x 2' (50 mm) Leader	•	•	•	•	•	•
92830	4" Double Cutter (Blade Only)	•	•	•	•	•	•
92855	6" Double Cutter (Blade Only)	•	•	•	•	•	•
41697	3/4" (20 mm) x 100' IC Cable (30.5 m)		•				
41212	3/4" (20 mm) x 75' IC Cable (22.9m)			•			

Cable Control & Performance – When Tool Engages Tough Obstructions

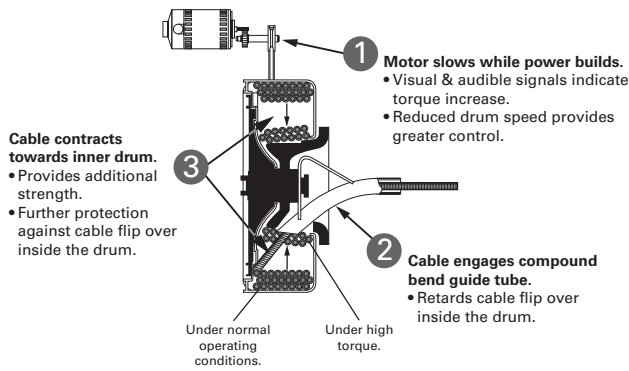

Visit RIDGID.com for the full instruction manual.

Accessories

	Catalog No.	Model No.	Description	Weight	
				lb	kg
	41937	-	RIDGID Leather Drain Cleaning Gloves	1/2	0.2
	41992	A-75PF	C-100IC Kit with Tools, 3/4" (20 mm) x 100' (30.5 m)	8	3.5
	49032	-	Front Guide Hose Assembly	3	1.3
	68623	-	Soft Sided Tool Bag	1.6	0.7
	60032	A-75PF	AUTOFEED® Assembly	10	4.5
	60037R	-	AUTOFEED® Spacers (4)		
	60042	A-7534D	Drum Assembly w/3/4" (20 mm) Pigtail	31	14.0
	60047R	A-75DR	Drum Only	20	9.0
	61107	A-7558D	Drum Assembly w/5/8" (16 mm) Pigtail	30	13.6
	70032	-	RIDGID PVC Drain Cleaning Gloves	1/2	0.2
	31487	A-7570	5/8" (16 mm) Repair Splicer	3/32	0.0
	31492	A-7571	3/4" (20 mm) Repair Splicer	1/8	0.1
	92805	A-6582	5/8" (16 mm) Male Coupling	1/16	0.0
	92810	A-6583	5/8" (16 mm) Female Coupling	1/8	0.1
	92880	B-6840	3/4" (20 mm) Male Coupling	1/16	0.0
	92885	B-6841	3/4" (20 mm) Female Coupling	1/8	0.1

Inner Core (IC) Cables

	Catalog No.	Model No.	Description	Weight	
				lb	kg
	92460	C-25	5/8" (16 mm) x 25' IC Cable (7.6 m)	24	10.9
	92465	C-26	5/8" (16 mm) x 50' IC Cable (15.2 m)	43	19.5
	92470	C-27	5/8" (16 mm) x 75' IC Cable (22.9 m)	63	28.6
	43647	C-24	3/4" (20 mm) x 100' IC Cable (30.5 m)	84	38.1
	92475	C-28	3/4" (20 mm) x 25' IC Cable (7.6 m)	30	13.9
	92480	C-29	3/4" (20 mm) x 50' IC Cable (15.2 m)	60	27.2
	41212	C-75	3/4" (20 mm) x 75' IC Cable (22.9 m)	93	42.5
	41697	C-100	3/4" (20 mm) x 100' IC Cable (30.5 m)	122	55.3

Hollow Core Cables

	Catalog No.	Model No.	Description	Weight	
				lb	kg
	32737	C-27HC	5/8" (16 mm) x 75' HC Cable (23 m)	52 3/4	23.9
	58192	C-24HC	5/8" (16 mm) x 100' HC Cable (30.5 m)	70 1/2	32.1
	47427	C-75HC	3/4" (20 mm) x 75' HC Cable (23 m)	75	34.0
	47432	C-100HC	3/4" (20 mm) x 100' HC Cable (30.5 m)	100	45.5

Leaders and Pig Tails

	Catalog No.	Model No.	Description	Weight	
				lb	kg
	92555	T-458	5/8" (16 mm) x 2' (50 mm) Leader	2	0.9
	92560	T-468	3/4" (20 mm) x 2' (50 mm) Leader	2 3/4	1.3
	44122	-	5/8" (16 mm) Pigtail, 4 1/2' (1.4 m) Long	2 1/2	1.1
	44117	-	3/4" Pigtail Assembly	3 1/2	1.6

Tools and Replacement Blades – Fit 5/8" (16 mm) and 3/4" (20 mm) Cables

	Catalog No.	Model No.	Description	Replac. Blade(s)	Replac. Holder
	51762R	T-409	H-D Bulb Auger, 1 3/4" (45 mm)	-	-
	92485	T-403	P-Trap Cutter, 3" (75 mm)	92835	92900
	92490	T-404	P-Trap Cutter, 3 1/2" (87 mm)	92840	92900
	92495	T-406	Spade Cutter, 1 3/4" (45 mm)	92850	92915
	92500	T-407	Retrieving Auger 2 9/16" (65 mm)	-	-
	92505	T-408	Sawtooth Cutter, 3" (75 mm)	92890	92915
	92510	T-411	Double Cutter, 2" (50 mm)	92815	92905
	92515	T-412	Double Cutter, 2 1/2" (65 mm)	92820	92905
	92520	T-413	Double Cutter, 3" (75 mm)	92825	92910
	92525	T-414	Double Cutter, 4" (110 mm)	92830	92910
	92530	T-416	Double Cutter, 6" (150 mm)	92855	92910
	92535	T-432	3-Blade Cutter 2" (50 mm)	92860	92895
	92540	T-433	3-Blade Cutter 3" (75 mm)	92865	92895
	92545	T-434	3-Blade Cutter 4" (110 mm)	92870	92895
	92550	T-436	3-Blade Cutter 6" (150 mm)	92875	92895

C-24, C-25, C-26, C-27, C-28, C-29, C-75, C-100, C-27HC, C-24HC, C-75HC and C-100HC.

Drum Machines



K-750R DRUM MACHINE

- 3" to 6" (75 mm to 150 mm) Drain Lines.
- The K-750R is a self-contained drain cleaner ideal for lateral drain lines from 3" to 6" (75 mm to 150 mm). Easy-to-transport, narrow design for small entry ways and minimal setup make this machine ideal for tough mainline work. Comes equipped with a large blade assortment to handle numerous applications. Clears roots, debris and foreign objects out of main lines, storm drains, house laterals and leach lines.
- Clear access to drum allows immediate view of cable for inspection plus easier and faster cleaning of drum and cable.
- Cable Control System – causes the drum to stop spinning when the blade becomes lodged in a blockage, limits potential for cable to flip-over in the drum and helps indicate to operator when blockages are encountered.
- New integral-wound, solid core cable is tough and kink resistant. 5/8" x 100' (16 mm x 30.5 m).
- Dual kickstands.
- Torque limiting feature.
- Lean, balanced design for easy one-man transport and operation.

SPECIFICATIONS

- Motor – 1/2 HP, 120V, 50/60Hz reversible induction motor, 200 RPM
- Control – Air activated foot switch

Catalog No.	Model No.	Description	Weight	
			lb	kg
83557	K-750R	5/8" (16 mm) Open Cage Drum Machine with 5/8" x 100' (16 mm x 30.5 m) IW Solid Core Cable; 2", 3", 4" "C" Cutters; P-Trap Cutter; Spade Blade; Tool Box; Gloves.	194	98.0



Standard Equipment

Catalog No.	Description	83557 K-750R
37753	5/8" x 100' Heavy Duty Inner Core Cable; Rental Tool; Special Coupling with Mounting Bolt	●
68623	Soft Sided Tool Bag	●
92485	P-Trap Cutter, 3" (75 mm)	●
92495	Spade Cutter, 1 3/4" (45 mm)	●
92510	Double Cutter, 2" (50 mm)	●
92520	Double Cutter, 3" (75 mm)	●
92525	Double Cutter, 4" (110 mm)	●





83557















Inner Core (IC) Cables

	Catalog No.	Model No.	Description	Weight	
				lb	kg
	92460	C-25	5/8" (16 mm) x 25' IC Cable (7.6m)	24	10.9
	92465	C-26	5/8" (16 mm) x 50' IC Cable (15.2m)	43	19.5
	92470	C-27	5/8" (16 mm) x 75' IC Cable (22.9m)	63	28.6
	43647	C-24	5/8" (16 mm) x 100' IC Cable (30.5m)	84	38.1
	92475	C-28	3/4" (20 mm) x 25' IC Cable (7.6m)	30	13.9
	92480	C-29	3/4" (20 mm) x 50' IC Cable (15.2m)	60	27.2
	41212	C-75	3/4" (20 mm) x 75' IC Cable (22.9m)	93	42.5
	41697	C-100	3/4" (20 mm) x 100' IC Cable (30.5m)	122	55.3



Hollow Core Cables

	Catalog No.	Model No.	Description	Weight	
				lb	kg
	32737	C-27HC	5/8" (16 mm) x 75' HC Cable (23 m)	52 3/4	23.9
	58192	C-24HC	5/8" (16 mm) x 100' HC Cable (30.5 m)	70 1/2	32.1
	47427	C-75HC	3/4" (20 mm) x 75' HC Cable (23 m)	75	34.0
	47432	C-100HC	3/4" (20 mm) x 100' HC Cable (30.5 m)	100	45.5

Tools and Replacement Blades – Fit 5/8" (16 mm) and 3/4" (20 mm) Cables

	Catalog No.	Model No.	Description	Replac. Blade(s)	Replac. Holder
	51762R	T-409	H-D Bulb Auger, 1 3/4" (45 mm)	-	-
	92485	T-403	P-Trap Cutter, 3" (75 mm)	92835	92900
	92490	T-404	P-Trap Cutter, 3 1/2" (87 mm)	92840	92900
	92495	T-406	Spade Cutter, 1 3/4" (45 mm)	92850	92915
	92500	T-407	Retrieving Auger 2 9/16" (65 mm)	-	-
	92505	T-408	Sawtooth Cutter, 3" (75 mm)	92890	92915
	92510	T-411	Double Cutter, 2" (50 mm)	92815	92905
	92515	T-412	Double Cutter, 2 1/2" (65 mm)	92820	92905
	92520	T-413	Double Cutter, 3" (75 mm)	92825	92910
	92525	T-414	Double Cutter, 4" (110 mm)	92830	92910
	92530	T-416	Double Cutter, 6" (150 mm)	92855	92910
	92535	T-432	3-Blade Cutter 2" (50 mm)	92860	92895
	92540	T-433	3-Blade Cutter 3" (75 mm)	92865	92895
	92545	T-434	3-Blade Cutter 4" (110 mm)	92870	92895
	92550	T-436	3-Blade Cutter 6" (150 mm)	92875	92895

Leaders and Pig Tails

	Catalog No.	Model No.	Description	Weight	
				lb	kg
	92555	T-458	5/8" (16 mm) x 2' (50 mm) Leader	2	0.9
	92560	T-468	3/4" (20 mm) x 2' (50 mm) Leader	2 3/4	1.3
	44122	-	5/8" (16 mm) Pigtail, 4 1/2' (1.4 m) Long	2 1/2	1.1
	44117	-	3/4" Pigtail Assembly	3 1/2	1.6

Accessories

Catalog No.	Model No.	Description	Weight	
			lb	kg
41982	A-7534	Drum Assembly with 3/4" (20 mm) Pigtail	37 1/2	17.0
43637	A-7558	Drum Assembly with 5/8" (16 mm) Pigtail	33	15.0
43642	A-75	AUTOFEED Assembly	8	3.5
41937	-	RIDGID Leather Drain Cleaning Gloves	1/2	0.2
41992	A-75PF	C-100IC Kit with Tools, 3/4" (20 mm) x 100' (30.5 m)	8	3.5
49032	-	Front Guide Hose Assembly	3	1.3
68623	-	Soft Sided Tool Bag	1.6	0.7
70032	-	RIDGID PVC Drain Cleaning Gloves	1/2	0.2

Repair Fittings

	Catalog No.	Model No.	Description	Weight	
				lb	kg
	31487	A-7570	5/8" (16 mm) Repair Splicer	1 1/2	43.0
	31492	A-7571	3/4" (20 mm) Repair Splicer	2	57.0
	92805	A-6582	5/8" (16 mm) Male Coupling	1	28.0
	92810	A-6583	5/8" (16 mm) Female Coupling	2	57.0
	92880	B-6840	3/4" (20 mm) Male Coupling	1	28.0
	92885	B-6841	3/4" (20 mm) Female Coupling	2	57.0

Sectional Machines

APPLICATION CHART



	Sink Lines		Floor/Secondary Drains		Laterals & Main Lines	
Line Size	3/4" - 4" (19 - 102 mm)	1 1/4" - 4" (32 - 102 mm)	2" - 8" (51 - 203 mm)	2" - 8" (51 - 203 mm)	2" - 10" (51 - 254 mm)	2" - 10" (51 - 254 mm)
Speed	400 RPM	600 RPM	700 RPM	710 RPM	600 RPM	600 RPM
Horsepower	1/8 HP	1/8 HP	3/8 HP	3/8 HP	1 HP	6 HP Gas
Weight	37 lb (17 kg)	41 lb (19 kg)	55 lb (25 kg)	135 lb (61 kg)	141 lb (64 kg)	190 lb (86 kg)

CABLES FOR SECTIONAL MACHINES

	K-50	K-60SP	K-5208, K-1500, K-1500SP & K-1500G
Cable Diameter	5/8" (16 mm)	5/8", 7/8" (16 mm, 22 mm)	7/8", 1 1/4" (22 mm, 32 mm)
Available Lengths	7 1/2', 10' (2 m, 3 m)	7 1/2', 10', 15' (2 m, 3 m, 4.6 m)	15' (4.6 m)
Cable Type	Tight Wound, All-Purpose Wound, Heavy-Duty Wound	Tight Wound, All-Purpose Wound, Heavy-Duty Wound, Plastic Core	All-Purpose Wound, Plastic Core, Extra Heavy-Duty Wound, Heavy-Duty Wound, Extra Flexibility

Tight Wound – Cable provides good rigidity in a hollow core cable.

All Purpose Wound – Provides excellent flexibility, yet rigid enough for fast tough cleaning.

Heavy-Duty Wound – Open wind especially good for long runs.

Extra Heavy-Duty Wound – Designed for 4" to 10" (102 mm to 250 mm) lines.

Plastic Core – Standard all-purpose wind with plastic core to help prevent buildup inside cable.

Extra Flexibility – Recommended for 3" to 6" (76 to 152 mm) lines and ideal for 4" (102 mm) traps.

Sectional Machines



58920



58960

K-50 SECTIONAL MACHINE

- 3/4" to 4" (20 mm to 110 mm) drain lines.
- Compact, versatile professional's machine. Capable of running three different size cables: 5/16" (8 mm), 3/8" (10 mm) and 5/8" (16 mm). The perfect, all-around sink, shower and floor drain machine. Weighs less than 40 lbs (18 kg).
- Uses sections of 5/8" (16 mm) cable, cleans 1 1/4" to 4" (32 mm to 110 mm) lines up to 100 feet.
- C-8 best for 1 1/4" to 3" (32 mm to 75 mm) drains.
- C-9 best for 2" to 4" (50 mm to 110 mm) drains.
- Equipped with an A-17 drum adapter for runs up to 50' (15 m) of 5/16" (8 mm) cable or, 35' (11 m) of 3/8" (10 mm) continuous length cable.
- 5/16" (8 mm) best for 3/4" (20 mm) to 1 1/2" (40 mm) lines.
- 3/8" (10 mm) best for 1 1/4" (32 mm) to 2" (50 mm) lines.
- Unique, easy-to-use, instant-acting cable clutch maximizes operator control.
- Equipped with 1/6 HP motor that spins cable at 400 RPM.
- Includes A-1 RIDGID drain cleaning mitt and operator's manual.

Machine Options

Catalog No.	Model No.	Description	Voltage		Weight	
			V	lb	kg	
58920	K-50	Machine Only	120V, 60 Hz	37	16.8	
58960	K-50-4	Machine, with A-30 Cable Kit	120V, 60 Hz	61	27.7	
58980	K-50-6	Machine, with -17-A Adapter, A-30 Cable Kit	120V, 60 Hz	67	30.4	
59000	K-50-8	Machine, with A-17-A Adapter, A-17-B Adapter, A-30 Cable Kit	120V, 60 Hz	77	34.9	
52972	K-50-9	Machine, with A-40 Cable Kit	120V, 60 Hz	74	33.6	
76455	K-50	Machine Only	220 - 240V, 50/60 Hz	37	16.8	
76475	K-50-4	Machine, with A-30 Cable Kit	220 - 240V, 50/60 Hz	61	27.7	
76485	K-50-6	Machine, with -17-A Adapter, A-30 Cable Kit	220 - 240V, 50/60 Hz	67	30.4	
76495	K-50-8	Machine, with A-17-A Adapter, A-17-B Adapter, A-30 Cable Kit	220 - 240V, 50/60 Hz	77	34.9	

A-30 Cable Kit Includes:

- Six Sections C-8, 7 1/2' x 5/8" Cable (45 feet).
- A-10 Cable Carrier
- T-201 Straight Auger
- T-202 Bulb Auger
- T-205 "C" Cutter
- T-211 Spade Cutter
- A-13 Coupling Pin Key
- A-14-6 Rear Guide Hose
- A-1 Left-Hand RIDGID Drain Cleaning Mitt

Model K-50-8 includes:

- K-50 Machine
- A-17-A, Drum Adapter includes: 25' x 5/16", C-1 Bulb Auger Cable
- A-17-B, Drum Adapter includes: 35' x 3/8", C-5 Bulb Auger Cable
- A-1 RIDGID Drain Cleaning Mitt

DRAIN CLEANING

Cables

	Catalog No.	Model No.	Description	Weight	
				lb	kg
5/8" - 16 mm	62265	C-7	5/8" (16 mm) x 7 1/2' (2.3 m) Tight-Wind	4	1.8
		C-8	5/8" (16 mm) x 7 1/2' (2.3 m) All-Purpose Wind	3	1.4
	51317	C-9	5/8" (16 mm) x 10' (3.1 m) Heavy-Duty Wind	5	2.2
3/8" - 10 mm	62245	C-4	3/8" (10mm) x 25' (7.6 m) with Male Coupling	4 1/2	2.0
	62250	C-5	3/8" (10mm) x 35' (10.7 m) with Bulb Auger	8 1/4	3.8
	62260	C-6	3/8" (10 mm) x 35' (10.7 m) with Male Coupling		
5/8" - 8 mm	96037	C-6IC	3/8" (10mm) x 35' (10.7 m) Inner Core with Male Coupling	8 1/2	4.0
	62225	C-1	5/16" (8 mm) x 25' (7.6 m) with Bulb Auger	3 1/2	1.6
	56782	C-1IC	5/16" (8 mm) x 25' (7.6 m) Inner Core with Bulb Auger	4	1.8
	89400	C-21	5/16" (8 mm) x 50' (15.2 m) with Bulb Auger	7	3.2
	62235	C-2	5/16" (8 mm) x 25' (7.6 m) with Drop Head Auger	3 1/2	1.6
	56787	C-2IC	5/16" (8 mm) x 25' (7.6 m) Inner Core with Drop Head Auger	4	1.8
	89405	C-22	5/16" (8 mm) x 50' (15.2 m) with Drop Head Auger	7	3.2

Cable Kits

	Catalog No.	Model No.	Cable	Tools & Accessories	Weight	
					lb	kg
	59365	A-30	Six Sections: C-8, 5/8" x 7 1/2' (45', 13.7 m)	T-201 Straight Auger T-202 Bulb Auger T-205 "C" Cutter T-211 Spade Cutter A-13 Coupling Pin Key A-10 Cable Carrier A-14-6 Rear Guide Hose A-1 Left-Hand RIDGID Drain Cleaning Mitt	20	9.1
	52962	A-40	Six Sections: C-9, 5/8" x 10' (60', 18.3 m)	T-206 Funnel Auger T-215 4-Blade Cutter T-231 "C" Cutter A-13 Coupling Pin Key A-10 Cable Carrier A-14-10 Rear Guide Hose A-1 Left-Hand RIDGID Drain Cleaning Mitt	37	16.8
	59370	A-30TW	Six Sections: C-7, 5/8" x 7 1/2' (45', 13.7m) Tight-Wind	Same as A-30	30	13.6

Drum Adapters

	Catalog No.	Model No.	Description	Weight	
				lb	kg
	59250	A-17-A	Drum adapter With 25' (7.6 m) x 5/16" (8 mm) Cable w/Bulb Auger	8	3.6
	59255	A-17-B	Drum adapter With 35' (10.7 m) x 3/8" (10 mm) Cable w/Bulb Auger	13	5.9
	59265	A-17-C	Drum adapter With 35' x 3/8" Cable w/Male Coupling		
	92095	A-17-D	Drum adapter With 50' x 5/16" Cable w/Bulb Auger	12	5.4
	92100	A-17-E	Drum adapter With 25' x 5/16" Cable w/Drop Head		

Accessories

	Catalog No.	Model No.	Description	Weight	
				lb	kg
	59235	A-14-6	6' (1.8 m) Rear Guide Hose	5	2.3
	84325	A-14-10	10' (3 m) Rear Guide Hose	7	3.2
	59210	A-10	Cable Carrier Holds 90' (27 m) C-8, C-9	3 1/4	1.5
	59205	A-1	Left-Hand RIDGID Drain Cleaning Mitt		
	59295	A-2	Right-Hand RIDGID Drain Cleaning Mitt	1/2	0.2
	59230	A-13	3/8" Cable Pin Key		
	61718	-	Trident Sectional Cable Decoupler	3/4	0.3
	61708	-	Sectional Cable Carrier	33	15
	61713	-	Sectional Cable Drum	15	6.8
	59450	A-3179	A-3179 Clutch Jaw Assembly	1 1/2	0.7

Tools - Fits 3/8" Drum and 5/8" Sectional Cable

	Catalog No.	Model No.	Description	Replac. Blade(s)
	62990	T-201	Straight Auger, 5" (125 mm) Long	
	62067	T-201A	Straight Flex Auger	
	62995	T-202	Bulb Auger, 1 1/8" (29 mm) O.D.	
	63000	T-203	Bulb Auger 7/8" (22 mm) O.D.	
	54837	T-204	"C" Cutter 1" (25 mm)	54832
	63005	T-205	"C" Cutter, 1 3/8" (35 mm)	97835
	52812	T-230	H-D "C" Cutter, 2" (50 mm)	92815
	52817R	T-231	H-D "C" Cutter, 2 1/2" (65 mm)	92820
	52822	T-232	H-D "C" Cutter, 3" (80 mm)	92835
	63010	T-206	Funnel Auger, 3" (80 mm) Long	-
	63015	T-207	Spiral Cutter, 1 1/4" (32 mm)	97840
	63020	T-208	Spiral Cutter, 1 1/2" (40 mm)	97895
	63025	T-209	Spiral Cutter, 2" (50 mm)	97900
	63030	T-210	Spade Cutter, 1" (25 mm)	97905
	63035	T-211	Spade Cutter, 1 3/8" (35 mm)	97825
	63040	T-212	Spade Cutter, 1 3/4" (45 mm)	92850
	63045	T-213	4-Blade Cutter, 1" (25 mm)	97795
	63050	T-214	4-Blade Cutter, 1 3/8" (35 mm)	97910
	63055	T-215	4-Blade Cutter, 1 3/4" (45 mm)	97915
	63060	T-216	Chain Knocker, 2" (50 mm)	98000
	63065	T-217	Drop Head Auger, 4" (110 mm) Long	
	63280	T-218	Flue Brush, 3" (75 mm)	
	63070	T-219	Flue Brush, 2 1/2" (65 mm)	
	63080	T-220	Flue Brush, 2" (50 mm)	
	63220	T-221	Flue Brush, 1 1/2" (40 mm)	
	55457	T-225	Retrieving Auger	
	12128	T-240	Tool Set (5/8"- K-380): T-202 Bulb Auger, T-211 Spade Cutter, A-13 Pin Key	